

IN1606

IN1608 Series

Scaling Presentation Switchers



Safety Instructions

Safety Instructions • English

WARNING: This symbol, , when used on the product, is intended to alert the user of the presence of uninsulated dangerous voltage within the product's enclosure that may present a risk of electric shock.

ATTENTION: This symbol, , when used on the product, is intended to alert the user of important operating and maintenance (servicing) instructions in the literature provided with the equipment.

For information on safety guidelines, regulatory compliances, EMI/EMF compatibility, accessibility, and related topics, see the Extron Safety and Regulatory Compliance Guide, part number 68-290-01, on the Extron website, www.extron.com.

تعليمات السلامة • العربية

تحذير: هذا الرمز، , عند استخدامه على المنتج، مخصص لتنبيه المستخدم فيما يتعلق بوجود جهد كهربائي غير معزول على الغلاف الخارجي للمنتج وهو ما قد ينطوي على مخاطر حدوث صدمة كهربائية.

انتبه: هذا الرمز، , عند استخدامه على المنتج، مخصص لتنبيه المستخدم بتعليمات التشغيل والصيانة الهامة (الخدمة) في المواد التي يتم توفيرها مع المعدات.

للحصول على المزيد من المعلومات حول إرشادات السلامة، والتوافق التنظيمية، والتوافق الكهرومغناطيسي/المجال الكهرومغناطيسي، وإمكانية الوصول، والموضوعات ذات الصلة، يُرجى مراجعة دليل السلامة والتوافق التنظيمي الخاص بأكسترون، الجزء رقم 68-290-01، على موقع إكسترون، www.extron.com.

Sicherheitsanweisungen • Deutsch

WARUNG: Dieses Symbol , auf dem Produkt soll den Benutzer darauf aufmerksam machen, dass im Inneren des Gehäuses dieses Produktes gefährliche Spannungen herrschen, die nicht isoliert sind und die einen elektrischen Schlag verursachen können.

VORSICHT: Dieses Symbol , auf dem Produkt soll dem Benutzer in der im Lieferumfang enthaltenen Dokumentation besonders wichtige Hinweise zur Bedienung und Wartung (Instandhaltung) geben.

Weitere Informationen über die Sicherheitsrichtlinien, Produkthandhabung, EMI/EMF-Kompatibilität, Zugänglichkeit und verwandte Themen finden Sie in den Extron-Richtlinien für Sicherheit und Handhabung (Artikelnummer 68-290-01) auf der Extron-Website, www.extron.com.

Instrucciones de seguridad • Español

ADVERTENCIA: Este símbolo, , cuando se utiliza en el producto, avisa al usuario de la presencia de voltaje peligroso sin aislar dentro del producto, lo que puede representar un riesgo de descarga eléctrica.

ATENCIÓN: Este símbolo, , cuando se utiliza en el producto, avisa al usuario de la presencia de importantes instrucciones de uso y mantenimiento estas están incluidas en la documentación proporcionada con el equipo.

Para obtener información sobre directrices de seguridad, cumplimiento de normativas, compatibilidad electromagnética, accesibilidad y temas relacionados, consulte la Guía de cumplimiento de normativas y seguridad de Extron, referencia 68-290-01, en el sitio Web de Extron, www.extron.com.

Instructions de sécurité • Français

AVERTISSEMENT : Ce pictogramme, , lorsqu'il est utilisé sur le produit, signale à l'utilisateur la présence à l'intérieur du boîtier du produit d'une tension électrique dangereuse susceptible de provoquer un choc électrique.

ATTENTION : Ce pictogramme, , lorsqu'il est utilisé sur le produit, signale à l'utilisateur des instructions d'utilisation ou de maintenance importantes qui se trouvent dans la documentation fournie avec l'équipement.

Pour en savoir plus sur les règles de sécurité, la conformité à la réglementation, la compatibilité EMI/EMF, l'accessibilité, et autres sujets connexes, lisez les informations de sécurité et de conformité Extron, réf. 68-290-01, sur le site Extron, www.extron.com.

Istruzioni di sicurezza • Italiano

AVVERTENZA: Il simbolo, , se usato sul prodotto, serve ad avvertire l'utente della presenza di tensione non isolata pericolosa all'interno del contenitore del prodotto che può costituire un rischio di scosse elettriche.

ATTENZIONE: Il simbolo, , se usato sul prodotto, serve ad avvertire l'utente della presenza di importanti istruzioni di funzionamento e manutenzione nella documentazione fornita con l'apparecchio.

Per informazioni su parametri di sicurezza, conformità alle normative, compatibilità EMI/EMF, accessibilità e argomenti simili, fare riferimento alla Guida alla conformità normativa e di sicurezza di Extron, cod. articolo 68-290-01, sul sito web di Extron, www.extron.com.

Instrukcje bezpieczeństwa • Polska

OSTRZEŻENIE: Ten symbol, , gdy używany na produkcie, ma na celu poinformować użytkownika o obecności izolowanego i niebezpiecznego napięcia wewnątrz obudowy produktu, który może stanowić zagrożenie porażenia prądem elektrycznym.

UWAGI: Ten symbol, , gdy używany na produkcie, jest przeznaczony do ostrzeżenia użytkownika ważne operacyjne oraz instrukcje konserwacji (obsługi) w literaturze, wyposażone w sprzęt.

Informacji na temat wytycznych w sprawie bezpieczeństwa, regulacji wzajemnej zgodności, zgodność EMI/EMF, dostępności i Tematy pokrewne, zobacz Extron bezpieczeństwa i regulacyjnego zgodności przewodnik, część numer 68-290-01, na stronie internetowej Extron, www.extron.com.

Инструкция по технике безопасности • Русский

ПРЕДУПРЕЖДЕНИЕ: Данный символ, , если указан на продукте, предупреждает пользователя о наличии неизолированного опасного напряжения внутри корпуса продукта, которое может привести к поражению электрическим током.

ВНИМАНИЕ: Данный символ, , если указан на продукте, предупреждает пользователя о наличии важных инструкций по эксплуатации и обслуживанию в руководстве, прилагаемом к данному оборудованию.

Для получения информации о правилах техники безопасности, соблюдении нормативных требований, электромагнитной совместимости (ЭМП/ЭДС), возможности доступа и других вопросах см. руководство по безопасности и соблюдению нормативных требований Extron на сайте Extron: www.extron.com, номер по каталогу - 68-290-01.

安全说明 • 简体中文

警告 ⚠️ 产品上的这个标志意在警告用户, 该产品机壳内有暴露的危险电压, 有触电危险。

注意 ⚠️ 产品上的这个标志意在提示用户, 设备随附的用户手册中有重要的操作和维护(维修)说明。

关于我们产品的安全指南、遵循的规范、EMI/EMF 的兼容性、无障碍使用的特性等相关内容, 敬请访问 Extron 网站, www.extron.com, 参见 Extron 安全规范指南, 产品编号 68-290-01。

安全記事 • 繁體中文

警告 ⚠️ 若產品上使用此符號, 是為了提醒使用者, 產品機殼內存在未隔離的危險電壓, 可能會導致觸電之風險。

注意 ⚠️ 若產品上使用此符號, 是為了提醒使用者, 設備隨附的用戶手冊中有重要的操作和維護(維修)說明。

有關安全性指導方針、法規遵守、EMI/EMF 相容性、存取範圍和相關主題的詳細資訊, 請瀏覽 Extron 網站:www.extron.com 然後參閱《Extron 安全性與法規遵守手冊》, 準則編號 68-290-01。

安全上のご注意 • 日本語

警告: この記号 ⚠️ が製品上に表示されている場合は、筐体内に絶縁されていない高電圧が流れ、感電の危険があることを示しています。

注意: この記号 ⚠️ が製品上に表示されている場合は、本機の取扱説明書に記載されている重要な操作と保守(整備)の指示についてユーザーの注意を喚起するものです。

安全上のご注意、法規遵守、EMI/EMF適合性、その他の関連項目については、エクストロンのウェブサイト www.extron.com より「Extron Safety and Regulatory Compliance Guide」(P/N 68-290-01) をご覧ください。

안전 지침 • 한국어

경고: 이 기호 ⚠️가 제품에 사용될 경우, 제품의 인클로저 내에 있는 접지되지 않은 위험한 전류로 인해 사용자가 감전될 위험이 있음을 경고합니다.

주의: 이 기호 ⚠️가 제품에 사용될 경우, 장비와 함께 제공된 책자에 나와 있는 주요 운영 및 유지보수(정비) 지침을 경고합니다.

안전 가이드라인, 규제 준수, EMI/EMF 호환성, 접근성, 그리고 관련 항목에 대한 자세한 내용은 Extron 웹 사이트(www.extron.com)의 Extron 안전 및 규제 준수 안내서, 68-290-01 조항을 참조하십시오.

Copyright

© 2013-2022 Extron. All rights reserved. www.extron.com

Trademarks

All trademarks mentioned in this guide are the properties of their respective owners.

The following registered trademarks (®), registered service marks (SM), and trademarks (TM) are the property of RGB Systems, Inc. or Extron (see the current list of trademarks on the [Terms of Use](#) page at www.extron.com):

Registered Trademarks (®)
Extron, Cable Cubby, ControlScript, CrossPoint, DTP, eBUS, EDID Manager, EDID Minder, eLink, Flat Field, FlexOS, Glitch Free, Global Configurator, Global Scripter, GlobalViewer, Hideaway, HyperLane, IP Intercom, IP Link, Key Minder, LinkLicense, LockIt, MediaLink, MediaPort, NAV, NetPA, PlenumVault, PoleVault, PowerCage, PURE3, Quantum, ShareLink, Show Me, SoundField, SpeedMount, SpeedSwitch, StudioStation, System <i>INTEGRATOR</i> , TeamWork, TouchLink, V-Lock, VN-Matrix, VoiceLift, WallVault, WindoWall, XPA, XTP, XTP Systems, and ZipClip
Registered Service Mark (SM) : S3 Service Support Solutions
Trademarks (TM)
AAP, AFL (Accu-RATE Frame Lock), ADSP (Advanced Digital Sync Processing), AVEdge, CableCover, CDRS (Class D Ripple Suppression), Codec Connect, DDSP (Digital Display Sync Processing), DMI (Dynamic Motion Interpolation), Driver Configurator, DSP Configurator, DSVP (Digital Sync Validation Processing), EQIP, Everlast, FastBite, Flex55, FOX, FOXBOX, IP Intercom HelpDesk, MAAp, MicroDigital, Opti-Torque, PendantConnect, ProDSP, QS-FPC (QuickSwitch Front Panel Controller), Room Agent, Scope-Trigger, SIS, Simple Instruction Set, Skew-Free, SpeedNav, Triple-Action Switching, True4K, True8K, Vector™ 4K, WebShare, XTRA, and ZipCaddy

FCC Class A Notice

This equipment has been tested and found to comply with the limits for a Class A digital device, pursuant to part 15 of the FCC rules. The Class A limits provide reasonable protection against harmful interference when the equipment is operated in a commercial environment. This equipment generates, uses, and can radiate radio frequency energy and, if not installed and used in accordance with the instruction manual, may cause harmful interference to radio communications. Operation of this equipment in a residential area is likely to cause interference. This interference must be corrected at the expense of the user.

ATTENTION:

- The Twisted Pair Extension technology works with unshielded twisted pair (UTP) or shielded twisted pair (STP) cables; **but to ensure FCC Class A and CE compliance, STP cables and STP Connectors are required.**
- La technologie extension paires torsadées fonctionne avec les câbles paires torsadées blindées (UTP) ou non blindées (STP). Afin de s'assurer de la compatibilité entre FCC Classe A et CE, les câbles STP et les connecteurs STP sont nécessaires.

NOTES:

- This unit was tested with shielded I/O cables on the peripheral devices. Shielded cables must be used to ensure compliance with FCC emissions limits.
- For more information on safety guidelines, regulatory compliances, EMI/EMF compatibility, accessibility, and related topics, see the [Extron Safety and Regulatory Compliance Guide](#) on the Extron website.

VCCI-A Notice

この装置は、クラスA情報技術装置です。この装置を家庭環境で使用すると、電波妨害を引き起こすことがあります。その場合には使用者が適切な対策を講ずるよう要求されることがあります。

VCCI-A

70 Volt Model

CAUTION: For MA 70 models, touching uninsulated amplifier terminals or wiring may result in an unpleasant sensation.

ATTENTION : Pour les modèles MA 70, veuillez ne pas toucher le câblage ou les bornes non isolées de l'amplificateur pour éviter toute sensation désagréable.

Battery Notice

This product contains a battery. **Do not open the unit to replace the battery.** If the battery needs replacing, return the entire unit to Extron (for the correct address, see the Extron Warranty section on the last page of this guide).

CAUTION: Risk of explosion. Do not replace the battery with an incorrect type. Dispose of used batteries according to the instructions.

ATTENTION : Risque d'explosion. Ne pas remplacer la pile par le mauvais type de pile. Débarrassez-vous des piles usagées selon le mode d'emploi.

Conventions Used in this Guide

Notifications

The following notifications are used in this guide:

CAUTION: Risk of minor personal injury.

ATTENTION : Risque de blessure mineure.

ATTENTION:

- Risk of property damage.
- Risque de dommages matériels.

NOTE: A note draws attention to important information.

TIP: A tip provides a suggestion to make working with the application easier.

Software Commands

Commands are written in the fonts shown here:

```
^AR Merge Scene, ,0p1 scene 1,1 ^B 51 ^W ^C.0  
[01] R0004 00300 00400 00800 00600 [02] 35 [17] [03]  
Esc [X1] * [X17] * [X20] * [X23] * [X21] CE ←
```

NOTE: For commands and examples of computer or device responses used in this guide, the character “0” is the number zero and “O” is the capital letter “o.”

Computer responses and directory paths that do not have variables are written in the font shown here:

```
Reply from 208.132.180.48: bytes=32 times=2ms TTL=32  
C:\Program Files\Extron
```

Variables are written in slanted form as shown here:

```
ping xxx.xxx.xxx.xxx -t  
SOH R Data STX Command ETB ETX
```

Selectable items, such as menu names, menu options, buttons, tabs, and field names are written in the font shown here:

```
From the File menu, select New.  
Click the OK button.
```

Specifications Availability

Product specifications are available on the Extron website, www.extron.com.

Extron Glossary of Terms

A glossary of terms is available at <https://www.extron.com/technology/glossary.aspx>.



Contents

Introduction 1

Guide Overview	1
Product Description.....	2
Licensed Third-Party Software Used in the Scalers	6
Key Features	7
Video Features.....	7
Audio Features	7
General Features	8
Control Methods.....	10

Installation 11

IN1606 and IN1608 Series Connector Overview	11
IN1606	11
IN1608 Series.....	11
Installation Overview	13
Rear Panel Connections	13
Power and Input Connections.....	14
Output Connections	16
Control Connections.....	17
IPCP Pro 350 Control Processor Connections	18
Connection Details	19
Analog Video Connection	19
Analog Audio Connection	20
HDMI Connections	21
Twisted Pair Recommendations for DTP and HDBaseT Communication	22

Operation 23

Front Panel Overview.....	23
Powering Up	24
Input Selection.....	24

On-Screen Display (OSD) Menu System	25
Menu Navigation Using Front Panel Controls.....	25
Menu Overview.....	25
Quick Setup Submenu.....	27
User Presets Submenu.....	28
Picture Controls Submenu.....	29
Input Submenu.....	30
Output Submenu	32
Audio Submenu.....	34
Advanced Submenu	36
Communication Submenu	39
Device Info Submenu.....	40
Front Panel Lockout (Executive Modes)	40
Reset Modes.....	41

SIS Configuration and Control 42

Host and Scaler Communication	42
Scaler-Initiated Messages	42
Copyright Information	42
Password Messages	43
Error Responses.....	43
Using the Command and Response Tables	44
Symbol Definitions.....	44
Command and Response Table.....	50

Configuration Software..... 67

Software Installation.....	67
Software Download Center Page.....	67
Software Connection	69
Device Discovery Panel.....	70
TCP/IP Panel	71
Offline Device Preview.....	72
Software Overview.....	73
Software Menu	73
Device Menu.....	76

Internal Web Pages..... 85

Using the Internal Web Pages.....	85
Accessing the Internal Web Pages.....	85
Turning Off Compatibility Mode.....	86
Navigating the Internal Web Pages	86
AV Controls Panel.....	86
Auto-Image Button	87
AV Inputs Buttons.....	87
Breakaway Audio Checkbox.....	87
Video and Audio Mute and Freeze Buttons... ..	87
Input and Output Information.....	87
Configuration Pages	88
Input and Output Configuration Page.....	88
EDID Minder Page	91
Image Settings Page.....	93
Size and Position Page.....	97
Audio Configuration Page	98
Preset Management Page	114
Device Settings Page.....	115
Hardware Pages.....	117
Unit Information Page	117
Device Name Page.....	118
Communication Settings Page.....	119
Update Firmware Page	120
Executive and Power Mode Page	121
Date and Time Page.....	122
Password Page	123
Reset Device Page	124

Reference Information 126

Mounting	126
Tabletop Mounting.....	126
Rack Mounting	126
Downloading Updated Firmware.....	128

Introduction

This section provides general information about this guide and the Extron IN1606 and IN1608 Series. Topics in this section include:

- [Guide Overview](#)
- [Product Description](#)
- [Licensed Third-Party Software Used in the Scalers](#)
- [Key Features](#)
- [Control Methods](#)

Guide Overview

The IN1606 and IN1608 Series includes the following scaling presentation switchers:

IN1606 and IN1608 DTP Models	IN1608 HDBT Models
<ul style="list-style-type: none">• IN1606 (60-1081-01)• IN1608 (60-1238-01)• IN1608 (60-1238-51)• IN1608 SA (60-1238-02)• IN1608 SA (60-1238-52)• IN1608 MA (60-1238-03)• IN1608 MA 70 (60-1238-53)• IN1608 IPCP SA (60-1238-12)• IN1608 IPCP MA 70 (60-1238-13)	<ul style="list-style-type: none">• IN1608 HDBT (60-1238-71)• IN1608 SA HDBT (60-1238-72)• IN1608 MA 70 HDBT (60-1238-73)• IN1608 IPCP SA HDBT (60-1238-75)• IN1608 IPCP MA 70 HDBT (60-1238-76)

NOTE: There are two different models for the IN1608 and IN1608 SA. Use their part numbers to distinguish them.

This guide provides instructions for experienced installers on how to install, configure, and operate the equipment.

In this guide, the models as listed above refer to their respective IN1606 or IN1608 Scaler Presentation Switcher model individually. The term “scaler” is used interchangeably to refer to all IN1606 and IN1608 models.

The following terms refer to groups of IN1608 models:

- The term “IN1608 Series” refers to all IN1608 models.
- The term “-0x models” refers to IN1608, IN1608 SA, and IN1608 MA models with DTP 230 extension.
- The term “-5x models” refers to IN1608, IN1608 SA, and IN1608 MA 70 models with DTP 330 extension.
- The term “IN1608 amplifier models” refers to IN1608 SA, IN1608 MA, IN1608 MA 70, IN1608 SA HDBT, and IN1608 MA 70 HDBT models.
- The term “SA models” or “stereo models” refers to IN1608 SA, IN1608 IPCP SA, IN1608 SA HDBT, and IN1608 IPCP SA HDBT models.
- The term “MA models” or “mono models” refers to IN1608 MA, IN1608 MA 70, IN1608 IPCP MA 70, IN1608 MA 70 HDBT, and IN1608 IPCP MA 70 HDBT models.
- The term “IN1608 IPCP models” refers to IN1608 IPCP SA, IN1608 IPCP MA 70, IN1608 IPCP SA HDBT, and IN1608 IPCP MA 70 HDBT models.
- The term “IN1608 DTP models” refers to IN1608, IN1608 SA, IN1608 MA, IN1608 MA 70, IN1608 IPCP SA, and IN1608 IPCP MA 70 models.
- The term “IN1608 HDBT models” refers to IN1608 HDBT, IN1608 SA HDBT, IN1608 MA 70 HDBT, IN1608 IPCP SA HDBT, and IN1608 IPCP 70 HDBT models.

Product Description

The Extron IN1606 is a six input, HDCP-compliant video scaler in a 1U, full rack width enclosure. The IN1608 Series are eight input, HDCP-compliant video scalers. The IN1608 and IN1608 HDBT are in a 1U, full rack width enclosure. The other IN1608 Series models are in 2U, full rack width enclosures.

The scalers include four HDMI inputs, two configurable analog video inputs, and two simultaneous HDMI outputs. The IN1608 Series also include two DTP inputs and one DTP or HDBaseT output with corresponding RS-232 and IR pass-through ports. The IN1608 amplifier and IN1608 IPCP models include a stereo or mono amplifier output.

The IN1606 and IN1608 Series accept a wide variety of video formats including HDMI, HDTV, RGB, and standard definition video. They feature an advanced video scaling engine with 1080i deinterlacing and seamless switching to deliver uncompromised picture quality for up to 1920x1200, including 1080p and 2K output resolutions. Automatic 3:2 and 2:2 pulldown detection maximizes the image detail and sharpness for content sources originating from film. The scalers also use a digital 3D adaptive comb filter that optimizes decoding of NTSC, PAL, and SECAM sources for integration into systems worldwide.

Enhanced audio features include analog stereo inputs, configurable mono or stereo outputs, two mic/line inputs with ducking and phantom power, and HDMI audio embedding and de-embedding. Designed for professional AV integration, the scalers offer flexible control options including Ethernet, RS-232, and USB. They provide two simultaneous HDMI outputs so that two displays can be driven simultaneously without the need for additional equipment.

To accommodate a variety of sources, the scalers feature four HDMI inputs plus two universal analog video inputs that can process RGB computer video, HDTV, component video, S-video, and composite video. They provide the capability to integrate digital and analog devices, with HDCP-compliance to enable integration of Blu-ray Disc players and cable or satellite HD receivers.

To enhance and simplify integration of HDMI sources and displays, the scalers feature two exclusive Extron technologies: EDID Minder and Key Minder. EDID Minder manages Extended Display Identification Data (EDID) communication between the display devices and input sources. For HDMI signals with protected content, Key Minder authenticates and maintains continuous HDCP-encryption between input and output devices. The scalers also feature SpeedSwitch technology that delivers exceptional switching speed for HDCP-encrypted content.

IN1608 IPCP models feature a built-in Extron IP Link Pro control processor for complete customizable control of an entire AV system. It has the same advanced features, processing power, and breakthrough technologies found in the standalone Extron IPCP Pro 350 control processors.

The scalers provide complete control of advanced audio configuration settings through internal web pages. Using the internal web pages, users can easily adjust audio input and output gain, attenuation, mixing, and ducking parameters.

The DTP twisted pair inputs and output receive and transmit signals from remote DTP transmitters and a receiver. Bidirectional RS-232 and IR signals can be inserted from a control system and transmitted over the single shielded twisted pair cable together with the video and audio, enabling control of a source or display. Additionally, IN1608 Series can send power to each of the DTP transmitters and receiver over the same shielded twisted pair cable, streamlining system design and installation. Most IN1608 Series models support a maximum transmission distance of 330 feet (100 meters) when paired with a DTP 330 series transmitter or receiver. However, when paired with DTP 230 series endpoints, they support a maximum transmission distance of 230 feet (70 meters).

NOTE: Despite having similar names, the -0x and -5x models support different maximum transmission distances.

- -0x models support a maximum transmission distance of 230 feet (70 meters).
- -5x models support a maximum transmission distance of 330 feet (100 meters).

The scalers feature front panel controls with an on-screen display (OSD) menu system for quick access to functions. Remote configuration and control are available via USB, RS-232, and Ethernet. Housed in 1U or 2U full rack width metal enclosures, the scalers can easily be integrated into many environments. They are ideal in boardrooms where superior performance is essential and in instructional environments for complete integration of digital and analog AV sources and displays.

The following diagram shows an example of a typical application for the IN1606.

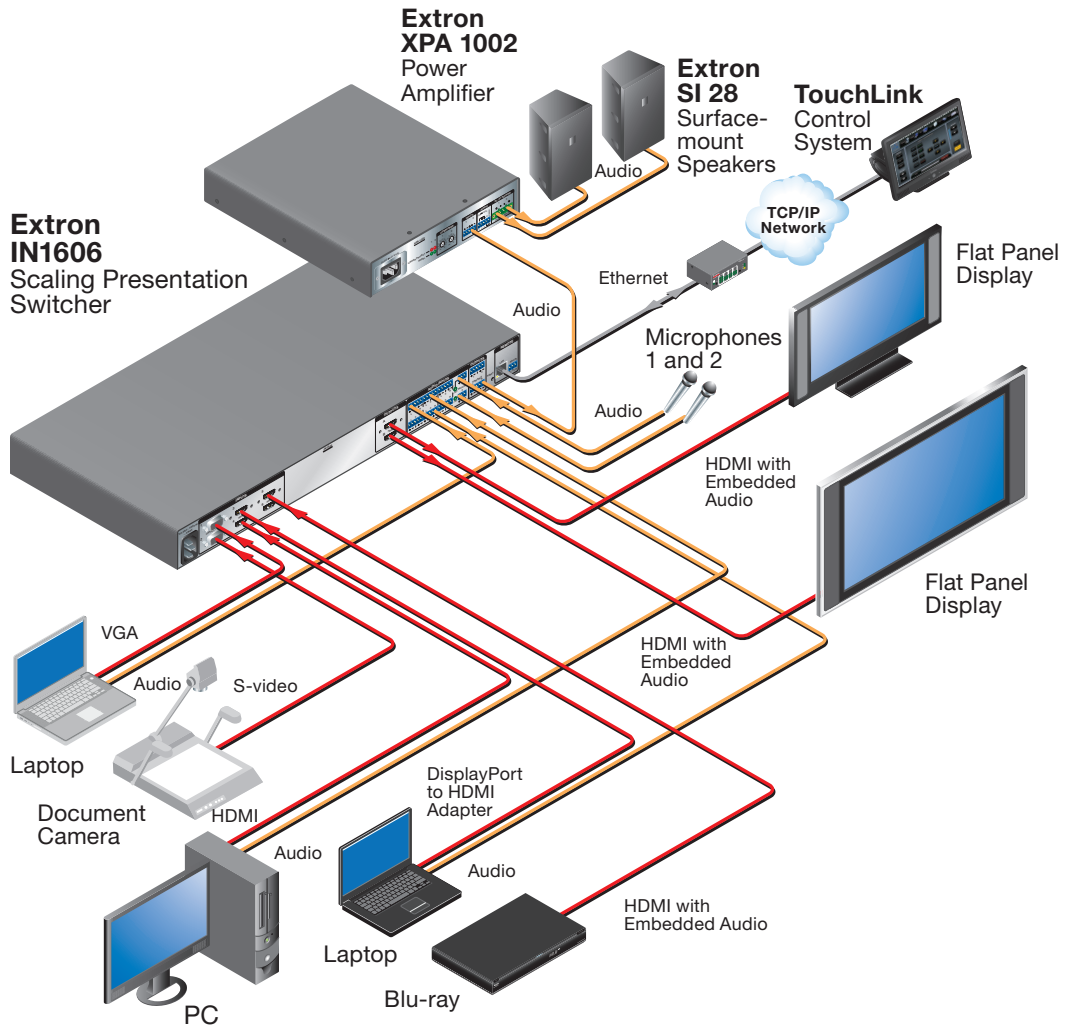

Figure 1. Typical IN1606 Application

The following diagram demonstrates an example of a typical application for the IN1608 SA.

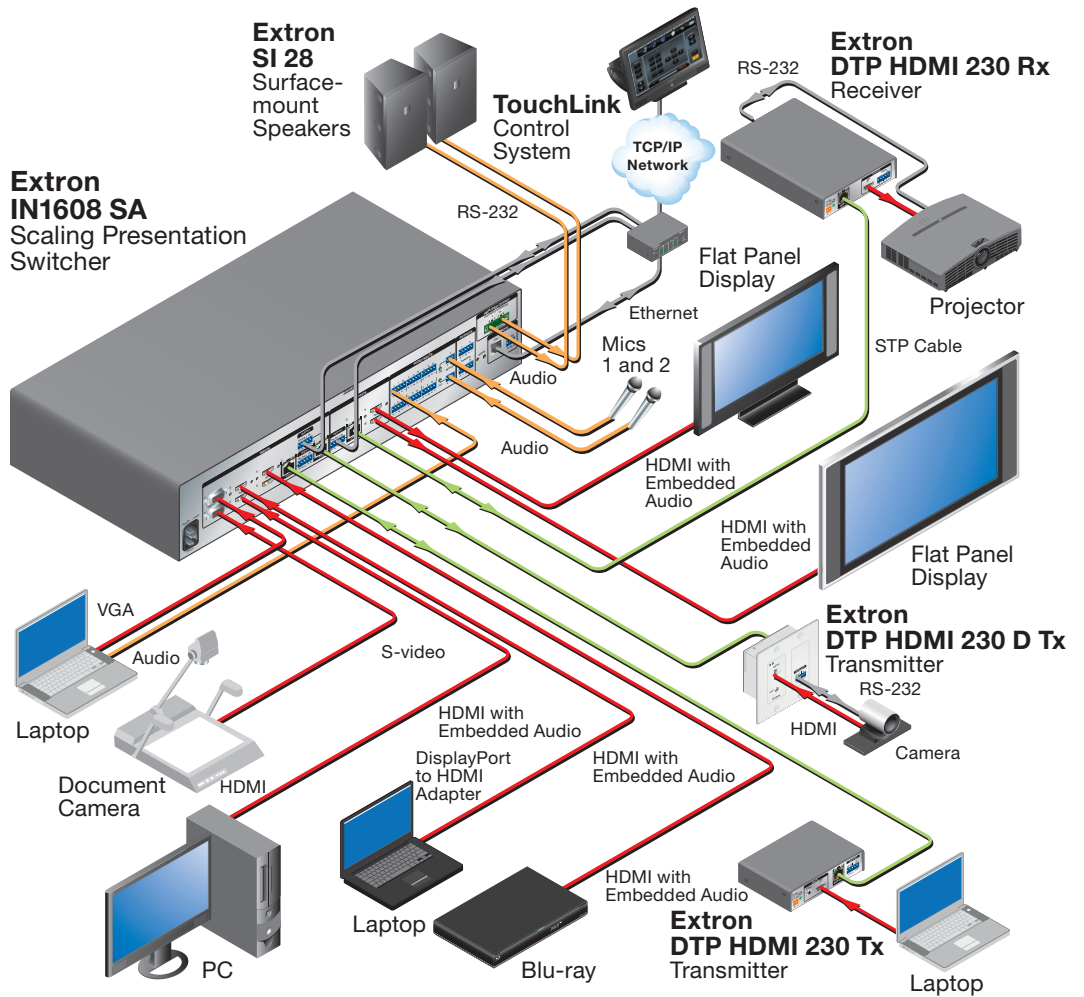

Figure 2. Typical IN1608 SA Application

Licensed Third-Party Software Used in the Scalers

The scalers use various licensed third-party software packages during operation. To view details about third-party packages and associated licensing, click the **License Information** button on the **Unit Information** page of the internal web pages (see **Unit Information Page** on page 117).

To view a copy of a listed package license, in the **License Information** dialog box, click the link in the **License** column for the relevant package. A copy of the package license opens in a separate page

The following table lists the licensed third-party software packages used by the scalers.

NOTE: Licensed third-party software packages used by the scalers are subject to change without notice.

Licensed Third-party Software Used in the IN1606 and IN1608 Series			
Package	License	Package	License
avahi	GNU LGPL v2.1	lighttpd	BSD
bstrib	BSD	Linux	GNU GPL v2
busybox	GNUPGL v2	lua	MIT
bzip2	BSD	lua-cjson	MIT
cjson	MIT	luafilesystem	MIT
expat	MIT	luasocket	MIT
ExtJS4	Sencha Commercial License	luastruct	MIT
fcgi	fcgi	mttd	GNU GPL v2
freetype	Free Type License	ncurses	MIT
gnupg-1.4.7	GNU LGPL v2	openssh	BSD
gpgme	GNU LGPL	openssl	OpenSSL
ifplugd	GNU GPL	PAM	BSD
jpeg	libjpeg	pcre	BSD
libassuan	GNU LGPL	psmisc	GNU GPL v2
libcgicc 3.2.3	GNU LGPL v2.1	qt	GNU LGPL v2.1
libcurl	ICS	socat	GNU GPL v2
libdaemon	GNU GPL v2.1	spawn-fcgi	BSD
libdnet	BSD	sqlite	Public Domain
libgpg	GNU GPL v2.1	xinetd	Custom
libcap	BSD	zlib	zlib
libpng	libpng license		

Key Features

Video Features

- **Multiple input types** — Allow for switching between HDMI and analog video sources. Two configurable analog inputs accept most standard analog video formats, including RGB, HD component video, S-video, and composite video signals.
- **HDMI, HDTV, RGB, and video source integration into presentation systems with audio switching** — Provides centralized switching for a wide range of AV sources.
- **Simultaneous video outputs** — Drives two or three displays depending on the model.
- **Selectable output rates** — Includes computer-video output rates from 640x480 to 1920x1200, and HDTV rates up to 1080p/60, and 2K (2048x1080).
- **Integrated DTP inputs and DTP output (IN1608 DTP only)** — Support digital signal transmission of HDMI, DisplayPort, DVI, 3G-SDI, or VGA plus control and analog audio over a single shielded twisted pair cable, providing high reliability and maximum performance on an easily installed cable infrastructure.
- **Integrated HDBaseT-compatible output (IN1608 HDBT only)** — Supports video and embedded audio, plus bidirectional RS-232 and IR signals to an HDBaseT-compatible display over a single shielded twisted pair cable.

Audio Features

- **Front panel output volume control** — Provides convenient access to volume control for program audio (default), mic volume, or output volume.
- **Two mic/line inputs with ducking and 48 volt phantom power** — Independently mixes microphone channels with program audio, which is embedded onto the HDMI outputs. Selectable 48 volt phantom power allows the use of condenser microphones.
- **Audio input gain and attenuation** — Adjusts gain or attenuation for each analog input to eliminate noticeable differences when switching between sources.
- **Advanced audio configuration** — Offers complete control of audio input and output gain, attenuation, mixing, and ducking parameters.
- **Audio breakaway** — Provides the capability to break an analog audio signal away from its corresponding video signal and route to the audio outputs.
- **Audio switching transitions** — Ramps audio output down and then ramps up to match the video during switching transitions.
- **Integrated audio delay** — Automatically delays audio output to compensate for latency introduced by the video processing.
- **HDMI audio embedding and de-embedding** — Embeds analog audio signals onto the HDMI output signals or extracts embedded HDMI 2-channel PCM audio to the analog outputs, or passes bitstream formats. Multi-channel bitstream formats can also be passed to HDMI outputs.
- **Mic ducking** — Reduces program audio when a microphone signal is detected.
- **Automatic clip limiter** — Detects the onset of clipping, automatically reducing gain to eliminate clipping. This protects speakers and amplifiers from distortion.

- **Available with energy efficient Class D stereo or mono amplifier (IN1608 amplifier and IN1608 IPCP models only)** — The SA models offer a stereo power amplifier with 50 watts per channel into 4 ohms and 25 watts per channel into 8 ohms, while the MA models offer a mono 70 volt power amplifier with 100 watts rms output. Both feature an Extron exclusive, highly efficient, advanced Class D amplifier design with CDRS - Class D Ripple Suppression, that provides a smooth, clean audio waveform and an improvement in signal fidelity over conventional Class D amplifier designs. CDRS eliminates the high frequency switching ripple characteristic of Class D amplifiers.

General Features

- **Interface format correction** — Enables or disables embedded audio and InfoFrames, and sets the correct color space for proper connection to HDMI and DVI displays.
- **Supported HDMI specification features** — Includes data rates up to 6.75 Gbps, Deep Color, and HD lossless audio formats.
- **HDCP-compliance** — Fully supports HDCP-encrypted sources, with selectable authorization for unencrypted content.
- **HDCP authentication and signal presence confirmation** — Provides real-time verification of HDCP status for each digital video input and output. This allows for quick signal and HDCP verification through front panel LEDs, RS-232, USB, or Ethernet, providing feedback to a system operator or helpdesk support staff.
- **HDCP Visual Confirmation** — Sends a full-screen green signal when HDCP-encrypted content is transmitted to a non-HDCP compliant display, providing immediate visual confirmation that protected content cannot be viewed on the display.
- **Aspect ratio control** — Controls the aspect ratio of the video output. Fill mode provides a full screen output. Follow mode preserves the original aspect ratio of the input signal.
- **Advanced scaling engine** — Performs image scaling and video format conversion at 30-bit precision for enhanced color accuracy and picture detail. Advanced deinterlacing for all interlaced signals up to 1080i delivers optimized image quality.
- **Bidirectional RS-232 and IR pass-through for AV device control (IN1608 Series only)** — Transmits RS-232 control and IR signals alongside the video signal over DTP or HDBaseT connections, allowing the remote device to be controlled without the need for additional cabling. Bidirectional control extension eliminates the need for control system wiring to remote devices.
- **Remote power to DTP extenders (IN1608 Series only)** — Provides power to two remote DTP transmitters (IN1608 Series) and a remote DTP receiver (IN1608 DTP only) over each twisted pair connection, eliminating the need for separate power supplies at the remote units.
- **Integrated IP Link Pro control processor (IN1608 IPCP models only)** — Offers complete AV system control.
- **Key Minder** — Authenticates and maintains continuous HDCP encryption between input and output devices to ensure quick and reliable switching in professional AV environments, while enabling simultaneous distribution of a single source signal to one or more displays.
- **EDID Minder** — Manages EDID communication between connected devices. It ensures that all sources power up properly and reliably output content for display.
- **SpeedSwitch Technology** — Provides high-speed switching for HDCP-encrypted content.

- **Seamless switching** — Enhances presentations by eliminating distractions during switching with seamless cut through black and fade through black transition effects.
- **Image freeze control** — Freezes a live image.
- **Auto-Image** — Automatically optimizes the image by analyzing and adjusting to the video input signal when activated.
- **Auto Input Memory** — Automatically stores size, position, and picture settings based on the incoming signal when activated. When the same signal is detected again, these image settings are automatically recalled from memory.
- **On-screen menus** — Allows for easy system setup using the front panel controls. Key parameters such as input and output video formats and resolutions are grouped on the initial Quick Setup submenu, while additional submenus provide full control over other functions and settings.
- **Output Standby Mode** — Automatically mutes video and sync output to the display device when no active input signal is detected. This allows the projector or flat-panel display to automatically enter into standby mode to save energy and enhance lamp or panel life.
- **Output muting control** — Provides the capability to mute one or all outputs at any time. This allows content to be viewed on a local monitor prior to appearing on the main presentation display.
- **Power Save Mode** — Conserves energy when the unit is not in use.
- **Picture controls** — Include controls for brightness, contrast, color, tint, detail, horizontal and vertical positioning, and sizing.
- **Automatic 3:2 and 2:2 pulldown detection** — Helps maximize image quality for NTSC, PAL, and 1080i sources that originated from film.
- **Quad standard video decoding** — Provides advanced decoding of composite NTSC 3.58, NTSC 4.43, PAL, and SECAM for integration into systems worldwide using a temporal 3D adaptive comb filter.
- **User presets** — Store and recall optimized image settings.
- **Internal video test patterns and pink noise generator** — Offers several video test patterns and audio pink noise to facilitate proper system setup and calibration of display devices.
- **Front panel security lockout (executive modes)** — Locks out all front panel functions, except for input selection and volume control. All features remain available through Ethernet, USB, or RS-232 control.
- **Ethernet monitoring and control** — Enables control and proactive monitoring over a LAN, WAN, or the Internet. An intuitive web interface is included for full configuration of the device.
- **Built-in web pages** — Enables the use of a standard browser for full control and troubleshooting over an intuitive web interface.
- **RS-232 control port** — Enables the use of serial commands for integration into a control system. Extron products use the Simple Instruction Set (SIS) command protocol, a set of basic ASCII commands that allow for quick and easy programming.
- **Front panel USB configuration port** — Enables easy configuration without having to access the rear panel.
- **Rack-mountable 1U (IN1606, IN1608, and IN1608 HDBT) or 2U (all other IN1608 Series models), full rack width metal enclosure**

- **Includes LockIt HDMI cable lacing brackets**
- **Internal universal power supply** — Provides worldwide power compatibility. The 100-240 VAC, 50-60 Hz international power supply is highly reliable and energy-efficient.

Control Methods

Control the scalers using one or more of the following methods:

- The front panel controls and the on-screen display menu (see **On-Screen Display (OSD) Menu System** on page 25).
- A computer, a touch screen panel, or any other device that sends and receives serial communications through the USB, RS-232, or Ethernet port. Use the Extron DataViewer utility on the connected device to enter SIS commands (see **SIS Configuration and Control** beginning on page 42).
- Internal web pages, providing a web browser-based interface for controlling the switcher from a computer over a LAN network (see **Internal Web Pages** beginning on page 85).
- Ethernet control via IP Link (IN1608 IPCP only), enabling the switcher to be controlled and actively monitored over a LAN, WAN, or the Internet.

NOTE: See the *IPCP Pro Series User Guide* at www.extron.com for control options of the IPCP Pro 350 control processor.

- The Extron Product Configuration Software (PCS) on a computer with a Windows® operating system (see **Configuration Software** beginning on page 67).

Installation

This section contains information on how to connect cables to the IN1606 and IN1608 Series models. Topics in this section include:

- [IN1606 and IN1608 Series Connector Overview](#)
- [Installation Overview](#)
- [Rear Panel Connections](#)
- [Connection Details](#)

IN1606 and IN1608 Series Connector Overview

IN1606

The IN1606 (see figure 3) features four HDMI and two universal analog video inputs along with stereo balanced or unbalanced audio connectors for each input. It also features two mic/line audio inputs. Outputs include two HDMI outputs and two variable audio outputs. Control connectors include a Remote RS-232 and LAN connector.

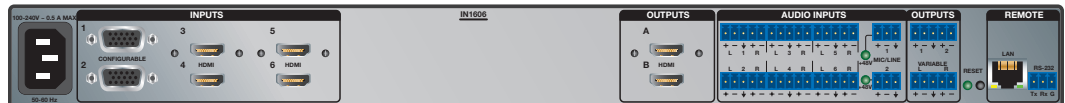

Figure 3. IN1606 Rear Panel

IN1608 Series

All IN1608 Series models include the same IN1606 connectors with the addition of several other connectors.

IN1608

In addition to the IN1606 connectors, all IN1608 Series models (see figure 4) include DTP inputs and a TP output with corresponding RS-232 and IR Over DTP (IN1608 DTP only) or RS-232 and IR Over HDBT (IN1608 HDBT only) pass-through connectors.

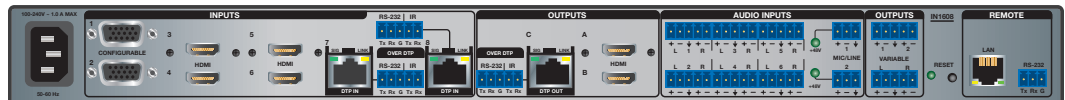
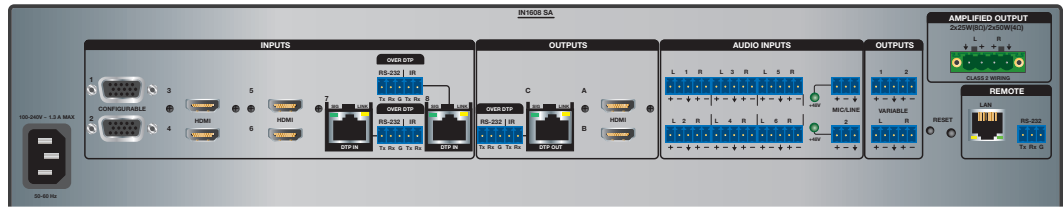

Figure 4. IN1608 Rear Panel

IN1608 amplifier models

The IN1608 amplifier models (see figure 5) feature all the connectors of the IN1608 plus an amplified audio connector. The SA models feature a 4-pole captive screw connector while the MA models feature a 2-pole captive screw connector for amplified audio output.



IN1608 SA

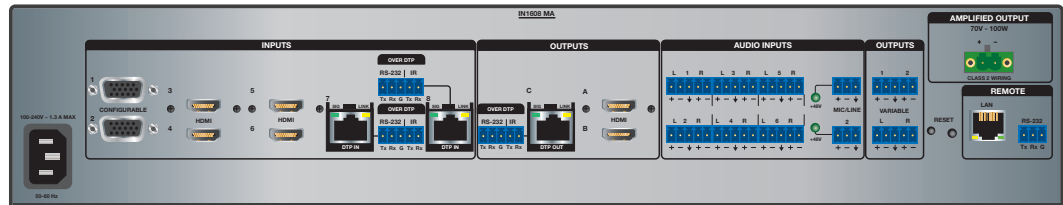

IN1608 MA

Figure 5. IN1608 SA and IN1608 MA Rear Panels

IN1608 IPCP models

The IN1608 IPCP models (see figure 6) feature the connectors of an SA model or an MA model (depending on the model) plus an IPCP Pro 350 control processor. The LAN connector is incorporated in the IPCP Pro 350 control processor instead of the scaler. Otherwise, the IN1608 IPCP SA and IN1608 IPCP SA HDBT include all of the connectors of the SA models and the IN1608 IPCP MA 70 and IN1608 IPCP MA 70 HDBT include all of the connectors of the MA models.

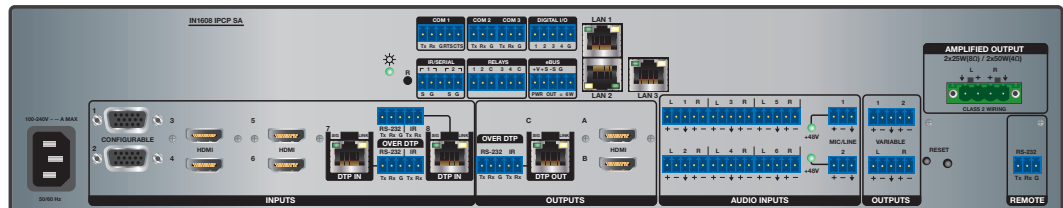

IN1608 IPCP SA

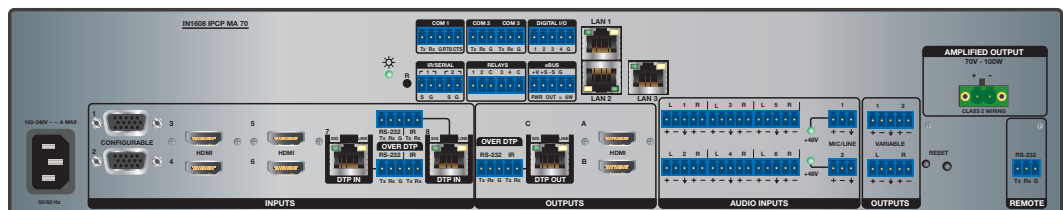

IN1608 IPCP MA 70

Figure 6. IN1608 IPCP SA and IN1608 IPCP MA 70 Rear Panels

IN1608 HDBT models

The IN1608 HDBT models feature the same connectors as their IN1608 DTP counterparts except for the remote output. For IN1608 HDBT models, the remote output is an HDBaseT output instead of a DTP output.

Installation Overview

1. Turn off or disconnect all related equipment. Ensure that video sources and output displays are all turned off and disconnected from the power source.
2. (Optional) Mount the scaler (see [Mounting](#) on page 126).
3. Connect input sources (see [Power and Input Connections](#) on the next page).
4. Connect output devices (see [Output Connections](#) on page 16).
5. Connect desired control devices (see [Control Connections](#) on page 17 or [IPCP Pro 350 Control Processor Connections](#) on page 18).
6. Connect a power source to the scaler (see [Power and Input Connections](#) on the next page).
7. Configure the scaler (see [Control Methods](#) on page 10).

Rear Panel Connections

Figure 7 shows the rear panel connectors available on most IN1606 and IN1608 Series models (the IN1608 SA is used as an example). For information on the IPCP Pro 350 control processor module, see [IPCP Pro 350 Control Processor Connections](#) on page 18.

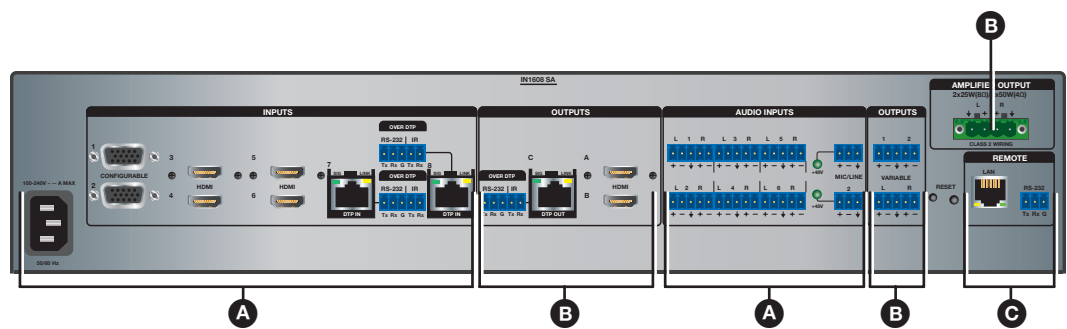

- A** Power and input connectors (see page 14)
- B** Output connectors (see page 16)
- C** Control connections (see page 17-18)

Figure 7. Rear Panel Connectors (IN1608 SA)

Power and Input Connections

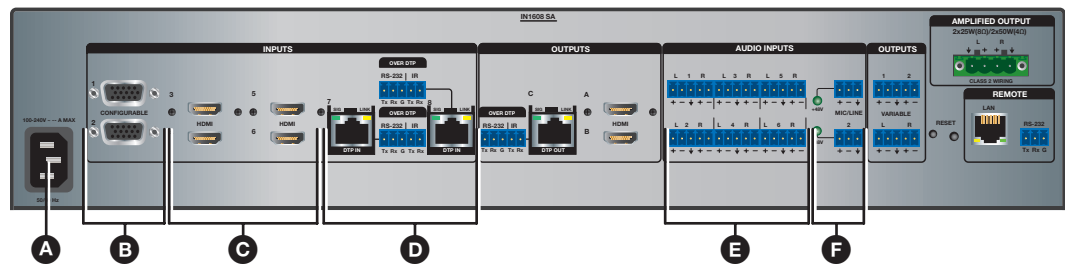

- A AC power connector**
- B Analog video input connectors** — inputs 1 and 2
- C HDMI input connectors** — inputs 3-6
- D DTP input and corresponding RS-232/IR Over DTP connectors** — inputs 7 and 8
- E Analog audio input connectors** — inputs 1-6
- F Mic/Line connectors** — inputs 1 and 2

Figure 8. Power and Input Connectors (IN1608 SA)

- A AC power connector** — Connect the standard IEC power cord from a 100 to 240 VAC, 50-60 Hz power source into this connector. The front panel control and input selection buttons light in sequence during power-up.
- B Analog video input connectors** — Connect video sources to the 15-pin HD connectors. Each accepts RGB, YUV, RGBcV, S-video, and composite video (see [Analog Video Connection](#) on page 19).

- C HDMI input connectors** — Connect video sources to the HDMI connectors.

TIP: Use Extron HDMI LockIt Lacing Brackets to secure HDMI cables to the device (see [HDMI Connections](#) on page 21).

- D DTP input connectors (IN1608 Series only)** — Connect DTP transmitters to the DTP IN RJ-45 connectors to send and receive DTP signals over a single twisted pair cable (see [Twisted Pair Recommendations for DTP and HDBaseT Communication](#) on page 22 for wiring and cable recommendations).

NOTE: Depending on the connected transmitters, the DTP input can travel up to 330 feet (100 meters) or 230 feet (70 meters) without a loss of signal integrity.

- The -0x models of the IN1608, IN1608 SA, and IN1608 MA are capable of DTP 230 transmission.
- All other models are capable of DTP 330 transmission.

This connection supports the following:

- HDCP-compliant digital video
- Embedded digital audio de-embedding from the TMDS source or analog audio
- DTP standard RS-232 and IR pass-through signals on associated 5-pole captive screw connectors.
- Remote power to DTP transmitters

ATTENTION:

- Do not connect these connectors to a computer or telecommunications network.
- Ne connectez pas ces ports à des données informatiques ou à un réseau de télécommunications.
- DTP remote power is intended for indoor use only. No part of the network that uses DTP remote power should be routed outdoors.
- L'alimentation DTP à distance est destiné à une utilisation en intérieur seulement. Aucune partie du réseau qui utilise l'alimentation DTP à distance ne peut être routée en extérieur.

- **Signal LED** — Lights when the scaler is receiving an active video signal from a DTP transmitter.
- **Link LED** — Lights when a valid link is established to a DTP transmitter.

RS-232 Over DTP port — To pass bidirectional serial control between DTP-compatible devices, connect a control device to the 5-pole captive screw connector. This port includes only the 3 poles labeled “RS-232.”

IR Over DTP port — To transmit and receive IR signals, connect a control device to the 5-pole captive screw connector. This port includes only the 2 poles labeled “IR” and shares the ground pole with the RS-232 port.

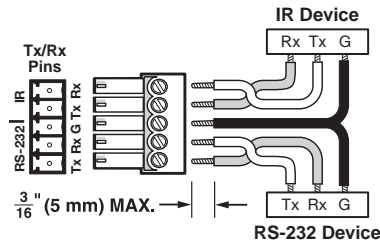

Figure 9. RS-232 and IR Over DTP Wiring

NOTES:

- RS-232 and IR data can be transmitted simultaneously.
- The ground pole is shared between the RS-232 and IR devices.

- E Analog audio input connectors** — Connect audio sources to the 5-pole captive screw connectors associated with the desired input. Wire the connector for line level, balanced or unbalanced, analog stereo (see **Analog Audio Connection** on page 20).
- F Mic/line connectors** — Connect unbalanced audio sources to the 3-pole captive screw connectors for configurable mic or line level inputs.

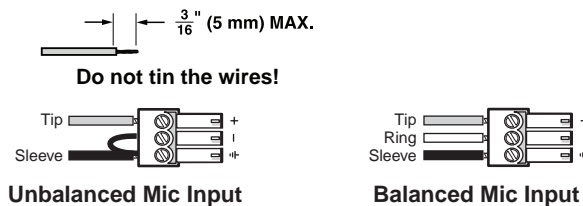
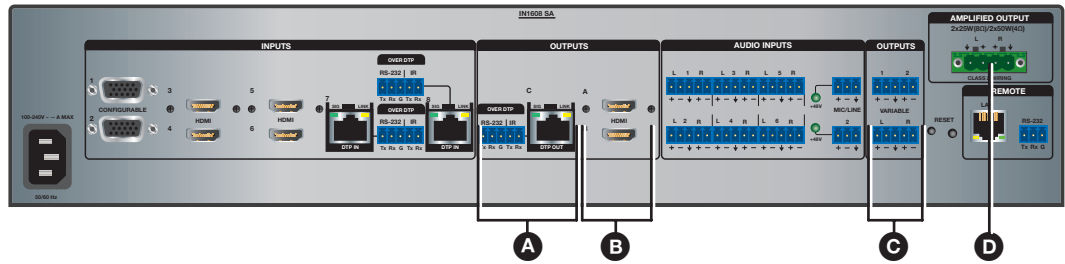

Figure 10. Mic/Line Connector Wiring

Output Connections



- A** TP output and corresponding RS-232/IR Over TP connector — output C
- B** HDMI output connectors — outputs A and B
- C** Analog audio output connectors
- D** Amplified audio output connector

Figure 11. Output Connectors (IN1608 SA)

- A** **TP output connector (IN1608 Series only)** — Depending on the IN1608 model, connect either a DTP receiver (IN1608 DTP models only) or HDBaseT-compatible device (IN1608 HDBT models only) to the RJ-45 connector (see [Twisted Pair Recommendations for DTP and HDBaseT Communication](#) on page 22).

NOTE: Depending on the connected receiver, the DTP output signal can travel up to 330 feet (100 meters) or 230 feet (70 meters) without a loss of signal integrity.

- The -0x models of the IN1608, IN1608 SA, and IN1608 MA are capable of DTP 230 transmission.
- All other IN1608 DTP models are capable of DTP 330 transmission.

Signal Support	
DTP output	HDBaseT output
<ul style="list-style-type: none"> • HDCP-compliant digital video • Re-embedded program audio into the TMDS output or analog audio • DTP standard RS-232 and IR pass-through signals on the associated 5-pole captive screw connector • Remote power to a DTP receiver 	<ul style="list-style-type: none"> • HDCP-compliant digital video • Re-embedded program audio into the TMDS output • RS-232 and IR pass-through signals on the associated 5-pole captive screw connector

ATTENTION:

- Do not connect this connector to a computer or telecommunications network.
- Ne connectez pas ce port à des données informatiques ou à un réseau de télécommunications.
- DTP remote power is intended for indoor use only. No part of the network that uses DTP remote power should be routed outdoors.
- L'alimentation DTP à distance est destiné à une utilisation en intérieur seulement. Aucune partie du réseau qui utilise l'alimentation DTP à distance ne peut être routée en extérieur.

- **Signal LED** — Lights when the scaler is sending a signal.
- **Link LED** — Lights when a valid link is established.

RS-232 Over DTP port or RS-232 Over HDBT port — To pass bidirectional serial control, connect a control device to the 5-pole captive screw connector. This port includes only the 3 poles labeled “RS-232.”

IR Over DTP port or IR Over HDBT port — To transmit and receive IR signals, connect a control device to the 5-pole captive screw connector. This port includes only the 2 poles labeled “IR” and shares the ground pole with the RS-232 port.

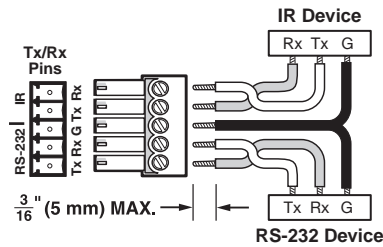

Figure 12. RS-232 and IR Over DTP or HDBT Wiring

NOTES:

- RS-232 and IR data can be transmitted simultaneously.
- The ground pole is shared between the RS-232 and IR sides.

- B HDMI output connectors** — Connect display devices to the HDMI connectors. Use either of these connectors for a local monitor to display the On-screen Display (OSD) menu (see [Operation](#), beginning on page 23).

TIP: Use Extron HDMI LockIt Lacing Brackets to secure HDMI cables to the device (see [HDMI Connections](#) on page 21).

- C Analog audio output connectors** — Connect audio output devices to these 5-pole captive screw connectors. Wire the connector for line level, balanced or unbalanced, analog stereo (see [Analog Audio Connection](#) on page 20).
- D Amplified audio output connector (IN1608 amplifier models only)** — Connect speakers to the 4-pole or 2-pole captive screw connector.

Control Connections

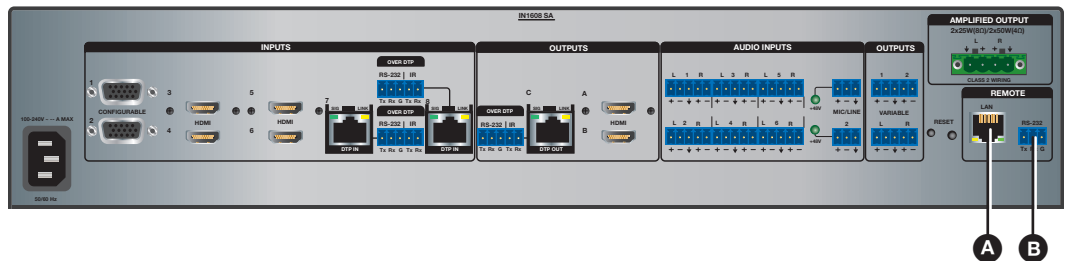

- A LAN connector**
- B Remote RS-232 connector**

Figure 13. Control Connectors (IN1608 SA)

- A LAN connector** — Connect a computer network to this RJ-45 connector. Use a patch cable to connect to a switch, hub, or router. Wire the connector as shown below.

Pin	T568A Wire Color	T568B Wire Color
1	White-green	White-orange
2	Green	Orange
3	White-orange	White-green
4	Blue	Blue
5	White-blue	White-blue
6	Orange	Green
7	White-brown	White-brown
8	Brown	Brown

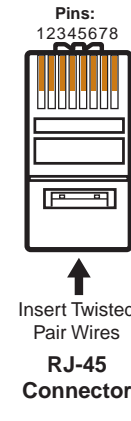

LEDs on this connector indicate link and activity status.

- B Remote RS-232 connector** — Connect a host device to this 3-pole captive screw connector for RS-232 serial control. The default baud rate is 9600.

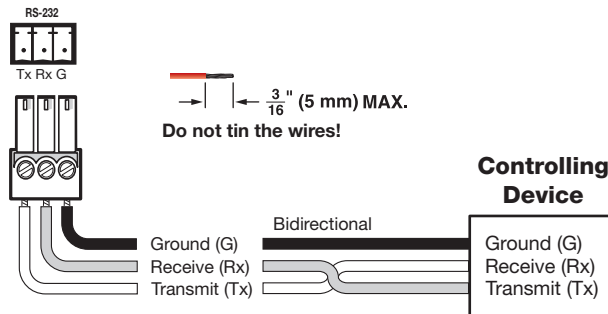

Figure 14. RS-232 Wiring

IPCP Pro 350 Control Processor Connections

The IN1608 IPCP models include a built-in IPCP Pro 350 control processor. For these models, the LAN connector is incorporated in the IPCP Pro 350 control processor. For installation details of this control processor, see the *IPCP Pro Series User Guide* at www.extron.com.

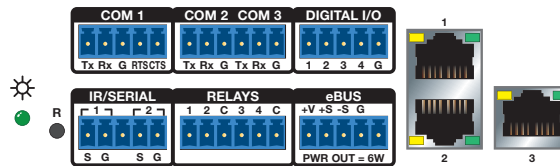
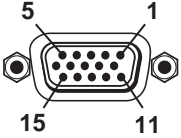

Figure 15. IPCP Pro 350 Control Processor

Connection Details

Analog Video Connection

Pinout Table for 15-pin HD Connectors						
Pin	RGBHV	RGBs	RGBcvS	Component	S-video	Composite
1	Red	Red	Red	R-Y		
2	Green	Green	Green	Y	Luma	Video
3	Blue	Blue	Blue	B-Y	Chroma	
4						
5	H Sync Return	C Sync Return	Sync Return			
6	Red Return	Red Return		R-Y Return		
7	Green Return	Green Return		Y Return	L Return	Video Return
8	Blue Return	Blue Return		B-Y Return	C Return	
9						
10	V Sync Return/ DDC Return	DDC Return				
11						
12	EDID/DDC	EDID/DDC				
13	H Sync	C Sync	Composite Video			
14	V Sync					
15	EDID/DDC	EDID/DDC				

Analog Audio Connection

Wire the audio input and output connectors as shown in figure 16. Use the supplied tie wrap to strap the audio cable to the extended tail of the connector. This does not apply to the amplified audio output connector on the SA and MA models.

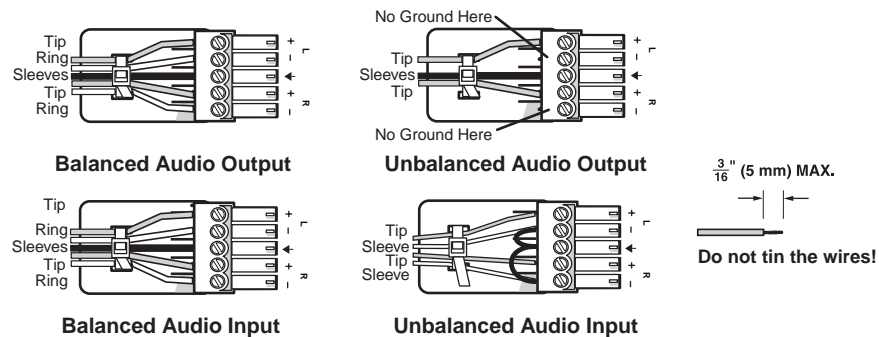

Figure 16. Analog Audio Wiring Configuration

ATTENTION:

- For unbalanced audio, connect the sleeves to the ground contact. Do not connect them to negative (–) contacts.
- Pour l'audio asymétrique, connectez les manchons au contact au sol. Ne PAS connecter les manchons aux contacts négatifs (–).
- The length of the exposed wires in the stripping process is important. The ideal length is 3/16 inch (5 mm). If the exposed portion is longer, the wires may touch, causing a short circuit between them. If the exposed wires are shorter, they can be easily pulled out, even if tightly fastened by the captive screws.
- La longueur des câbles exposés est importante lorsque l'on entreprend de les dénuder. S'ils sont un peu plus longs, les câbles exposés pourraient se toucher et provoquer un court circuit. S'ils sont un peu plus courts, ils pourraient sortir, même s'ils sont attachés par les vis captives.
- Do not tin the wires. Tinned wire does not hold its shape and can become loose over time.
- Ne pas étamer les câbles. Les câbles étamés ne sont pas aussi bien fixés dans les terminaisons des connecteurs à vis captives et pourraient sortir.

HDMI Connections

Use an Extron LockIt cable lacing bracket to secure HDMI cables to the device. One bracket secures up to two HDMI cables in a stacked formation (see figure 17), but each stacked formation supports up to two brackets for added support if necessary.

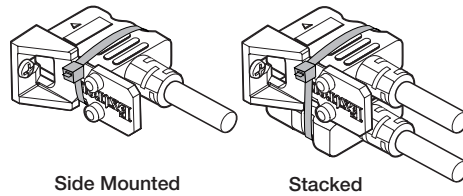

Figure 17. LockIt Cable Lacing Bracket Mounting Options

To install an LockIt cable lacing bracket, perform the following:

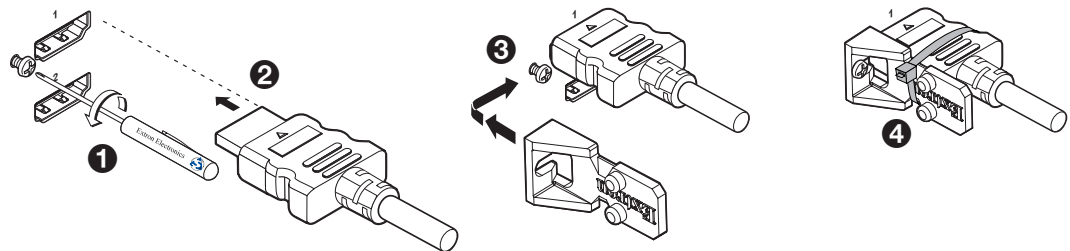

Figure 18. LockIt Cable Lacing Bracket Mounting Instructions

1. Loosen the side HDMI connection mounting screw (see figure 18, **1**) so there is enough space between the device and the screw head to fit the cable lacing bracket. Do not remove the screw from the device.
2. Plug the HDMI cables into the panel connection (**2**).
3. Place the bracket on the screw and against the HDMI cables, and then tighten the screw to secure the bracket (**3**).

ATTENTION:

- Do not overtighten the screw. The shield to which it is fastened is very thin and can easily be stripped.
 - Ne serrez pas trop la vis. Le blindage auquel elle est attachée est très fin et peut facilement être dénudé.
4. Loosely place the included tie wrap around the HDMI connector and the LockIt lacing bracket (**4**).
 5. While holding the connector securely against the lacing bracket, use pliers or a similar tool to tighten the tie wrap, then remove any excess length.

Twisted Pair Recommendations for DTP and HDBaseT Communication

Use the following pin configurations for shielded twisted pair cables used for DTP or HDBaseT communication.

Pin	T568B Wire Color
1	White-orange
2	Orange
3	White-green
4	Blue
5	White-blue
6	Green
7	White-brown
8	Brown



Figure 19. Twisted Pair Cable Configuration

Supported cables

The scalars are compatible with shielded twisted pair (F/UTP, SF/UTP, and S/FTP) cable.

ATTENTION:

- Do not use Extron UTP23SF-4 Enhanced Skew-Free AV UTP cable or STP201 cable to link the device with DTP transmitters or receivers.
- N'utilisez pas le câble AV Skew-Free UTP version améliorée UTP23SF d'Extron ou le câble STP201 pour relier le appareil avec les émetteurs ou les récepteurs DTP.

Cable recommendations

Extron recommends using the following practices to achieve full transmission distances and reduce transmission errors.

- Use the following Extron XTP DTP 24 SF/UTP cables and connectors for the best performance:
 - **XTP DTP 24/1000** Non-Plenum 1000' (305 m) spool 22-236-03
 - **XTP DTP 24P/1000** Plenum 1000' (305 m) spool 22-235-03
 - **XTP DTP 24 Plug** Package of 10 101-005-02
- If not using XTP DTP 24 cable, at a minimum, Extron recommends 24 AWG, solid conductor, STP cable with a minimum bandwidth of 400 MHz.
- Terminate cables with shielded connectors to the TIA/EIA-T568B standard.
- Limit the use of more than two pass-through points, which may include patch points, punch down connectors, couplers, and power injectors. If these pass-through points are required, use shielded couplers and punch down connectors.

NOTE: When using shielded twisted pair cable in bundles or conduits, consider the following:

- Do not exceed 40% fill capacity in conduits.
- Do not comb the cable for the first 20 meters, where cables are straightened, aligned, and secured in tight bundles.
- Loosely place cables and limit the use of tie wraps or hook-and-loop fasteners.
- Separate twisted pair cables from AC power cables.

Operation

This section contains information on the front panel operation, on-screen display menu system, and reset modes of the scalers. Topics in this section include:

- [Front Panel Overview](#)
- [Powering Up](#)
- [Input Selection](#)
- [On-Screen Display \(OSD\) Menu System](#)
- [Front Panel Lockout \(Executive Modes\)](#)
- [Reset Modes](#)

Front Panel Overview

The scalers all have the same front panel features except for the number of input selection buttons and input and output LED indicators. The IN1608 IPCP models also include LED indicators for the IPCP Pro control processor.

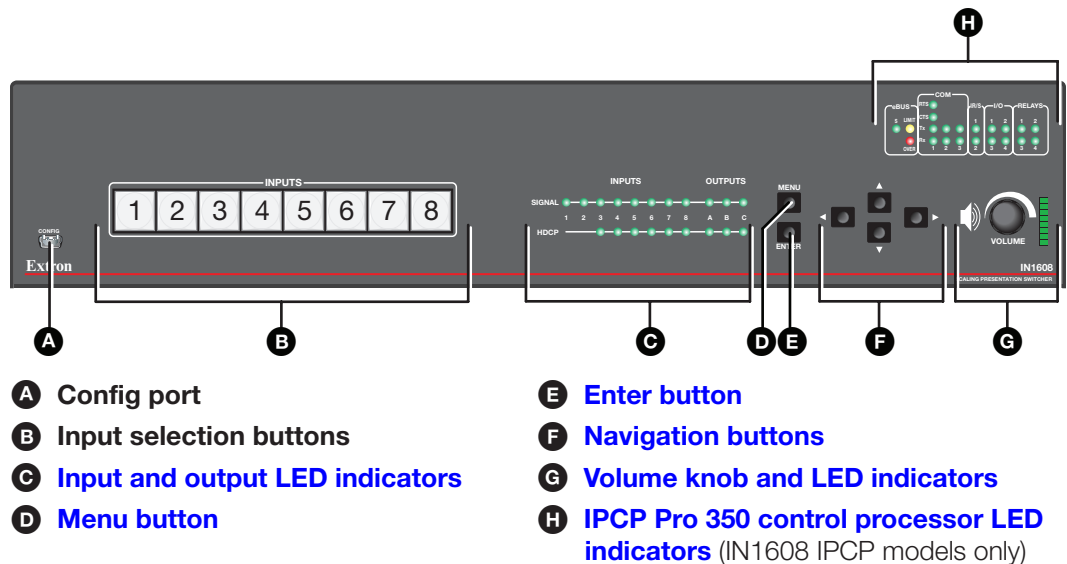

Figure 20. Front Panel Features (IN1608 IPCP SA)

- A Config port** — Connect a host device to the USB mini-B connector.
- B Input selection buttons** — Press one of these buttons to select an input. The number of input selection buttons depends on the scaler model (the IN1606 has six and the IN1608 Series models have eight). The buttons light different colors for different types of inputs (see [Input Selection](#) on the next page for button light definitions).

C Input and output LED indicators

The number of input and output LED indicators depends on the scaler model.

Input signal LEDs — Light for each input when active video content is detected.

Output signal LEDs — Light green when active video is being output or blink amber when video output and sync are disabled from the scaler.

Input HDCP LEDs — Light for each input signal that is HDCP-encrypted. Analog inputs 1 and 2 cannot be HDCP-encrypted.

Output HDCP LEDs — Light for the active output when it is HDCP-encrypted.

D **Menu button** — Press this button to enter or exit the OSD menu system.

E **Enter button** — Press this button to select options from the OSD menu system.

F **Navigation buttons** — Press any of the four buttons to navigate the OSD menu system or change values of adjustable features.

G **Volume knob** — Rotate this knob to adjust output, program (default), or mic volume.

Volume LEDs — Light in order from bottom to top according to the audio volume level. There are eight LED steps from 1% (-99 dB) to 99% (-1 dB). Every quarter turn of the volume knob equates to a one step increment (about 12.5%). When the volume is muted (0%), the bottom LED blinks. When the volume is at 100%, the top LED blinks.

H **IPCP Pro 350 control processor LED indicators** — Light to indicate the status of various settings and connections on the IPCP Pro 350 control processor (see the *IPCP Pro Series User Guide* at www.extron.com for more details).

Powering Up

When power is applied to the scaler, the **Input** selection buttons light different colors before illuminating just the selected input.

- For the IN1606, the buttons light red, amber, and then green.
- For IN1608 Series models, the buttons light amber and then green.

Input Selection

Press any of the **Input** selection buttons on the front panel to select an input. The current active input lights as follows:

Input Selection Button Lights	
Color	Signal
Amber	Audio and video
Green	Video only
Red	Audio only

On-Screen Display (OSD) Menu System

The OSD menu is used primarily for the initial setup of the device (for other methods of control, see **Control Methods** on page 10). The OSD menu presents configuration options on a local monitor and can be adjusted with front panel controls.

NOTE: The OSD menu has a fixed time-out of 60 seconds.

Menu Navigation Using Front Panel Controls

- **Menu button** — Press the **Menu** button to activate or exit the OSD menu, deselect a submenu, or cancel a pending change.
- **Enter button** — Press the **Enter** button to activate the OSD menu, select submenus or submenu items, or accept pending changes.
- **Navigation buttons** — Press the **Up** (▲) button or the **Down** (▼) button to navigate submenus or submenu items. Press the **Right** (▶) button to access currently selected submenus or submenu items. Press the **Left** (◀) button to exit currently selected submenus or submenu items. Also use the navigation buttons to adjust settings according to specific setting directions.
- **Input selection buttons** — Press any of the Input selection buttons to change the selected input.

Menu Overview

In the OSD menu, the IP address and firmware version are displayed in the top border. The active input settings and output resolution are displayed in the bottom border. The OSD menu contains nine submenus with various submenu items of adjustable settings or device information (see the table below). Use the **Menu**, **Enter**, and navigation buttons to navigate the OSD menu.

Submenus	Submenu Items							
Quick Setup	Auto-Image	Input Format	EDID	Output Resolution	Audio Mute	Test Pattern	DHCP Mode	IP Address
User Presets	Recall	Save	Clear					
Picture Controls	Image Position	Image Size	Brightness/Contrast	Color/Tint	Detail			
Input	Auto-Image	Input Format	Film Mode	Horizontal/Vertical Start	Horizontal/Vertical Active	Total Pixels/Phase	HDCP Authorization	EDID
Output	Resolution	HDMI "A" Format	HDMI "B" Format	Out "C" Format (IN1608)	HDCP Notification			
Audio	Audio Mute	Audio Format	Gain	Mic/Line 1 Gain/Phantom	Mic/Line 2 Gain/Phantom	Mic/Line Volume	Program Volume	Output 1/2 Format
Advanced	Test Pattern	Screen Saver/Timeout	Auto-Image	Aspect Ratio	Auto Memory	Overscan	Auto Switch	Factory Reset
Communication	Remote Port	MAC Address	DHCP	IP Address	Subnet Mask	Gateway		
Device Info (Read Only)	Unit Name	Firmware	Temperature	Active Input Details	Active Output Details	Detected Displays		

NOTE: The Communication submenu is normally locked. Press and hold the **Enter** button for 10 seconds to unlock the submenu items.

To open the OSD menu:

1. Connect a display device to an HDMI output connector (see [figure 11](#), **B**, on page 16).
2. Press the **Menu** or **Enter** button to open the OSD menu.

To navigate the OSD menu:

1. Press the **Up** or **Down** button to navigate the nine submenus. The [table](#) on the previous page shows the nine submenus and their respective submenu items.
2. Press the **Enter** or **Right** button to access the submenu items of the selected submenu.
3. Press the **Up** or **Down** button to navigate the available submenu items.
4. Press the **Menu** button to return to the list of submenus.

To adjust a submenu item:

1. Navigate to an adjustable submenu item and press the **Enter** or **Right** button to select the submenu item.
2. Press the **Left** or **Right** button to adjust the setting or select a specific adjustable setting within the selected submenu item.

If the selected submenu item has multiple adjustable settings, press the **Up** or **Down** button to select a value.
3. Press the **Enter** button to accept the new value.

Press the **Menu** button to cancel any pending changes.

To exit the OSD menu:

From the list of submenus, hold the **Menu** button for 3 seconds to exit the OSD menu.

Quick Setup Submenu

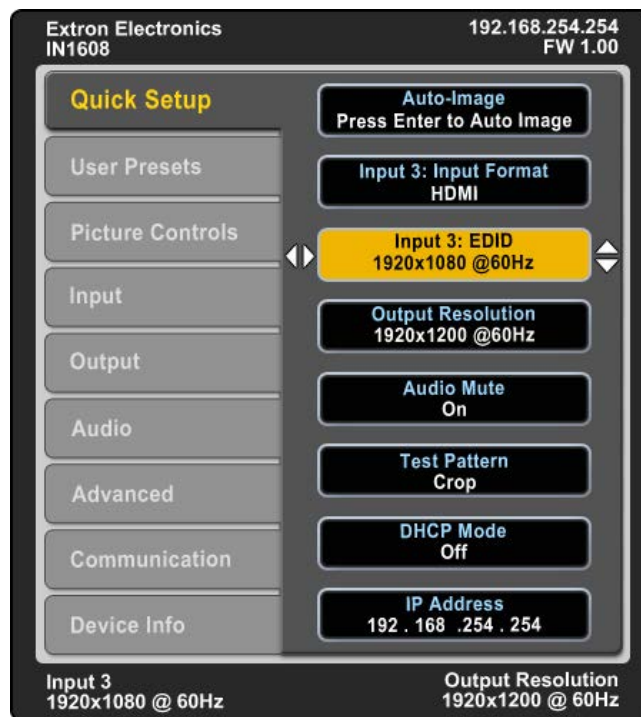

Figure 21. Quick Setup Submenu (IN1608)

The **Quick Setup** submenu provides quick access to common input, output, and communication settings. This submenu contains the following submenu items:

- **Auto-Image** — Press the **Enter** button to automatically size and position the current input (see **Auto-Image** on page 30).
- **Input Format** — Press the navigation buttons to select the desired video input format (see **Input Format** on page 31). The current input is displayed in the title of the submenu.
- **Input EDID** — Press the navigation buttons to select a discrete EDID or match the output resolution (see **EDID** on page 31). The current input is displayed in the title of the submenu.
- **Output Resolution** — Press the navigation buttons to select from a list of output resolutions and refresh rates (see **Resolution** on page 33). There are eight custom options, prefaced by C1 through C8. The default setting is 720p @ 60 Hz.
- **Audio Mute** — Press the navigation buttons to globally mute or unmute the audio.
- **Test Pattern** — Press the navigation buttons to select an available test pattern to display or to turn a test pattern off (see **Test Pattern** on page 36). The available test patterns are **Crop**, **Alternating Pixels**, **Color Bars**, **Grayscale**, **Blue Mode**, and **Audio Test Pattern** (pink noise). The default setting is **Off**.
- **DHCP Mode** — Press the navigation buttons to enable or disable DHCP mode.
- **IP Address** — Press the **Left** and **Right** buttons to change octets. Press the **Up** and **Down** buttons to change the value of a selected octet.

User Presets Submenu



Figure 22. User Presets Submenu (IN1608)

The **User Presets** submenu manages user presets only (input presets are not available through the OSD menu). User presets save the current picture control settings for the selected input for recall later or copy settings to other inputs. There are 16 user presets available per input. Press the **Input Selection** buttons to select an input.

NOTE: If a saved preset is not named, “User Preset XX” is assigned.

From the **Save**, **Recall**, or **Clear** submenu item, press the navigation buttons to select the desired preset to either save picture control settings, recall previously saved picture control settings, or clear a preset of saved settings.

User presets save the following settings:

- Brightness and contrast
- Color and tint
- Detail
- Image size and position
- Preset name

NOTE: To manage input presets, use SIS commands (see [Preset Commands](#) on page 59) or the internal web pages (see [Preset Management Page](#) on page 114).

Picture Controls Submenu

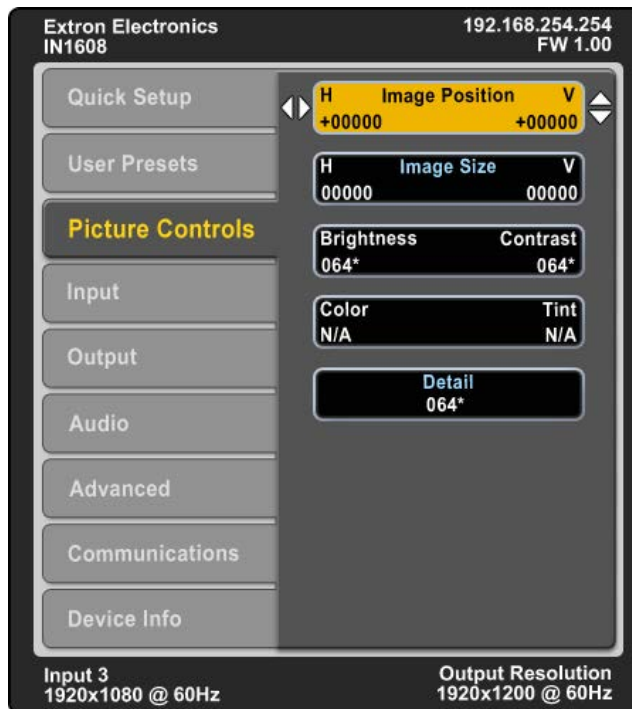

Figure 23. Picture Controls Submenu (IN1608)

The Picture Controls submenu adjusts picture settings.

- **Image Position** — Press the **Left** and **Right** buttons to select the horizontal (H) or vertical (V) position of the image. Press the **Up** and **Down** buttons to adjust the value of the selected position.
- **Image Size** — Press the **Left** and **Right** buttons to select the horizontal (H) or vertical (V) size of the image. Press the **Up** and **Down** buttons to adjust the value of the selected position.
- **Brightness and Contrast** — Press the **Left** and **Right** buttons to select the brightness or contrast of the image. Press the **Up** and **Down** buttons to adjust the value of the selected feature.
- **Color and Tint** — Press the **Left** and **Right** buttons to select the color or tint of the image. Press the **Up** and **Down** buttons to adjust the value of the selected feature. These settings are only applicable to analog NTSC, PAL, and SECAM signals.
- **Detail** — Press the navigation buttons to adjust the detail of the image.

Input Submenu

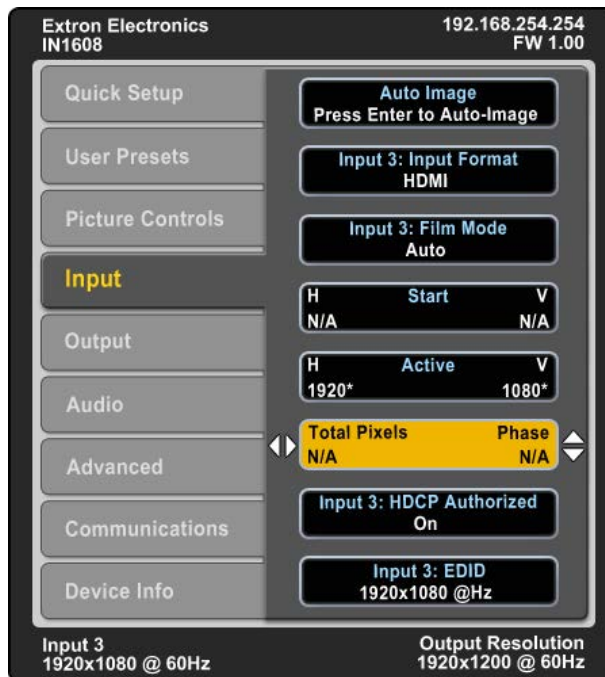

Figure 24. Input Submenu (IN1608)

The Input submenu adjusts the active input.

- **Auto-Image** — Press the **Enter** button to execute an Auto-Image on the active input. Auto-Image updates active pixel, active lines, horizontal and vertical start, phase, horizontal and vertical image position, and horizontal and vertical image size settings.

For analog video sources with dark backgrounds or borders, adjust the Auto-Image threshold with SIS commands (see the **Auto-Image Threshold Value commands** on page 52). Raise the Auto-Image threshold to ignore potential extraneous sync pulses embedded in RGB signals. Lower the threshold to allow for more accurate sizing and centering on dark video sources (such as a dark PC desktop).

The following is performed during an Auto-Image when the aspect ratio is set to Fill:

- Horizontal and vertical image position return to 0.
- Horizontal and vertical image size match the current output resolution.

The following is performed during an Auto-Image when the aspect ratio is set to Follow:

- The horizontal and vertical image position and image size are set to maintain the native aspect of the input rate with regard to the current output resolution.

Set the aspect ratio on the Advanced submenu (see **Aspect Ratio** on page 37).

NOTE: The auto-Image submenu is the same as the standard A SIS command. However, there are other Auto-Image options available through SIS commands (see the **Auto-Image SIS commands** on page 52) or PCS and the internal web pages (see **Signal Sampling panel** on page 93 or **Size and Position Page** on page 97). The options include to execute an Auto-Image and fill the output and to execute an Auto-Image and maintain the input aspect ratio. These commands ignore the current aspect mode setting, auto-image the input, and then apply a “fill” or “follow.”

- **Input Format** — Press the navigation buttons to select an analog video input format for inputs 1 and 2. All other inputs are digital inputs for HDMI or DVI input signals. The following table shows the available formats for each input.

Input 1	Input 2	Input 3	Input 4	Input 5	Input 6	Input 7 (IN1608)	Input 8 (IN1608)
RGB (default)	RGB (default)	HDMI (default)	HDMI (default)	HDMI (default)	HDMI (default)	HDMI (default)	HDMI (default)
YUV	YUV						
RGBcvs	RGBcvs						
S-Video	S-Video						
Composite	Composite						

- **Film Mode** — Press the navigation buttons to turn Film Mode 3:2 and 2:2 detection on (auto detect mode) or off.
- **Start** — Press the **Left** and **Right** buttons to select the horizontal (H) or vertical (V) pixel start values. Press the **Up** and **Down** buttons to adjust the selected position (analog inputs only).
- **Active** — Press the **Left** and **Right** buttons to select the horizontal (H) or vertical (V) active pixels. Press the **Up** and **Down** buttons to adjust the selected value (analog inputs only).
- **Total Pixels and Phase** — Press the **Left** and **Right** buttons to select either **Total Pixels** or **Phase**. Press the **Up** and **Down** buttons to adjust the selected value (analog inputs only).
- **HDCP Authorized** — Press the navigation buttons to enable or disable the HDCP Authorized feature. This feature determines if a digital input will report as an HDCP authorized sink to a source.

For source devices that require encryption, enable HDCP Authorized. If HDCP Authorized is disabled for sources that require encryption (for example, a Blu-ray player), the output is muted or a warning message is displayed.

Some source devices may encrypt their output even if the source material does not require HDCP encryption, preventing content from being displayed on a non-HDCP compliant display. Disable HDCP Authorized to allow the output of the scaler to remain unencrypted.

- **EDID** — Press the navigation buttons to select an EDID for the active input. Select a discrete EDID from a list of factory-supplied EDID or select **Match Output** to use the output resolution and refresh rate (see **Resolution** on page 33 for a full list of available resolution and refresh rates).

Output Submenu

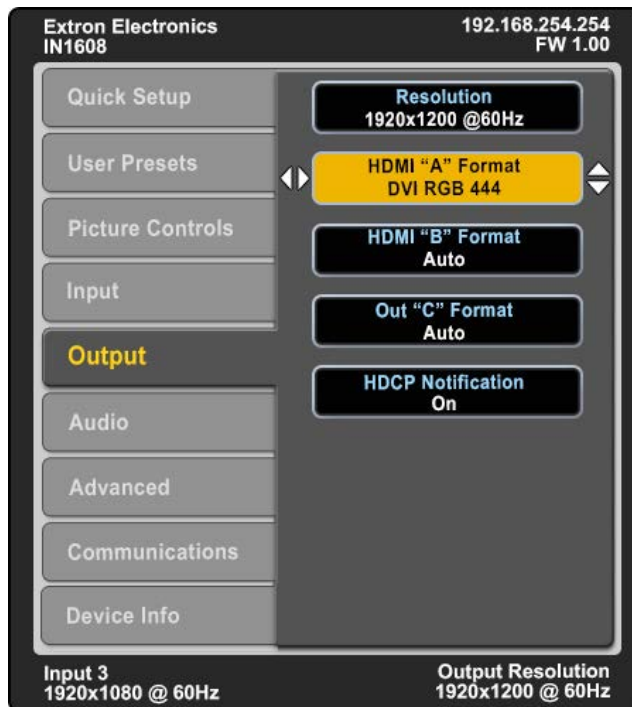

Figure 25. Output Submenu (IN1608)

The Output submenu configures the output resolution, refresh rate, HDMI format, and HDCP notification.

- **Resolution** — Press the navigation buttons to change the resolution and refresh rate from the select list. The following table shows the available resolution and refresh rates.

Resolution	23.98 Hz	24 Hz	25 Hz	29.97 Hz	30 Hz	50 Hz	59.94 Hz	60 Hz	75 Hz
640x480						X		X	X
800x600						X		X	X
852x480						X		X	X
1024x768						X		X	X
1024x852						X		X	X
1024x1024						X		X	X
1280x768						X		X	X
1280x800						X		X	X
1280x1024						X		X	X
1360x765						X		X	X
1360x768						X		X	X
1365x768						X		X	X
1366x768						X		X	X
1365x1024						X		X	X
1440x900						X		X	X
1400x1050						X		X	
1600x900						X		X	
1680x1050						X		X	
1600x1200						X		X	
1920x1200						X		X	
480p							X	X	
576p						X			
720p			X	X	X	X	X	X*	
1080i						X	X	X	
1080p	X	X	X	X	X	X	X	X	
2K (2048x1080)	X	X	X	X	X	X	X	X	
Custom 1 through 8	For captured or uploaded EDID tables								

* Default

NOTE: The eight custom, user-defined output rates default to 720p @ 60 Hz when no custom EDID is captured or uploaded.

- **HDMI or TP Output Format** — After selecting **HDMI “A” Format**, **HDMI “B” Format**, **Out “C” Format** from the list of submenu items, press the navigation buttons to set the output format. HDMI output format has three components:
 - **Video format** — DVI or HDMI
 - **Color space** — RGB 4:4:4, YUV 4:2:2, or YUV 4:4:4
 - **Quantization range** — full (0-255) or limited (16-235)
 The following formats are available:
 - Auto (based on display EDID)
 - DVI RGB 444
 - HDMI RGB 444 Full
 - HDMI RGB 444 Limited
 - HDMI YUV 444 Full
 - HDMI YUV 444 Limited
 - HDMI YUV 422 Full
 - HDMI YUV 422 Limited
- **HDCP Notification** — Press the navigation buttons to enable or disable an HDCP compliance notification for when an HDCP-encrypted input is sent to a non-compliant display. If HDCP notification is enabled, the output displays a moving message reading “HDCP Content” on a green screen. If HDCP notification is disabled, the output displays a black or muted screen.

Audio Submenu



Figure 26. Audio Submenu (IN1608)

The Audio submenu allows users to adjust audio settings. Extron recommends using the PCS or the internal web pages for initial audio configuration (see [Audio Configuration Page](#) on page 98 for more audio configuration details and tips).

- **Audio Mute** — Press the navigation buttons to globally mute or unmute audio output.
- **Audio Format** — Press the navigation buttons to select the audio input format. Analog inputs can only be set to **AnaLog** or **None**. All other inputs can accept all audio input formats.

Audio Input Format	Details	Inputs
None	Mutes audio for the selected input. Sets “No Audio” EDID.	All
Analog	Sets the selected input to analog. Sets “No Audio” EDID.	All
LPCM-2Ch	Sets the selected input to LPCM-2Ch audio. Sets 2Ch audio EDID.	3+
Multi-Ch	Sets the selected input to Multi-Ch audio. Sets Multi-Ch audio EDID.	3+
LPCM-2Ch Auto	Sets the selected input to prioritize digital audio. Analog audio is passed when digital is not present. Sets 2Ch audio EDID.	3+
Multi-Ch Auto	Sets the selected input to prioritize digital audio. Analog audio is passed when digital is not present. Sets Multi-Ch audio EDID.	3+

NOTE: Multi-channel audio does not include microphone inputs or audio processing when it is sent to the output. It is also unaffected by volume control.

- **Gain** — Press the navigation buttons to set the gain (in dB) for the active analog or LPCM-2Ch input.
- **Mic/Line Gain and Phantom** — After selecting **Mic/Line 1** or **Mic/Line 2** from the list of submenu items, press the **Left** and **Right** buttons to select the Mic/Line gain or phantom power status. Press the **Up** and **Down** buttons to set the gain (in dB) or enable or disable phantom power for the selected value.
- **Mic/Line Volume** — Press the navigation buttons to set the Mic/Line mix volume (in dB).
- **Program Volume** — Press the navigation buttons to set the Program mix volume (in dB).
- **Output 1/2 Format** — Press the navigation buttons to set the audio output format.

Advanced Submenu

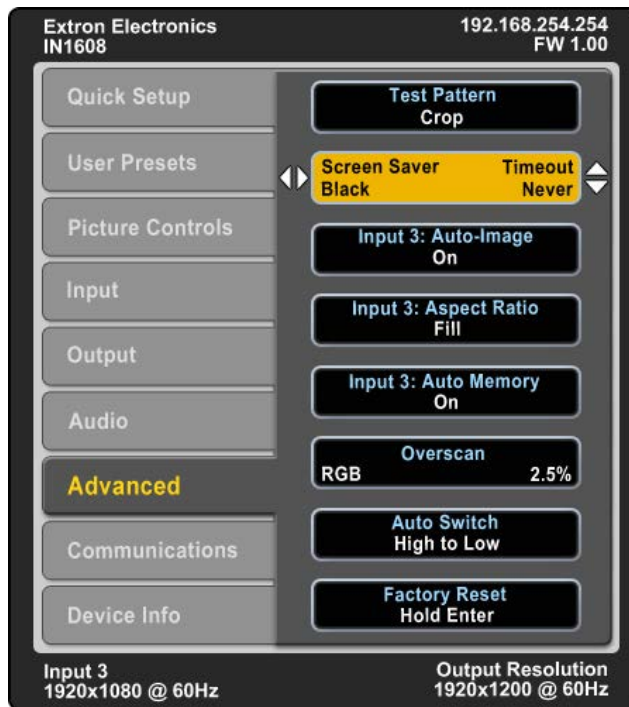

Figure 27. Advanced Submenu (IN1608)

The **Advanced** submenu adjusts of test patterns, screen saver mode, automatic Auto-Image, aspect ratio, auto memory, overscan settings, auto switch, and factory reset.

- **Test Pattern** — Press the navigation buttons to select a test pattern to display or to turn off a test pattern. The available test patterns are Crop, Alternating Pixels, Color Bars, Grayscale, Blue Mode, and Audio Test (pink noise). The default setting is Off.

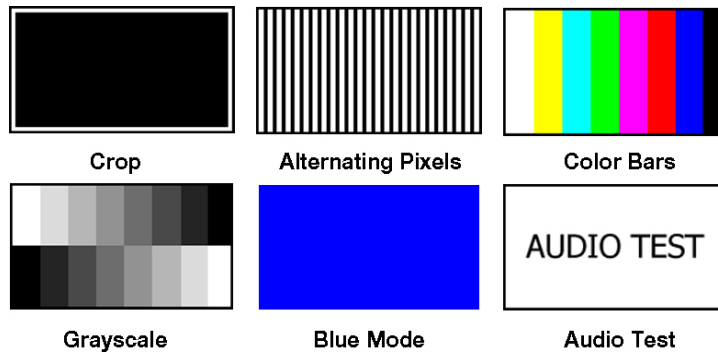

Figure 28. Available Test Patterns

NOTES:

- The audio test outputs pink noise on the embedded digital audio output (2-channel, 48 kHz, 16 bit).
- All test patterns include a single pixel border (except Blue mode).
- All test patterns remain enabled after a power cycle.

- **Screen Saver and Timeout** — Press the **Left** and **Right** buttons to select the screen saver setting or duration the screen saver remains active before sync is disabled. Press the **Up** and **Down** buttons to either set the screen saver to a black (default), blue, or custom color (see **Screen Saver SIS commands** on page 56 to specify a custom color) screen or to set the screen saver time-out duration to a specified number of seconds.

When there is no active video on the selected input, the device can mute the video output to black, blue, or a custom color for a set duration before disabling output sync. By default, the scaler outputs black video and sync (no sync time-out) with no active input applied.

The time-out duration can be set to any duration from 0-500 seconds.

- **Auto-Image** — Press the navigation buttons to turn the automatic per-input Auto-Image mode on or off (default).

When enabled and a new input frequency is detected, the scaler first applies an existing Auto Memory for the signal (if Auto Memory is enabled). If no entry exists, it performs an automatic Auto-Image on the new signal. This sets a size and position for the image to fill the screen, with respect to the current Aspect Ratio setting.

By default, the Auto-Image threshold is 25% brightness. Analog video signals greater than the threshold are considered active video. To change the threshold value, use SIS commands (see the **Auto-Image Threshold Value commands** on page 52).

- **Aspect Ratio** — Press the navigation buttons to set the aspect ratio setting of the active input to Fill (default) or Follow.

When in Fill mode, all inputs automatically fill the entire output. To adjust an aspect ratio for a single input rate, set the desired size and center in the **Picture Controls** submenu (see **Picture Controls Submenu** on page 29). If auto memory is enabled, these settings are saved and recalled the next time the signal is detected.

In Follow mode, each input rate is displayed with its native aspect ratio mode with the correct letter box or pillar box settings visible.

The scaler clears the previous size and position settings whenever the aspect ratio setting for an input is adjusted.

- **Auto Memory** — Press the navigation buttons to turn Auto Memory on or off for each input. The scaler stores 32 auto memories per input, with input configuration and picture control data for each video resolution. The default setting enables these memories to automatically recall input and picture controls for previously applied signals. When auto memories are disabled, the scaler treats every applied signal as a new source.

Auto Memory and Auto-Image Interaction		
Auto Memory	Auto-Image	Information
On	On	“New” signals and rates not previously detected by the scaler, are initially set up using default parameters, then Auto-Image is automatically applied. The next time the signal is detected, the values stored in the auto memory location are applied.
On (default)	Off (default)	“New” signals and rates not been previously detected by the scaler, are set up using default parameters. If manual input or picture settings are made to the input, an auto memory location is created and recalled each time the input is detected.
Off	On	Each change in input sync, input switch, or power cycle triggers an automatic Auto-Image. When auto memory is disabled, each change in sync is treated as a new signal and an automatic Auto-Image is triggered. Manual changes made to the image and picture controls are lost each time a new rate is detected.
Off	Off	Each change in input sync causes default values to be applied. Manual changes made to the image and picture controls are lost when a new rate is applied, a new input is applied, or after a power cycle.

- **Overscan** — Press the navigation buttons to select the overscan value for each input format. Choose between 0%, 2.5%, or 5%. Set default overscan mode through SIS commands (see the [Overscan Mode SIS commands](#) on page 61).

Overscan is specific to each input signal type. This feature zooms and crops SMPTE input resolutions to mask edge effects and ancillary data that are common in broadcast signals. When the overscan mode is not at 0%, an Auto-Image on a SMPTE input rate (NTSC, PAL, SECAM, 480p, 576p, 720p, 1080i, 1080p, and 2K [2048x1080]) refers to the default input lookup table values instead of performing a “true” auto image.

NOTE: Overscan is valid only on SMPTE input rates (NTSC, PAL, 480p, 576p, 720p, 1080i, 1080p, or 2K [2048x1080]) and is global for each video format.

- **Auto Switch** — Press the navigation buttons to turn the auto switch mode on or off, and to set the priority. The auto switch setting allows for basic, unmanaged, input switching based on the presence of active input signals. Auto switch mode options are:
 - Disabled (off)
 - Setting priority to “high to low” (highest numbered active input to the lowest)
 - Setting priority to “low to high” (lowest numbered active input to the highest)
- **Factory Reset** — Press and hold the **Enter** button to reset the device to factory defaults. The scaler retains the current firmware version, as well as communication and IP settings.

Communication Submenu

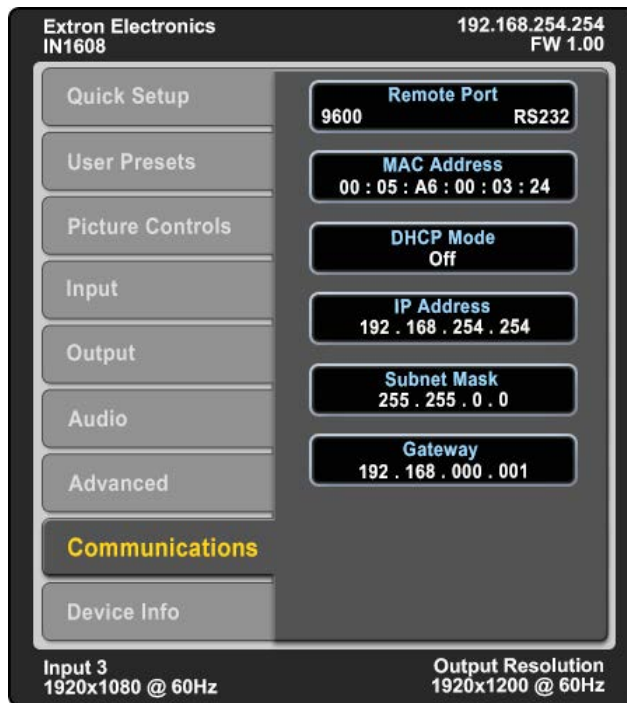

Figure 29. Communication Submenu (IN1608)

The **Communication** submenu displays RS-232 settings, current IP configuration (DHCP mode, IP address, Subnet mask, and Gateway address), and MAC address.

Press and hold the **Enter** button for 10 seconds to edit the submenu items listed below.

- **Remote Port** — Displays the baud rate for the serial RS-232.
- **MAC Address** — Displays the MAC address of the device (read only).
- **DHCP Mode** — Press the navigation buttons to turn the DHCP mode on or off. The default is **Off**.
- **IP Address** — Press the **Left** and **Right** buttons to select an octet of the IP address. Press the **Up** and **Down** buttons to adjust the value of the selected octet. The default is 192.168.254.254.
- **Subnet Mask** — Press the **Left** and **Right** buttons to select an octet of the subnet mask address. Press the **Up** and **Down** buttons to adjust the value of the selected octet. The default is 255.255.0.0.
- **Gateway** — Press the **Left** and **Right** buttons to select an octet of the gateway address. Press the **Up** and **Down** buttons to adjust the value of the selected octet. The default is 0.0.0.0.

Device Info Submenu

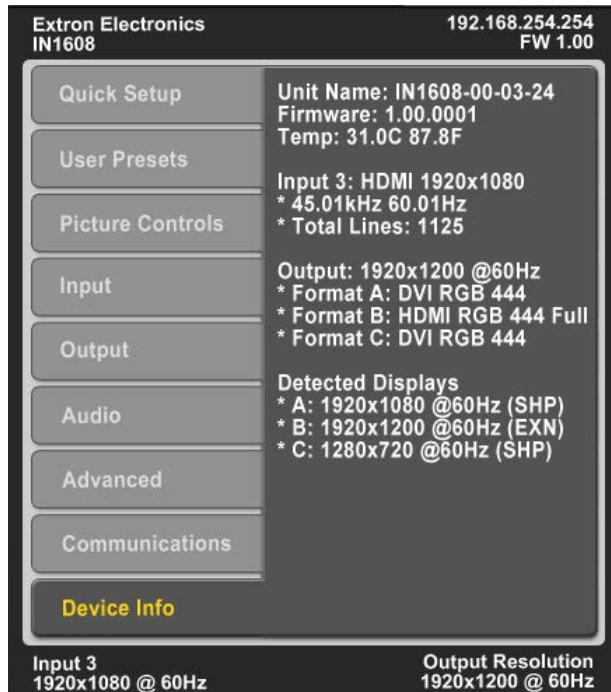

Figure 30. Device Info Submenu (IN1608)

The **Device Info** submenu displays device information including unit name, firmware version, internal temperature, input and output signal information, and detected display information. This submenu does not contain any adjustable submenu items.

Front Panel Lockout (Executive Modes)

The scalers have three modes of front panel security lock that limit the operation of the device from the front panel.

- **Front Panel Lockout mode 0 (disabled)** — Unlocks front panel functions. This is the default setting.
- **Front Panel Lockout mode 1 (enabled)** — Locks all front panel functions completely. This mode can be enabled or disabled only by SIS commands (see the **Front Panel Lockout Mode commands** on page 60). All functions can still be performed through USB, RS-232, or Ethernet control (see **SIS Configuration and Control** beginning on page 42, **Configuration Software** beginning on page 67, or **Internal Web Pages** beginning on page 85).
- **Front Panel Lockout mode 2 (enabled)** — Locks all front panel functions except input switching and volume control. All functions and adjustments can still be made through USB, RS-232, or Ethernet control (see **SIS Configuration and Control**, **Configuration Software**, or **Internal Web Pages**).

To enable executive mode 2, press and hold the **Menu** and **Enter** buttons simultaneously for 3 seconds.

The menu system returns to the default menu within 10 seconds.

Reset Modes

There are three reset modes (numbered 1, 4, and 5). These are available by pressing the recessed **Reset** button on the rear panel (see **A** in the image to the right). See the following table for a summary of the reset modes.

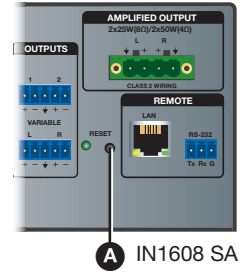

ATTENTION:

- Review the reset modes carefully. Using the wrong reset mode may result in unintended loss of flash memory programming, port reassignment, or processor reboot.
- Étudier de près les différents modes de réinitialisation. Appliquer le mauvais mode de réinitialisation peut causer une perte inattendue de la programmation de la mémoire flash, une reconfiguration des ports ou une réinitialisation du processeur.

NOTE: The reset modes listed close all open IP and Telnet connections and all sockets. Each mode is a separate function, not a continuation from mode 1 to mode 5.

Reset Modes Summary			
Mode	Activation	Result	Purpose/Notes
Use Factory Firmware	<p>1 Hold in the recessed Reset button for 30 seconds while applying power to the scaler.</p> <div style="border: 1px solid black; padding: 5px;"> <p>NOTE: After a mode 1 reset, update the device with the latest firmware version. DO NOT operate with the firmware version that results from this mode reset. This temporarily resets the device to factory default until power is recycled. To use factory default firmware, upload that version again.</p> </div>	<p>The device reverts to the factory default firmware.</p> <ul style="list-style-type: none"> Firmware reverts to the factory default for a single power cycle. All user files and settings (drivers, audio and video adjustments, IP settings, and so on) are maintained. <div style="border: 1px solid black; padding: 5px;"> <p>NOTE: If you do not want to update the firmware or perform a mode 1 reset by mistake, cycle power to the device to return to the firmware version running prior to the reset.</p> </div>	Use mode 1 to revert to the factory default version if incompatibility issues arise with user-loaded firmware.
Reset IP Settings	<p>4 Hold down the Reset button until the Reset LED blinks twice (approximately 6 seconds). Then, press Reset momentarily (<1 second).</p>	<p>IP settings revert to factory defaults.</p> <ul style="list-style-type: none"> Port mapping reverts to factory default. DHCP turns off. IP address is set to 192.168.254.254. Reset LED blinks four times in quick succession during reset. 	Use mode 4 to reset all IP settings back to factory defaults.
Reset to Factory Default	<p>5 Hold down the Reset button until the Power LED blinks 3 times (approximately 9 seconds). Then, press Reset momentarily (<1 second).</p>	<p>The device reverts to the factory defaults except for firmware.</p> <ul style="list-style-type: none"> Mode 4 results are performed. All user modifiable configurations reset to default values including IP settings and real-time adjustments. All user loaded files are deleted. The Reset LED blinks 4 times in quick succession during the reset. 	<p>Use mode 5 to restart with default configuration.</p> <div style="border: 1px solid black; padding: 5px;"> <p>NOTE: This reset, equivalent to the [Esc]ZQQQ← SIS command, also removes the initial serial number passwords and sets them to no password.</p> </div>

SIS Configuration and Control

The scaler can be configured and controlled with Extron Simple Instruction Set commands when connected to a host computer or other device (such as a control system). Attach the host device to the rear panel RS-232 connector, the LAN port, or the front panel USB port. Commands can be entered using a Telnet application such as the Extron DataViewer, available at www.extron.com (see the *DataViewer Help* file for more details). This section describes SIS communication and control. Topics in this section include:

- [Host and Scaler Communication](#)
- [Using the Command and Response Tables](#)
- [Symbol Definitions](#)
- [Command and Response Tables](#)

The scaler uses a protocol of 9600 baud, 1 stop bit, no parity, and no flow control (see [Remote RS-232 Connector](#) on page 18).

Host and Scaler Communication

SIS commands consist of one or more characters per field. No special characters are required to begin or end a command sequence. When the scaler determines that a command is valid, it executes the command and sends a response to the host device. All responses from the scaler to the host end with a carriage return and a line feed (CR/LF = `↵`), indicating the end of the response character string (one or more characters).

Scaler-Initiated Messages

When a local event such as a front panel selection or adjustment takes place, the scaler responds by sending a message to the host. No response is required from the host. Example scaler-initiated messages are listed here.

- In `[x1] All↵` (where `[x1]` is the input number during an input switch).
- `Reconfig↵` The scaler sends this response when an input is switched or when a new signal is detected.
- `Hp1g0[x2]↵` The scaler sends this response when a hot plug event on output `[x2]` is detected.

Copyright Information

The copyright message is displayed upon connecting to a scaler via TCP/IP or Telnet or after a power cycle via RS-232 and depends on the scaler model.

```
↵ © Copyright YYYY, Extron Electronics, [model], Vx.xx, 60-XXXX-XX↵  
Ddd, DD MMM YYYY HH:MM:SS ↵ (day, date, and time as in Mon, 18 May 2015  
11:27:33)
```

Vx.xx is the firmware version number.

60-XXXX-XX is the model part number.

YYYY is the year.

Password Messages

The **←Password:** prompt is displayed after the copyright messages and requires a password (administrator level or user level) followed by a carriage return.

NOTES:

- The factory configured passwords for all accounts on these devices have been set to the device serial number. Passwords are case sensitive.
- Performing a unit factory reset (entering an **Esc Z000← SIS command** [see page 63] or a **mode 5 reset** via the rear panel **Reset** button [see page 41]) resets the serial number passwords to no password.

If the correct password is entered, the unit responds with **←Login Administrator←** or **←Login User←**, depending on the password entered. If passwords are the same for both administrator and user, the switcher defaults to administrator privileges.

NOTE: The password prompt is redisplayed if an incorrect password is entered.

Error Responses

When the scaler receives a valid command, it executes the command and sends a response to the host device. If the unit is unable to execute the command, it returns an error response to the host.

Error codes

E01 — Invalid input number

E06 — Invalid input channel change

NOTE: Auto-Switch mode is active.

E10 — Invalid command

E11 — Invalid preset number

E12 — Invalid port number

E13 — Invalid parameter

E14 — Not valid for this configuration

E17 — Invalid command for signal type

E22 — Busy

E24 — Privilege violation

E25 — Device not present

E26 — Maximum number of connections exceeded

E28 — Bad filename or file not found

Error response references

These references in the command and response tables note particular error responses to that command.

¹⁴ = Commands that give an E14 (invalid command for this configuration) error if sent to a product whose current configuration does not support the command

²⁴ = Commands that give an E24 (privilege violation) error if not administrator level

²⁸ = Commands that may give an E28 (file not found) error

Using the Command and Response Tables

The **Command and Response Table** for SIS commands beginning on page 50 lists the commands that the scaler recognizes as valid, the responses that are returned to the host, a description of the command function or the results of executing the command, and examples of commands in ASCII (Telnet) and URL encoded (web).

ASCII to Hex Conversion Table																Esc	1B	CR	ØD	LF	ØA
Space →	20	!	21	"	22	#	23	\$	24	%	25	&	26	'	27						
(28)	29	*	2A	+	2B	,	2C	-	2D	.	2E	/	2F						
Ø	30	1	31	2	32	3	33	4	34	5	35	6	36	7	37						
8	38	9	39	:	3A	;	3B	<	3C	=	3D	>	3E	?	3F						
@	40	A	41	B	42	C	43	D	44	E	45	F	46	G	47						
H	48	I	49	J	4A	K	4B	L	4C	M	4D	N	4E	O	4F						
P	50	Q	51	R	52	S	53	T	54	U	55	V	56	W	57						
X	58	Y	59	Z	5A	[5B	\	5C]	5D	^	5E	_	5F						
`	60	a	61	b	62	c	63	d	64	e	65	f	66	g	67						
h	68	i	69	j	6A	k	6B	l	6C	m	6D	n	6E	o	6F						
p	70	q	71	r	72	s	73	t	74	u	75	v	76	w	77						
x	78	y	79	z	7A	{	7B		7C	}	7D	~	7E	DEL	7F						

Figure 31. ASCII to Hexadecimal Character Conversion Table

Symbol Definitions

- = Space
- ↵ = Carriage return with line feed
- ← = Carriage return with no line feed (for URL-encoded commands, use the pipe character, |, instead)
- | = Pipe (vertical bar) character
- Esc** = Escape key (for URL-encoded commands, use W instead)
- ^{14, 24, 28} = Superscripts indicate the error message displayed if the command is entered incorrectly or with invalid parameters (see **Error response references** on the previous page).
- X1** = Input selection
 - 1 - 6 (IN1606)
 - 1 - 8 (IN1608 Series)
- X2** = Output selection
 - 1 = HDMI A (top connector)
 - 2 = HDMI B (bottom connector)
 - 3 = Out C
- X3** = Input video format
 - 1 = RGB (default for inputs 1 and 2)
 - 2 = YUV
 - 3 = RGBcvS
 - 4 = S-video
 - 5 = Composite
 - 6 = HDMI (default for inputs 3 and higher)
- X4** = Horizontal or vertical start
 - Ø-255 (default midpoint of 128 translates to the default value in the input lookup tables)
- X5** = Pixel phase
 - Ø-63 (31 = default)
- X6** = Total pixels
 - ±512 of the default value
- X7** = Active pixels
 - ±512 of the default value
- X8** = Active lines
 - ±512 of the default value
- X9** = Enable or disable
 - Ø = off or disabled
 - 1 = on or enabled

X10	= Input standard	0 = no signal detected on the current input 1 = NTSC 3.85 2 = PAL 3 = NTSC 4.43 4 = SECAM - = N/A (occurs when the input is active RGB, YUV, or HDMI signal)
X11	= Internal temperature	In degrees Celsius
X12	= Film detect mode	0 = disabled 1 = auto (default)
X13	= Horizontal and vertical frequencies	xxx.x
X14	= Text label	Up to 63 characters
X15	= Picture adjustment	0-127 (64 = default)
X16	= Horizontal position	±2048
X17	= Vertical position	±1200
X18	= Horizontal size	10-04096
X19	= Vertical size	10-02400
X20	= Test patterns	0 = off (default) 1 = crop 2 = alternating pixels 3 = color bars 4 = grayscale 5 = blue mode 6 = audio test pattern (pink noise)
X21	= User presets	01-16
X22	= Input presets	1-128
X23	= On-screen display bug time-out Output sync time-out	0 = OSD is never displayed, output sync is instantly disabled with no active input 1-500 = 1 second increments 3 = OSD bug time-out default 501 = OSD bug never times out, output sync never times out
X24	= Executive mode status	0 = off or disabled (default) 1 = mode 1 (complete front panel lockout) 2 = mode 2 (only allow input switching and volume control)
X25	= Overscan	0 = 0.0% (default for RGB, HDMI) 1 = 2.5% (default for RGBcvS, YUV, S-video, and CV) 2 = 5.0%
X26	= Aspect ratio setting	1 = fill (default) 2 = follow
X27	= Screen saver mode	0 = custom color 1 = black output (default) 2 = blue output
X28	= Custom screen saver color	000000 (black) to FFFFFFFF (white) in HTML style hexadecimal values (for example, FF0000 = red, 00FF00 = green, and 0000FF = blue)

X29	= Video output mute	<ul style="list-style-type: none"> 0 = unmute 1 = mute video 2 = mute video and sync
X30	= Auto-Image threshold value	<ul style="list-style-type: none"> 0-100 (where 0 = black and 100 = white; 025 = default)
X31	= HDCP status	<ul style="list-style-type: none"> 0 = no sink or source device detected 1 = sink or source detected with HDCP 2 = sink or source detected but no HDCP
X32	= Video switching effect	<ul style="list-style-type: none"> 0 = cut 1 = fade through black (default)
X33	= HDMI output format	<ul style="list-style-type: none"> 0 = auto (based on the display EDID: default) 1 = DVI RGB 444 2 = HDMI RGB 444 "Full" 3 = HDMI RGB 444 "Limited" 4 = HDMI YUV 444 "Full" 5 = HDMI YUV 444 "Limited" 6 = HDMI YUV 422 "Full" 7 = HDMI YUV 422 "Limited"
X34	= Default name	A combination of model name and the last three pairs of the device MAC address (for example, IN1606-07-8C-EC)
X35	= Audio input format	<ul style="list-style-type: none"> 0 = none (input muted) 1 = analog (default for inputs 1 and 2) 2 = LPCM-2Ch digital (default for inputs 3 and higher) 3 = Multi-Ch digital 4 = LPCM-2Ch digital auto 5 = Multi-Ch digital auto
X36	= Video signal status	<ul style="list-style-type: none"> 0 = video or HDMI signal not detected 1 = video or HDMI signal detected
X37	= Power save mode	<ul style="list-style-type: none"> 0 = full power mode (default) 1 = lower power state
X38	= Screen saver status	<ul style="list-style-type: none"> 0 = active input detected, timer not running 1 = no active input, timer running, output sync still active 2 = no active input, timer expired, output sync disabled
X39	= HDCP authorization status	<ul style="list-style-type: none"> 0 = block HDCP encryption 1 = allow HDCP encryption (default)
X40	= IP address	<ul style="list-style-type: none"> xxx.xxx.xxx.xxx (192.168.254.254 = default)
X41	= Subnet mask	<ul style="list-style-type: none"> xxx.xxx.xxx.xxx (255.255.0.0 = default)
X42	= Gateway address	<ul style="list-style-type: none"> xxx.xxx.xxx.xxx (0.0.0.0 = default)
X43	= MAC address	<ul style="list-style-type: none"> 00-05-A6-xx-xx-xx
X44	= Number of open connections	<ul style="list-style-type: none"> 0-<maximum number of open connections>
X45	= Config type	<ul style="list-style-type: none"> 0 = IP config 1 = device-specific parameters

X46	= Volume group number	1 = program volume 3 = mic volume 8 = variable volume
X47	= Group volume level	-1000 to 0, where -1000 = -100 dB or 0% volume and 0 = 0 dB or 100% volume
X48	= Mute group number	2 = program mute 4 = mic mute 7 = output mute
X49	= Bass and treble group number	5 = bass control 6 = treble control
X50	= Bass and treble level	-240 to +120, where -240 = -24 dB and +120 = 12 dB
X51	= Increment value	dB value multiplied by ten, in 0.1 dB increments, to raise or lower a group fader (for example, 100 = 10 dB)
X52	= Password	0 to 128 characters can be used for admin or user passwords.

NOTES:

- / \ | * and *space* are invalid in passwords.
- The factory configured passwords for all accounts on this device have been set to the device serial number. Passwords are case sensitive.
- In the event of a reset to factory defaults (**Esc** ZQQQ← SIS command), the passwords are set to no password.

X53	= Verbose mode	0 = clear or none (default for Telnet connections) 1 = verbose mode (default for RS-232) 2 = tagged responses for queries 3 = verbose mode and tagged for queries
X54	= Auto switch mode	0 = disable (default) 1 = prioritizes the highest numbered active input 2 = prioritizes the lowest numbered active input
X55	= Video mute on all outputs	0 = all outputs are unmuted 1 = at least one output is muted 2 = at least one output is muted and sync is disabled
X56	= Volume knob group number	1 = program volume (default) 3 = mic volume 8 = output volume

X57 = Gain or mute control

40100 = mic 1 (mix volume only)
40000 = mic 1 (mute only)
40101 = mic 2 (mix volume only)
40001 = mic 2 (mute only)
60000 = output 1
60002 = output 2
60004 = variable output L
60005 = variable output R
60006 = digital output L
60007 = digital output R
60008 = amplified output L (stereo models) or
amplified output (mono models)
60009 = amplified output R (stereo models)

X58 = Gain or trim level

-1000 to 0 = dB value multiplied by ten, in 0.1
dB increments, (for example, -100 = -10 dB)
0 = default

X59 = HDCP mode

0 = encrypts the output only when required by
the selected input source (default)
1 = always encrypts the output, regardless of
the HDCP status of the selected input
source
2 = encrypts the output only when required by
the selected input source. Use this setting
when DVI sink devices initially pass HDCP
encrypted content, but intermittently display
a green HDCP notification screen after a
power cycle or resuming from sleep mode.
3 = always encrypts the output regardless of
the
HDCP status of the selected input source.
Use this setting when DVI sink devices
initially pass HDCP encrypted content, but
intermittently display a green HDCP
notification screen after a power cycle or
resuming from sleep mode.
4 = prevents HDCP encryption and
authentication.

x60 = EDID emulation or output rate

∅ = automatic (matches the current output resolution; default for EDID emulation only)
 1 = output A (available for EDID export only)
 2 = output B (available for EDID export only)
 3 = custom EDID or output rate 1
 4 = custom EDID or output rate 2
 5 = custom EDID or output rate 3
 6 = custom EDID/output rate 4
 7 = custom EDID/output rate 5
 8 = custom EDID/output rate 6
 9 = output C (available for EDID export only; IN1608 Series)
 2∅1 = custom EDID/output rate 7
 2∅2 = custom EDID/output rate 8

SIS Variables for EDID Resolution and Refresh Rate Combinations (where x60 = 10-92)									
Resolution	23.98 Hz	24 Hz	25 Hz	29.97 Hz	30 Hz	50 Hz	59.94 Hz	60 Hz	75 Hz
640x480						1∅		11	12
800x600						13		14	15
852x480						16		17	18
1024x768						19		2∅	21
1024x852						22		23	24
1024x1024						25		26	27
1280x768						28		29	3∅
1280x800						31		32	33
1280x1024						34		35	36
1360x765						37		38	39
1360x768						4∅		41	42
1365x768						43		44	45
1366x768						46		47	48
1365x1024						49		5∅	51
1440x900						52		53	54
1400x1050						55		56	
1600x900						57		58	
1680x1050						59		6∅	
1600x1200						61		62	
1920x1200						63		64	
480p							65	66	
576p						67			
720p			68	69	7∅	71	72	73*	
1080i						74	75	76	
1080p	77	78	79	8∅	81	82	83	84	
2048x1080 (2K)	85	86	87	88	89	9∅	91	92	

* = Default output resolution

Command and Response Table

Command	ASCII Command (Host to Scaler)	Response (Scaler to Host)	Additional Description
Input Switching Commands			
Input Selection			
Video and audio	[X1]!	In[X1]●All↵	Select video and audio from input [X1].
Video only	[X1]&	In[X1]●RGB↵	Select video-only from input [X1].
Audio only	[X1]\$	In[X1]●Aud↵	Select audio-only from input [X1].
View video input	&	[X1]↵	View the current video input.
View audio input	\$	[X1]↵	View the current audio input.
View current input	!	[X1]↵	View the current video and audio input.
NOTES:			
<ul style="list-style-type: none"> • Audio breakaway (\$) is not allowed to an input configured for any digital audio format. • Video breakaway (&) is not allowed from an input configured for any digital audio format. • Attempting either of these invalid modes gives an E17 error. • Audio breakaway is always allowed back to the current video input. 			
Auto Switch Mode			
Disable auto switch mode	[Esc]ØAUSW↵	AuswØ↵	Manual input switching only (default).
Prioritize highest active input	[Esc]1AUSW↵	Ausw1↵	Automatically switches to the highest numbered active input.
Prioritize lowest active input	[Esc]2AUSW↵	Ausw2↵	Automatically switches to the lowest numbered active input.
View auto switch mode	[Esc]AUSW↵	[X54]↵	View the current auto switch mode.
KEY:			
[X1] = Input selection		1 - 6 (IN1606) or 1 - 8 (IN1608 Series)	
[X54] = Auto switch mode		Ø = disable (default)	
		1 = gives priority to the highest numbered active input	
		2 = gives priority to the lowest numbered active input	

Command	ASCII Command (Host to Scaler)	Response (Scaler to Host)	Additional Description
Input Configuration Commands			
Input Video Format			
Set video format	[X1]*[X3] \	Typ [X1]*[X3] ↵	Set input [X1] to format [X3] .
View set format	[X1] \	[X3] ↵	View the video format.
Input EDID			
Assign EDID to input	[Esc]A[X1]*[X60] EDID ←	EdidA [X1]*[X60] ↵	Assign EDID [X60] to input [X1] .
View assigned EDID	[Esc]A[X1] EDID ←	[X60] ↵	View the EDID for input [X1] .
Save an output EDID to custom slot	[Esc]S[X2]*[X60] EDID ←	EdidS [X2]*[X60] ↵	Save output [X2] EDID to [X60] (3-8, 201, 202).
Export EDID file	[Esc]E[X60],<filename> EDID ←	EdidE [X60] ↵	Export [X60] (1-92, 201, 202) EDID.
Import EDID file	[Esc]I[X60],<filename> EDID ←	EdidI [X60] ↵	Import [X60] (3-8, 201, 202) EDID.
NOTES:			
<ul style="list-style-type: none"> EDID import and export commands use the device user file system to hold an EDID file. Use IP Link File Manager (download IP Link File Manager from the Extron website) to move EDID files between a PC and the device user file system. <filename> can optionally carry a full path name on the device user file system. EDID files must have a file extension of .bin, carrying 128 or 256 bytes of binary data. Exporting a default EDID table (for an [X59] value of 10 or greater) results in the HDMI LPCM-2Ch table being exported. 			
Input Name			
Write input name	[Esc][X1],[X14] NI ←	Nmi [X1],[X14] ↵	Rename input [X1] .
View input name	[Esc][X1] NI ←	[X14] ↵	View the name of input [X1] .
NOTE: To clear an input name, enter a single space character for [X14] . This resets the input name to the default.			
KEY:			
[X1] = Input selection		1 - 6 (IN1606) or 1 - 8 (IN1608 Series)	
[X2] = Output selection		1 = HDMI A (top connector) 2 = HDMI B (bottom connector) 3 = Out C	
[X3] = Input video format		1 = RGB (default for inputs 1 and 2) 2 = YUV 3 = RGBcvS 4 = S-video 5 = composite 6 = HDMI (default for inputs 3 and higher)	
[X14] = Input name (text label)		Up to 16 characters	
[X60] = EDID emulation		See the [X60] definition on page 49.	

Command	ASCII Command (Host to Scaler)	Response (Scaler to Host)	Additional Description
Input Configuration Commands (continued)			
Auto-Image			
Enable	[X1]*1A	Img[X1]*1↵	Activate Auto-Image for input [X1].
Disable	[X1]*ØA	Img[X1]*Ø↵	Turn off Auto-Image for input [X1].
View	[X1]A	[X9]↵	View the Auto-Image setting for input [X1].
Execute	A	ImgØ↵	Execute an Auto-Image for the current input (follows the aspect ratio of the current input).
Execute and fill	1*A	Img1↵	Execute an Auto-Image and fill the entire output.
Execute and follow	2*A	Img2↵	Execute an Auto-Image and maintain the aspect ratio of the current input.
Auto-Image Threshold Value (luminosity value which the scaler defines as active video for Auto-Image)			
Set value	[Esc][X30]ALVL↵	A1vl[X30]↵	Set the global Auto-Image luminosity to [X30].
View	[Esc]ALVL↵	[X30]↵	View the global Auto-Image luminosity setting.
Horizontal Start			
Specify a value	[Esc][X4]HSRT↵	Hsrt[X1]*[X4]↵	Set the horizontal start position.
Increment value	[Esc]+HSRT↵	Hsrt[X1]*[X4]↵	Increase the horizontal start position by one.
Decrement value	[Esc]-HSRT↵	Hsrt[X1]*[X4]↵	Decrease the horizontal start position by one.
View	[Esc]HSRT↵	[X4]↵	View the horizontal start position.
Vertical Start			
Specify a value	[Esc][X4]VSRT↵	Vsrt[X1]*[X4]↵	Set the vertical start position.
Increment value	[Esc]+VSRT↵	Vsrt[X1]*[X4]↵	Increase the vertical start position by one.
Decrement value	[Esc]-VSRT↵	Vsrt[X1]*[X4]↵	Decrease the vertical start position by one.
View	[Esc]VSRT↵	[X4]↵	View the vertical start position.
KEY:			
[X1] = Input selection		1 - 6 (IN1606) or 1 - 8 (IN1608 Series)	
[X4] = Horizontal and vertical start		Ø - 255 (128 = default)	
[X9] = Enable or disable		Ø = off or disabled, 1 = on or enabled	
[X30] = Auto-Image threshold value		Ø - 1ØØ (where Ø = black and 1ØØ = white; 25 = default)	

Command	ASCII Command (Host to Scaler)	Response (Scaler to Host)	Additional Description
Input Configuration Commands (continued)			
Pixel Phase (available only for RGB and YUV-HD input signals)			
Specify a value	Esc X5 PHAS ←	Phas X1 * X5 ↵	Set the pixel phase to X5 on the current input.
Increment value	Esc +PHAS ←	Phas X1 * X5 ↵	Increase the pixel phase by one on the current input.
Decrement value	Esc -PHAS ←	Phas X1 * X5 ↵	Decrease the pixel phase by one on the current input.
View	Esc PHAS ←	X5 ↵	View the pixel phase setting on the current input.
Total Pixels (available only for RGB and YUV-HD input signals)			
Specify a value	Esc X6 TPIX ←	Tpix X1 * X6 ↵	Set the total pixels to X6 on the current input.
Increment value	Esc +TPIX ←	Tpix X1 * X6 ↵	Increase the total pixels by one on the current input.
Decrement value	Esc -TPIX ←	Tpix X1 * X6 ↵	Decrease the total pixels by one on the current input.
View	Esc TPIX ←	X6 ↵	View the total pixel setting on the current input.
Active Pixels			
Specify a value	Esc X7 APIX ←	Apix X1 * X7 ↵	Set the active pixels to X7 on the current input.
Increment value	Esc +APIX ←	Apix X1 * X7 ↵	Increase the active pixels by one on the current input.
Decrement value	Esc -APIX ←	Apix X1 * X7 ↵	Decrease the active pixels by one on the current input.
View	Esc APIX ←	X7 ↵	View the active pixel setting on the current input.
Active Lines			
Specify a value	Esc X8 ALIN ←	Alin X1 * X8 ↵	Set the active lines to X8 on the current input.
Increment value	Esc +ALIN ←	Alin X1 * X8 ↵	Increase the active lines by one on the current input.
Decrement value	Esc -ALIN ←	Alin X1 * X8 ↵	Decrease the active lines by one on the current input.
View	Esc ALIN ←	X8 ↵	View the active lines setting on the current input.
3:2, 2:2, 24:1 Film Mode Detect			
Auto	Esc X1 *1FILM ←	Film X1 * X12 ↵	Set film mode detection to automatic (default).
Off	Esc X1 *ØFILM ←	Film X1 * X12 ↵	Disable film mode detection.
View setting	Esc X1 FILM ←	X12 ↵	View the current film mode setting.
KEY:			
X1 = Input selection		1 - 6 (IN1606) or 1 - 8 (IN1608 Series)	
X5 = Pixel phase		Ø - 63 (31 = default)	
X6 = Total pixels		±512 of the default value	
X7 = Active pixels		±512 of the default value	
X8 = Active lines		±512 of the default value	
X12 = Film detect mode		Ø = disabled 1 = auto (default)	

Command	ASCII Command (Host to Scaler)	Response (Scaler to Host)	Additional Description
Picture Adjustment Commands			
Video Mute for Individual Outputs (defaults to unmuted after a power cycle)			
Set video mute for an individual output	[X2]*[X29]B	Vmt[X2]*[X29]←	Mute the video or the video and sync, or unmute output [X2] only.
View output mute status	[X2]*B	[X29]←	View the mute status of output [X2].
Video Mute for All Outputs (defaults to unmuted after a power cycle)			
Mute video to black	1B	Vmt1←	Mute video to black on all outputs.
Mute sync and video	2B	Vmt2←	Mute video and sync on all outputs.
Unmute sync and video	ØB	VmtØ←	Unmute all outputs.
View mute status on all outputs	B	[X55]←	View the mute status on all outputs.
Color (NTSC, PAL, and SECAM inputs only)			
Specify a value	[Esc][X15]COLR←	Co1r[X1]*[X15]←	Set the color level on the current input.
Increment value	[Esc]+COLR←	Co1r[X1]*[X15]←	Increase the color level by one.
Decrement value	[Esc]-COLR←	Co1r[X1]*[X15]←	Decrease the color level by one.
View	[Esc]COLR←	[X15]←	View the color level setting.
Tint (NTSC inputs only)			
Specify a value	[Esc][X15]TINT←	Tint[X1]*[X15]←	Set the tint on the current input.
Increment value	[Esc]+TINT←	Tint[X1]*[X15]←	Increase the tint by one.
Decrement value	[Esc]-TINT←	Tint[X1]*[X15]←	Decrease the tint by one.
View	[Esc]TINT←	[X15]←	View the tint setting.
Contrast			
Specify a value	[Esc][X15]CONT←	Cont[X1]*[X15]←	Set the contrast for the current input.
Increment value	[Esc]+CONT←	Cont[X1]*[X15]←	Increase the contrast by one.
Decrement value	[Esc]-CONT←	Cont[X1]*[X15]←	Decrease the contrast by one.
View	[Esc]CONT←	[X15]←	View the contrast setting.
Brightness			
Specify a value	[Esc][X15]BRIT←	Brit[X1]*[X15]←	Set the brightness on the current input.
Increment value	[Esc]+BRIT←	Brit[X1]*[X15]←	Increase the brightness by one.
Decrement value	[Esc]-BRIT←	Brit[X1]*[X15]←	Decrease the brightness by one.
View	[Esc]BRIT←	[X15]←	View the brightness setting.
KEY:			
[X1] = Input selection		1 - 6 (IN1606) or 1 - 8 (IN1608 Series)	
[X2] = Output selection		1 = HDMI A (top), 2 = HDMI B (bottom), 3 = Out C	
[X15] = Picture adjustment		Ø - 127 (64 = default)	
[X29] = Video output mute		Ø = unmute, 1 = mute video, 2 = mute video and sync	
[X55] = Video mute on all outputs		Ø = all outputs are unmuted	
		1 = at least one output is muted	
		2 = at least one output is muted and sync is disabled	

Command	ASCII Command (Host to Scaler)	Response (Scaler to Host)	Additional Description
Picture Adjustment Commands (continued)			
Detail Filter			
Specify a value	Esc X15 HDET ←	Hdet X1 * X15 ↵	Set the detail filter for the current input to X15 .
Increment value	Esc +HDET ←	Hdet X1 * X15 ↵	Increase the detail by one.
Decrement value	Esc -HDET ←	Hdet X1 * X15 ↵	Decrease the detail by one.
View	Esc HDET ←	X15 ↵	View the detail filter setting.
Horizontal Shift (Image)			
Specify a value	Esc X16 HCTR ←	Hctr X16 ↵	Set the horizontal position to X16 .
Increment value	Esc +HCTR ←	Hctr X16 ↵	Increase the horizontal position by one.
Decrement value	Esc -HCTR ←	Hctr X16 ↵	Decrease the horizontal position by one.
View	Esc HCTR ←	X16 ↵	View the horizontal position setting.
Vertical Shift (Image)			
Specify a value	Esc X17 VCTR ←	Vctr X17 ↵	Set the vertical position to X17 .
Increment value	Esc +VCTR ←	Vctr X17 ↵	Increase the vertical position by one.
Decrement value	Esc -VCTR ←	Vctr X17 ↵	Decrease the vertical position by one.
View	Esc VCTR ←	X17 ↵	View the vertical position setting.
Horizontal Size (Image)			
Specify a value	Esc X18 HSIZ ←	Hsiz X18 ↵	Set the horizontal size to X18 .
Increment value	Esc +HSIZ ←	Hsiz X18 ↵	Increase the horizontal size by one.
Decrement value	Esc -HSIZ ←	Hsiz X18 ↵	Decrease the horizontal size by one.
View	Esc HSIZ ←	X18 ↵	View the horizontal size setting.
Vertical Size (Image)			
Specify a value	Esc X19 VSIZ ←	Vsiz X19 ↵	Set the vertical size to X19 .
Increment value	Esc +VSIZ ←	Vsiz X19 ↵	Increase the vertical size by one.
Decrement value	Esc -VSIZ ←	Vsiz X19 ↵	Decrease the vertical size by one.
View	Esc VSIZ ←	X19 ↵	View the vertical size setting.
Compound Image Position and Size			
Specify a value	Esc X16 * X17 * X18 * X19 XIMG ←	Ximg X16 * X17 * X18 * X19 ↵	Set the horizontal and vertical positions as well as the horizontal and vertical sizes.
View	Esc XIMG ←	X16 * X17 * X18 * X19 ↵	View all position and size settings.
KEY:			
X1 = Input selection		1 - 6 (IN1606) or 1 - 8 (IN1608 Series)	
X15 = Picture adjustment		0 - 127 (64 = default)	
X16 = Horizontal position		±2048	
X17 = Vertical position		±1200	
X18 = Horizontal size		10 - 4096	
X19 = Vertical size		10 - 2400	

Command	ASCII Command (Host to Scaler)	Response (Scaler to Host)	Additional Description
Output Configuration Commands			
Output Scaler Rate			
Set output rate	[Esc] [X60] RATE ←	Rate [X60] ↵	Set the output resolution and rate to [X60] .
View output rate	[Esc] RATE ←	[X60] ↵	View the selected output rate.
HDMI Output Format			
Set format	[Esc] [X2] * [X33] VTPO ←	Vtpo [X2] * [X33] ↵	Set the color space and format of output [X2] to [X33] .
View setting	[Esc] [X2] VTPO ←	[X33] ↵	View the color space and format setting.
Power Save Mode			
Power save off	[Esc] ØPSAV ←	PsavØ ↵	Operate at full power.
Power save on	[Esc] 1PSAV ←	Psav1 ↵	Operate in a low power state (no video output).
View setting	[Esc] PSAV ←	[X37] ↵	View the power mode.
Screen Saver			
Set mode	[Esc] M [X27] SSAV ←	SsavM [X27] ↵	Set the color of the screen saver to [X27] .
View mode	[Esc] MSSAV ←	[X27] ↵	View the color of the screen saver.
Set custom color	[Esc] C [X28] SSAV ←	SsavC [X28] ↵	Set the color of the custom screen saver.
Set time-out duration	[Esc] T [X23] SSAV ←	SsavT [X23] ↵	Set the time-out duration to [X23] .
View time-out duration	[Esc] TSSAV ←	[X23] ↵	View the time-out duration.
View screen saver status	[Esc] SSSAV ←	[X38] ↵	View the screen saver status.
KEY:			
[X2] = Output selection		1 = HDMI A (top), 2 = HDMI B (bottom), 3 = Out C	
[X23] = Output sync timeout		Ø = output sync is instantly disabled with no active input 1 - 5ØØ (in 1 second increments) 5Ø1 = output sync never times out	
[X27] = Screen saver mode		Ø = custom color, 1 = black output (default), 2 = blue output	
[X28] = Custom screen saver color		ØØØØØØ (black) to FFFFFFFF (white) in HTML style hexadecimal values (for example, FFØØØØ = red, ØØFFØØ = green, and ØØØØFF = blue)	
[X33] = HDMI output format		Ø = auto (default) 1 = DVI RGB 444 2 = HDMI RGB 444 "Full" 3 = HDMI RGB 444 "Limited" 4 = HDMI YUV 444 "Full" 5 = HDMI YUV 444 "Limited" 6 = HDMI YUV 422 "Full" 7 = HDMI YUV 422 "Limited"	
[X37] = Power save mode		Ø = full power mode (default) 1 = low power state	
[X38] = Screen saver status		Ø = active input detected, timer not running 1 = no active input, timer running, output sync enabled 2 = no active input, timer expired, output sync disabled	
[X60] = Output rate		3 - 8, 1Ø - 92, 2Ø1, 2Ø2 (see the [X60] definition on page 49).	

Command	ASCII Command (Host to Scaler)	Response (Scaler to Host)	Additional Description
Audio Configuration Commands			
Audio Input Format			
NOTE: For audio input format details, see Audio format on page 99.			
Set audio input format	<code>[Esc] I [X1] * [X35] AFMT ←</code>	<code>Afmt I [X1] * [X35] ↵</code>	Set the audio format of input [X1] to [X35].
View audio input format	<code>[Esc] I [X1] AFMT ←</code>	<code>[X35] ↵</code>	View the audio input format of input [X1].
Audio Level Control			
Set gain or trim	<code>[Esc] G [X57] * [X58] AU ←</code>	<code>DsG [X57] * [X58] ↵</code>	Set the gain of [X57] to [X58].
View gain or trim	<code>[Esc] G [X57] AU ←</code>	<code>[X58] ↵</code> <code>DsG [X57] * [X58] ↵</code>	View the gain or trim of [X57]. Verbose mode 2 or 3.
Audio Mute			
Mute audio	<code>[Esc] M [X57] * 1 AU ←</code>	<code>DsM [X57] * 1 ↵</code>	Mute control [X57].
Unmute audio	<code>[Esc] M [X57] * Ø AU ←</code>	<code>DsM [X57] * Ø ↵</code>	Unmute control [X57].
View audio mute status	<code>[Esc] M [X57] AU ←</code>	<code>[X9] ↵</code> <code>DsM [X57] * [X9] ↵</code>	View the mute status of control [X57]. Verbose mode 2 or 3.
KEY:			
[X1] = Input selection		1 - 6 (IN1606) or 1 - 8 (IN1608 Series)	
[X9] = Enable or disable		Ø = off or disabled 1 = on or enabled	
[X35] = Audio input format		Ø = none (input muted) 1 = analog (default for inputs 1 and 2) 2 = LPCM-2Ch (default for inputs 3 and higher) 3 = Multi-Ch 4 = LPCM-2Ch auto 5 = Multi-Ch auto	
[X57] = Gain or mute control		4Ø1ØØ = mic 1 (mix volume only) 4ØØØØ = mic 1 (mute only) 4Ø1Ø1 = mic 2 (mix volume only) 4ØØØ1 = mic 2 (mute only) 6ØØØØ = output 1 6ØØØ2 = output 2 6ØØØ4 = left variable output 6ØØØ5 = right variable output 6ØØØ6 = left digital output 6ØØØ7 = right digital output 6ØØØ8 = left amplified output (stereo models) or amplified output (mono models) 6ØØØ9 = right amplified output (stereo models)	
[X58] = Gain or trim level		-1ØØØ to Ø = dB value multiplied by ten, in 0.1 dB increments (for example, -1ØØ = -10 dB), Ø = Default	

Command	ASCII Command (Host to Scaler)	Response (Scaler to Host)	Additional Description
Audio Configuration Commands			
Volume Knob Assignment			
Set volume knob group	[Esc] 1* [X56] KNOB←	Knob1* [X56] ↵	Set the front panel Volume knob value to affect group [X56] .
View volume knob group	[Esc] 1KNOB←	[X56] ↵	View the volume knob group.
Group Volume			
Set volume	[Esc] D [X46] * [X47] GRPM←	GrpmD [X46] * [X47] ↵	Set the volume to a value of [X47] .
Raise volume	[Esc] D [X46] * [X51] +GRPM←	GrpmD [X46] * [X47] ↵	Increase the volume by [X51] dB.
Lower volume	[Esc] D [X46] * [X51] -GRPM←	GrpmD [X46] * [X47] ↵	Decrease the volume by [X51] dB.
View volume level	[Esc] D [X46] GRPM←	[X47] ↵	View the volume level.
Group Mute			
Group mute	[Esc] D [X48] *1GRPM←	GrpmD [X48] *1↵	Mute group [X48] .
Group unmute	[Esc] D [X48] *ØGRPM←	GrpmD [X48] *Ø↵	Unmute group [X48] .
View group mute status	[Esc] D [X48] GRPM←	[X9] ↵	
Group Bass and Treble			
Set bass or treble level	[Esc] D [X49] * [X50] GRPM←	GrpmD [X49] * [X50] ↵	Set the bass or treble to a value of [X50] .
Raise bass or treble	[Esc] D [X49] * [X51] +GRPM←	GrpmD [X49] * [X50] ↵	Increase the volume by [X51] dB.
Lower bass or treble	[Esc] D [X49] * [X51] -GRPM←	GrpmD [X49] * [X50] ↵	Decrease the volume by [X51] dB.
View bass or treble level	[Esc] D [X49] GRPM←	[X50] ↵	
KEY:			
[X9] = Enabled or disabled		Ø = off or disabled	
		1 = on or enabled	
[X46] = Volume group number		1 = program volume	
		3 = mic volume	
		8 = variable volume	
[X47] = Group volume level		-1000 to Ø, where -1000 = -100 dB or 0% volume and	
		Ø = 0 dB or 100% volume	
[X48] = Mute group number		2 = program mute	
		4 = mic mute	
		7 = output mute	
[X49] = Bass and treble group number		5 = bass control	
		6 = treble control	
[X50] = Group bass and treble level		-240 to +120, where -240 = -24 dB and 120 = 12 dB	
[X51] = Increment value		dB value multiplied by ten, in 0.1 dB increments, to raise or	
		lower a group fader (for example, 100 = 10 dB)	
[X56] = Volume knob group number		1 = program volume (default)	
		3 = mic volume	
		8 = output volume	

Command	ASCII Command (Host to Scaler)	Response (Scaler to Host)	Additional Description		
Preset Commands					
Presets					
Setting	User Preset	Input Preset	Setting	User Preset	Input Preset
Horizontal and vertical start		Saved	Film detect		Saved
Active lines		Saved	Brightness and contrast	Saved	Saved
Pixel phase		Saved	Color and tint	Saved	Saved
Active and total pixels		Saved	Detail	Saved	Saved
Input type		Saved	Size and position	Saved	Saved
Audio gain and attenuation		Saved	Preset name	Saved	Saved
Recall user preset	1 * X21 .	1Rpr X21 ↵	Recall user preset X21 .		
Save user preset	1 * X21 ,	1Spr X21 ↵	Save the current picture controls.		
Delete user preset	Esc X1 * X21 PRST ←	PrstX1 * X21 ↵	Clear user preset X21 .		
Recall input preset	2 * X22 .	2Rpr X22 ↵	Recall input preset X22 .		
Save input preset	2 * X22 ,	2Spr X22 ↵	See the table below for settings.		
Delete input preset	Esc X2 * X22 PRST ←	PrstX2 * X22 ↵	Clear input preset X22 .		
Preset Names					
<p>NOTE: To clear a preset name, enter a single space character for X14. This resets the preset name to the default value: “[User Preset XX]” for user presets or “[Input Preset XXX]” for input presets. This is valid only for existing presets.</p>					
Write user preset name	Esc 1 * X21 , X14 PNAM ←	Pnam1 * X21 , X14 ↵	Set user preset X21 name to X14 .		
View user preset name	Esc 1 * X21 PNAM ←	X14 ↵	View the name of user preset X21 .		
Write input preset name	Esc 2 * X22 , X14 PNAM ←	Pnam2 * X22 , X14 ↵	Set input preset X22 name to X14 .		
View input preset name	Esc 2 * X22 PNAM ←	X14 ↵	View the name of user preset X22 .		
Auto Memories (per input)					
Enable	Esc X1 * 1AMEM ←	Amem X1 * 1 ↵	Enable Auto Memory on input X1 .		
Disable	Esc X1 * ØAMEM ←	Amem X1 * Ø ↵	Disable Auto Memory on input X1 .		
View	Esc X1 AMEM ←	X9 ↵ Amem X1 * X9 ↵	View the status on input X1 . Verbose mode 2 and 3		
Preset Availability					
Query input preset availability	51#	X9 ¹ X9 ² ... X9 ¹²⁸ ↵ PreI X9 ¹ ... X9 ¹²⁸ ↵	View the status of all input presets. Verbose modes 2 and 3		
Query user preset availability	52 * X1 #	X9 ¹ X9 ² ... X9 ¹⁶ ↵ PreU X1 * X9 ¹ ... X9 ¹⁶ ↵	View the status of all user presets. Verbose modes 2 and 3		
KEY:					
X1 = Input selection		1 - 6 (IN1606) or 1 - 8 (IN1608 Series)			
X9 = Assigned or unassigned		Ø = disabled or unassigned, 1 = enabled or assigned			
X14 = Text label		Up to 16 characters			
X21 = User presets		1 - 16			
X22 = Input presets		1 - 128			

Command	ASCII Command (Host to Scaler)	Response (Scaler to Host)	Additional Description
Advanced Configuration Commands			
Test Pattern			
Set pattern	Esc X20 TEST ←	Test X20 ↵	Set test pattern X20 .
View test pattern	Esc TEST ←	X20 ↵	View the current test pattern.
Freeze			
Enable	1F	Frz1 ↵	Freeze the current input.
Disable	∅F	Frz∅ ↵	Unfreeze the current input.
View	F	X9 ↵	View the freeze setting.
Video Switch Effect			
Cut	Esc ∅SWEF ←	Swef∅ ↵	Set the switch effect to cut.
Fade through black	Esc 1SWEF ←	Swef1 ↵	Set the switch effect to fade through black (default).
View setting	Esc SWEF ←	X32 ↵	View the switch effect setting.
Input Aspect Ratio (per input)			
Set for fill	Esc X1 *1ASPR ←	Aspr X1 *1 ↵	Fill the entire output.
Set to follow	Esc X1 *2ASPR ←	Aspr X1 *2 ↵	Maintain the input aspect ratio.
View aspect setting	Esc X1 ASPR ←	X26 ↵	View the aspect ratio setting.
Front Panel Lockout Mode (Executive Mode)			
Enable mode 1	1X	Exe1 ↵	Lock the entire front panel.
Enable mode 2	2X	Exe2 ↵	Limit front panel control to input switching and volume control only.
Disable	∅X	Exe∅ ↵	Unlock the front panel.
View status	X	X24 ↵	View the lock mode.
KEY:			
X1 = Input selection		1 - 6 (IN1606) or 1 - 8 (IN1608 Series)	
X9 = Enabled or disabled		∅ = off or disable 1 = on or enable	
X20 = Test patterns		∅ = none (default) 1 = crop 2 = alternating pixels 3 = color bars 4 = grayscale 5 = blue mode 6 = audio test pattern (pink noise)	
X24 = Front Panel Lockout mode status		∅ = off or disabled (default) 1 = mode 1 (complete front panel lockout) 2 = mode 2 (input selection and volume control only)	
X26 = Aspect ratio setting		1 = fill (default) 2 = follow	
X32 = Video switching effect		∅ = cut 1 = fade through black (default)	

Command	ASCII Command (Host to Scaler)	Response (Scaler to Host)	Additional Description
Advanced Configuration Commands (continued)			
Overscan Mode (applies only to SMPTE input resolutions)			
Set value	[Esc] [X3] * [X25] OSCN ←	0scn [X3] * [X25] ↵	Set the overscan value to [X25] .
View status	[Esc] [X3] OSCN ←	[X25] ↵	View the overscan setting.
HDCP Notification (displayed on non-HDCP displays with HDCP input selected)			
Enable notification	[Esc] N1HDCP ←	HdcpN1 ↵	Display a green screen.
Disable notification	[Esc] NØHDCP ←	HdcpNØ ↵	Mute output to black.
Query notification	[Esc] NHDCP ←	[X9] ↵	View the HDCP notification setting.
HDCP Status			
Query input	[Esc] I [X1] HDCP ←	[X31] ↵ HdcpI [X1] * [X31] ↵	View the HDCP status on input [X1] (inputs 3+ only). Verbose modes 2 and 3
Query output	[Esc] O [X2] HDCP ←	[X31] ↵ HdcpO [X2] * [X31] ↵	View the HDCP status on output [X2] . Verbose modes 2 and 3
HDCP Authorized Setting (valid for HDMI inputs only, to allow or block HDCP input signals)			
Enable HDCP authorization	[Esc] E [X1] * 1HDCP ←	HdcpE [X1] * 1 ↵	Enable HDCP authorization (inputs 3+ only).
Disable HDCP authorization	[Esc] E [X1] * ØHDCP ←	HdcpE [X1] * Ø ↵	Disable HDCP authorization (inputs 3+ only).
Query HDCP authorization status	[Esc] E [X1] HDCP ←	[X39] ↵	View HDCP authorization setting (inputs 3+ only).
KEY:			
[X1] = Input selection		1 - 6 (IN1606) or 1 - 8 (IN1608 Series)	
[X2] = Output selection		1 = HDMI A (top) 2 = HDMI B (bottom) 3 = Out C	
[X3] = Input video format		1 = RGB 2 = YUV 3 = RGBcvS 4 = S-video 5 = Composite 6 = HDMI	
[X9] = Enable or disable		Ø = off or disabled 1 = on or enabled	
[X25] = Overscan		Ø = 0.0% (default for RGB and HDMI) 1 = 2.5% (default for YUV, RGBcvS, S-Video, and CV) 2 = 5.0%	
[X31] = HDCP status		Ø = no sink or source device detected 1 = sink or source detected with HDCP 2 = sink or source detected but no HDCP is present	
[X39] = HDMI input HDCP authorization status		Ø = block HDCP encryption 1 = allow HDCP encryption (default)	

Command	ASCII Command (Host to Scaler)	Response (Scaler to Host)	Additional Description
Advanced Configuration Commands (continued)			
HDCP Mode (valid for HDMI outputs only)			
Set HDCP mode	[Esc] S [X59] HDCP ←	Hdcp S [X59] ↵	Set the HDCP mode to [X59] .
View HDCP mode setting	[Esc] SHDCP ←	[X59] ↵ Hdcp S [X59] ↵	View the HDCP mode. Verbose modes 2 and 3
Video Signal Presence			
View video signal presence status	[Esc] ØLS ←	[X36] * [X36] *... [X36] * [X36] ↵	View video signal presence for all inputs.
		In ØØ • [X36] * [X36] * [X36] * [X36] * [X36] ↵	Verbose modes 2 and 3
KEY:			
[X36] = Video signal status		Ø = video/HDMI signal not detected 1 = video/HDMI signal detected	
[X59] = HDCP mode		Ø = encrypts the output only when required by the selected input source (default) 1 = always encrypts the output, regardless of the HDCP status of the selected input source 2 = encrypts the output only when required by the selected input source. Use this setting when DVI sink devices initially pass HDCP encrypted content, but intermittently display a green HDCP notification screen after a power cycle or resuming from sleep mode. 3 = always encrypts the output regardless of the HDCP status of the selected input source. Use this setting when DVI sink devices initially pass HDCP encrypted content, but intermittently display a green HDCP notification screen after a power cycle or resuming from sleep mode. 4 = prevents HDCP encryption and authentication.	

Command	ASCII Command (Host to Scaler)	Response (Scaler to Host)	Additional Description
Device Commands			
On-screen Input “Bug” Time-out			
NOTE: The OSD bug is a floating message displayed after selecting a new input.			
Set OSD bug time-out	Esc X23 MDUR ←	Mdur X23 ↵	Set the duration the OSD bug displays to X23 seconds (003 = default).
View time-out	Esc MDUR ←	X23 ↵	View the OSD duration.
NOTE: Setting the time-out to 501 permanently displays the OSD bug (never times out). Setting the time-out to 0 disables the OSD bug.			
Reset			
Erase user-supplied web pages and files ^{24 28}	Esc <i>filename</i> EF ←	Del • <i>filename</i> ↵	Delete imported web pages and files.
Erase current directory and files ^{24 28}	Esc / EF ←	Dd1 ↵	Delete the current directory and files.
Erase current directory and subdirectories ^{24 28}	Esc // EF ←	Dd1 ↵	Delete the current directory and subdirectories.
Erase flash memory ²⁴	Esc ZFFF ←	Zpf ↵	Clear the flash memory.
Reset all device settings to factory default ²⁴	Esc ZXXX ←	Zpx ↵	Reset all device settings to factory default.
Absolute system reset ²⁴ (includes setting DHCP to Off and the IP address to 192.168.254.254)	Esc ZQQQ ←	Zpq ↵	Reset all device settings, including DHCP and IP settings, to factory defaults.
NOTE: Entering this command or performing a mode 5 reset via the rear panel Reset button (see the Reset Modes Summary table on page 41) resets the current passwords to no password.			
Absolute system reset ²⁴ (retain IP)	Esc ZY ←	Zpy ↵	Reset all device settings, excluding IP settings.
Verbose Mode			
Set verbose mode	Esc X53 CV ←	Vrb X53 ↵	Enable or disable verbose mode and tagged responses, where additional information is provided in response to a query.
View verbose mode	Esc CV ←	X53 ↵	View the verbose mode.
KEY:			
X23 = On-screen display bug time-out		0 = OSD bug is never displayed	
		1 - 500 (in 1 second increments)	
		3 = default	
		501 = OSD bug never times out	
X53 = Verbose mode		0 = clear or none (default for Telnet connections)	
		1 = verbose mode (default for RS-232 connections)	
		2 = tagged responses for queries	
		3 = verbose mode and tagged queries	

Command	ASCII Command (Host to Scaler)	Response (Scaler to Host)	Additional Description
Device Commands (continued)			
Information Request			
General Information	I	Vid[X1]•Aud[X1]•Typ[X3]•Std[X10]•Blk[X29]•... Hrt[X13]•Vrt[X13]↵	
Query firmware version	Q	x.xx↵	View firmware version.
Query full firmware version	*Q	x.xx.xxxx↵	View full firmware version.
Query part number	N	<part number>↵	View the part number.
View internal temperature	[Esc]2ØSTAT↵	[X11]↵	View the temperature in degrees Celsius.
Backup or Restore Configuration			
NOTE: For more details, see Backup and Restore on page 79.			
Save configuration to file system	[Esc]1*[X45]XF↵	Cfg1*[X45]↵	Back up the current device configuration.
Restore configuration from file system	[Esc]Ø*[X45]XF↵	CfgØ*[X45]↵	Restore device configuration.
Device Naming			
Set unit name ²⁴	[Esc][X14]CN↵	Ipn•[X14]↵	Set the device name to [X14].
Set unit name to factory default ²⁴	[Esc]•CN↵	Ipn•[X34]↵	Reset the device name to the factory default.
View unit name	[Esc]CN↵	[X14]↵	View the device name.
KEY:			
[X1] = Input selection		1 - 6 (IN1606) or 1 - 8 (IN1608 Series)	
[X3] = Input video format		1 = RGB, 2 = YUV, 3 = RGBcvS, 4 = S-video, 5 = composite 6 = HDMI	
[X10] = Input standard		Ø = no signal detected on the current input 1 = NTSC 3.85 2 = PAL 3 = NTSC 4.43 4 = SECAM - = not applicable (occurs when the input is active RGB, YUV, or HDMI signals)	
[X11] = Internal temperature		In degrees Celsius	
[X13] = Horizontal and vertical frequencies		xxx.x	
[X14] = Text label		Up to 63 characters	
[X29] = Video output mute		Ø = unmute 1 = mute video 2 = mute video and sync	
[X34] = Default name		A combination of model name and the last 3 character pairs of the MAC address	
[X45] = Config type		Ø = IP config 2 = box-specific parameters	

Command	ASCII Command (Host to Scaler)	Response (Scaler to Host)	Additional Description
IP Control Port Commands			
IP Setup			
NOTE: Changes made to any TCP/IP settings do not take effect until the reboot networking command (Esc 2B00T ←) is issued.			
Set DHCP mode ²⁴	Esc X9 DH ←	I dh X9 ↵	Enable or disable DHCP.
View DHCP mode	Esc DH ←	X9 ↵	View the DHCP mode setting.
Set IP address ²⁴	Esc X40 CI ←	I pi ● X40 ↵	Set the IP address to X40 .
Read IP address	Esc CI ←	X40 ↵	View the current IP address.
Set subnet mask ²⁴	Esc X41 CS ←	I ps ● X41 ↵	Set the subnet mask to X41 .
View subnet mask	Esc CS ←	X41 ↵	View the subnet mask setting.
Set gateway IP address ²⁴	Esc X42 CG ←	I pg ● X42 ↵	Set the gateway IP address to X42 .
View gateway IP address	Esc CG ←	X42 ↵	View the gateway IP address setting.
Read MAC address	Esc CH ←	X43 ↵ I ph ● X43 ↵	00-05-A6-xx-xx-xx Verbose mode 2 and 3.
Query the number of open connections	Esc CC ←	X44 ↵ I cc X44 ↵	View the number of open connections. Verbose mode 2 and 3.
Reboot networking	Esc 2B00T ←	Boo t2 ↵	Restart the network after IP setting or DHCP changes.
Zeroconf (mDNS) Discovery Services			
Set Zeroconf (mDNS) discovery services	Esc X9 ZCON ←	Z con X9 ↵	Enable or disable Zeroconf (mDNS) discovery services.
View Zeroconf (mDNS) discovery services setting	Esc ZCON ←	X9 ↵	View the Zeroconf (mDNS) discovery services setting.
KEY:			
X9 = Enable or disable		0 = off or disabled (default for DHCP mode commands) 1 = on or enabled (default for Zeroconf commands)	
X40 = IP address		xxx.xxx.xxx.xxx (192.168.254.254 = default)	
X41 = Subnet mask		xxx.xxx.xxx.xxx (255.255.0.0 = default)	
X42 = Gateway address		xxx.xxx.xxx.xxx (0.0.0.0 = default)	
X43 = MAC address		00-05-A6-xx-xx-xx	
X44 = Number of open connections		0- <i>maximum number of open connections</i>	

Command	ASCII Command (Host to Scaler)	Response (Scaler to Host)	Additional Description
IP Control Port Commands (continued)			
Passwords			
NOTES:			
<ul style="list-style-type: none"> • Passwords are case-sensitive. • / \ * and <i>space</i> are invalid for passwords. • A password cannot be a single space. • The factory configured passwords for all accounts on this device have been set to the device serial number. In the event of a reset to factory defaults, the passwords are reset to no password. 			
Set administrator password	Esc X52 CA ←	Ipa • X52 ←	Set the administrator password to X52 . Passwords are case-sensitive. By default the factory configured admin password is the password device serial number on all accounts on the device.
View administrator password	Esc CA ←	**** ← or ← <i>In verbose modes 2 and 3:</i> Ipa **** ←	View the administrator password. If there is a valid password, the response is **** ←. if there is no password, the response is ←.
Reset (clear) administrator password	Esc • CA ←	Ipa • ←	Reset or clear the administrator password.
Set user password	Esc X52 CU ←	Ipu • X52 ←	Set the user password.
View user password	Esc CU ←	**** ← or ← <i>In verbose modes 2 and 3:</i> Ipu • ←	View the user password. If there is a valid password, the response is **** ←. if there is no password, the response is ←.
Reset (clear) user password	Esc • CU ←	Ipu • ←	Reset or clear the user password.
KEY:			
X52 = Password		0 to 128 characters (/ \ * or <i>space</i> are not allowed)	

Configuration Software

The Extron Product Configuration Software (PCS) offers another way to control the scalers via USB, or TCP/IP connection. The graphical interface includes the same functions as those on the device front panel with additional features that are available only through the software.

This section describes the software installation and communication (see [Internal Web Pages](#) beginning on page 85 or see the *IN1606 and IN1608 Series Product Configuration Software Help File* for detailed control information). Topics in this section include:

- [Software Installation](#)
- [Software Connection](#)
- [Software Overview](#)

The control software is compatible with Microsoft Windows operating systems. The software program is available on the [Extron website](#).

Software Installation

To download PCS from the Extron website, locate it on the Download Center page.

Software Download Center Page

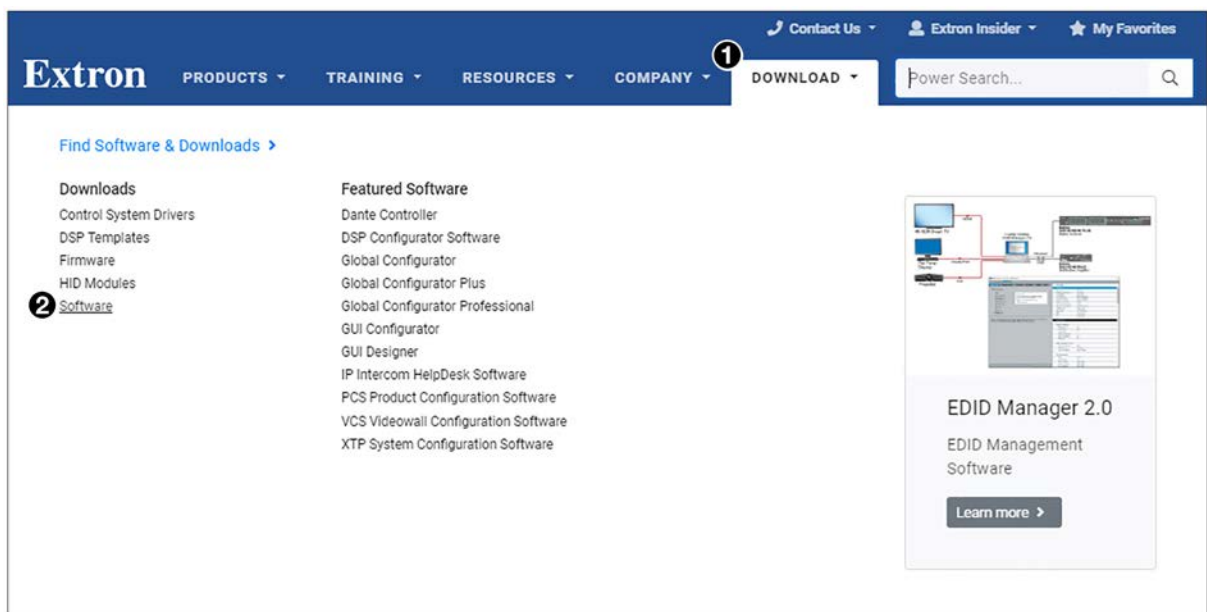

Figure 32. Download Center Page on the Extron Website

1. On the Extron website, select the **DownLoad** tab (see figure 32, **1**).

2. Move the pointer to the **Software** link (see [figure 32](#), **2**, on the previous page) in the Downloads column and click it.

Download Center
Software (84 files)

NEW

VCS

Dante Controller

Global Configurator

Global Configurator Plus and Global Configurator Professional

GUI Configurator

ALL # A B C D E F G H I J K L M N O **P** Q R S T U V W X Y Z

Archives

Please consult Release Notes for important compatibility information and history.

Description	Part Number	Version	Date	Size	
PCS Updated Product Configuration Software for a variety of standalone products. Learn more Release Notes	79-562-01	4.3.1	Aug. 15, 2018	170.4 MB	Download
PIP 422 & 444 Control Software for PIP 422 & 444. Release Notes	79-522-01	1.0	Jan. 12, 2007	8.9 MB	Download

Figure 33. PCS Download Link

3. On the Download Center page, click the **P** link (see [figure 33](#), **1**).
4. If necessary, scroll to locate PCS from the list of available software programs and click the **Download** link to the right of the name (**2**).
5. On the login page that appears next, fill in the required information to log in to www.extron.com (if you need an ID number, see your Extron representative).
6. Follow the instructions on the subsequent screens to complete the software program installation. By default, the configuration program files are stored on your computer at: C:\Program Files (x86)\Extron\IN1606 and IN1608 Series.

If there is not already an Extron folder in your Program Files (x86) folder, the installation program creates it as well.

Software Connection

Open the Product Configuration Software program from the **Start** menu or desktop shortcut. The Extron Product Configuration Software window opens with the **Device Discovery** panel open. Connect to the scaler using the **Device Discovery** panel or the **TCP/IP** panel.

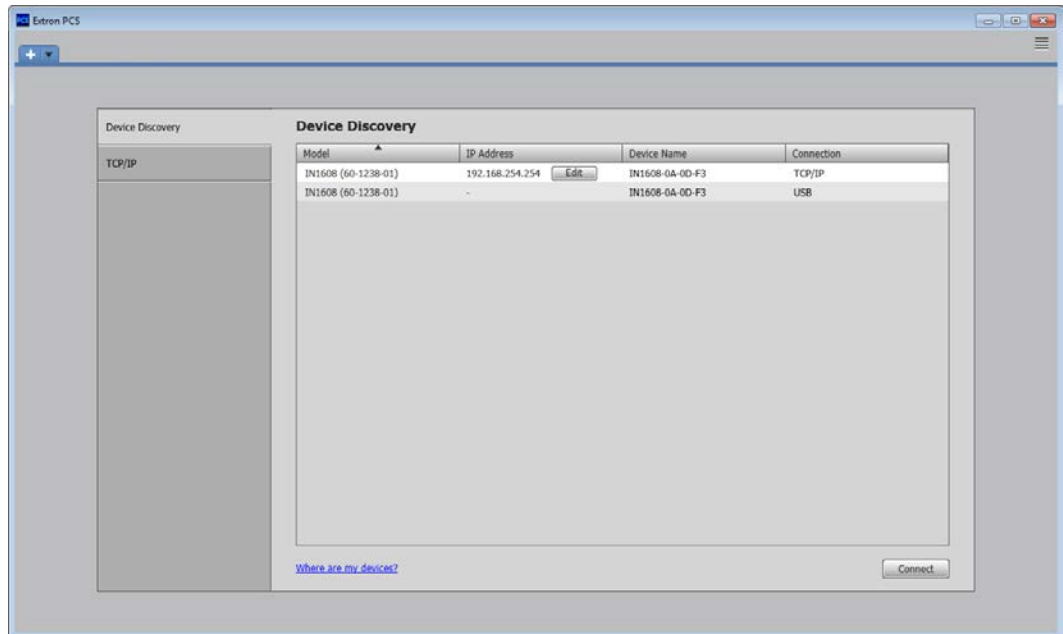

Figure 34. PCS Window

NOTE:

- PCS versions prior to 2.0 do not have the Device Discovery feature. If possible, update the PCS version from the [Extron website](#). If that is not possible, connect to the scaler by choosing the connection method and submitting the required information in the current PCS version.
- Verify the current version of PCS supports the desired device by reviewing the software Release Notes, also available on the Extron website.

Offline device configuration is not supported with the IN1606 or IN1608 Series scalers, but the configuration screens and panels can still be viewed.

Device Discovery Panel

The Device Discovery panel displays accessible Extron devices connected directly to the PC or to a LAN or WAN. Devices are identified and sorted by model, IP address, device name, or connection method.

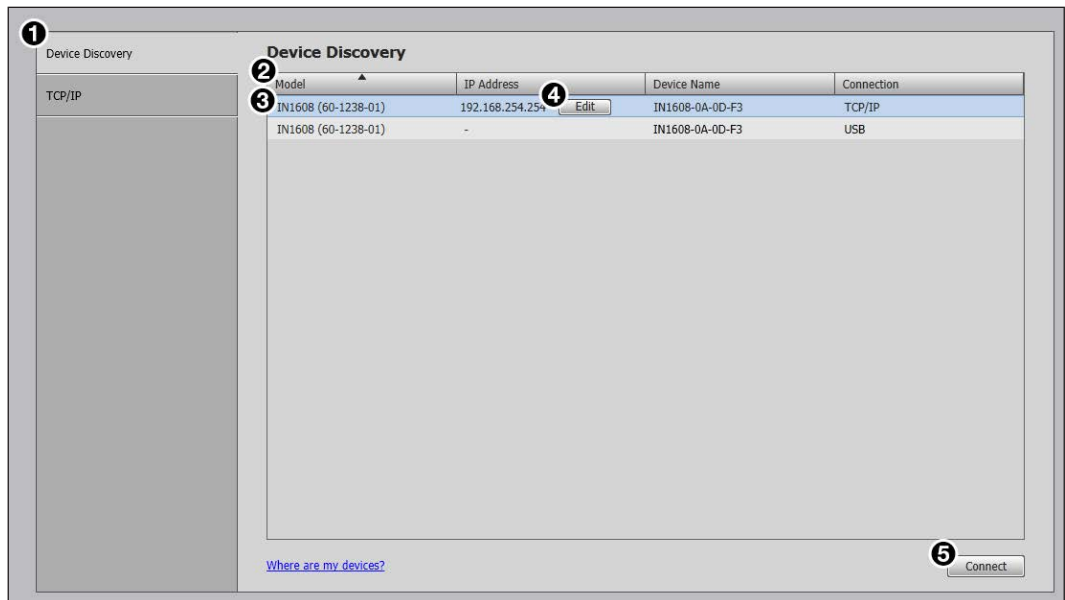

Figure 35. Device Discovery Panel

To sort the list of available devices:

1. Click the **Device Discovery** tab (see figure 35, ❶).
2. Click the desired column heading (❷) to sort the category in ascending or descending order.

To connect to a device:

1. Click the **Device Discovery** tab (❶).
2. Select the desired device (❸).
3. Click the **Connect** button (❺). A new device configuration tab opens.

To edit communication settings from the Device Discovery panel:

1. Click the **Device Discovery** tab (❶).
2. Click the **Edit** button of the desired device (❹). The Communication Settings dialog box opens.
3. See [Ethernet settings](#) on page 119 for configuration details.

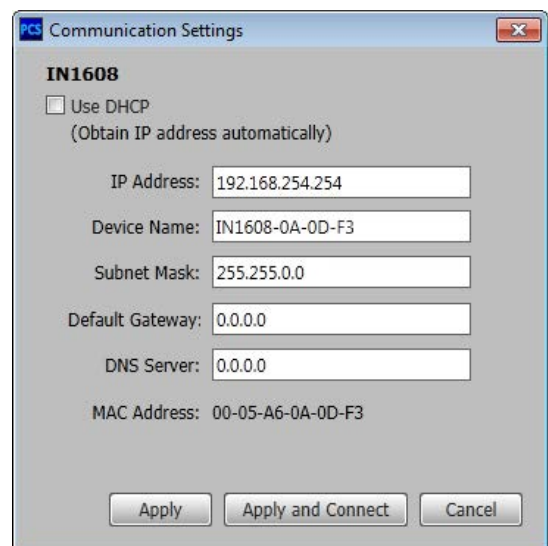

4. Finalize the settings in one of the following ways (see the [Communication Settings screen](#) on the previous page):
 - Click the **Apply** button to accept the changes and return to the **Device Discovery** panel.
 - Click the **Apply and Connect** button to accept the changes and connect to the selected device. A new device configuration tab opens.
 - Click the **Cancel** button to cancel any pending changes and return to the **Device Discovery** panel.

TCP/IP Panel

The TCP/IP panel connects PCS to a specific device through Ethernet.

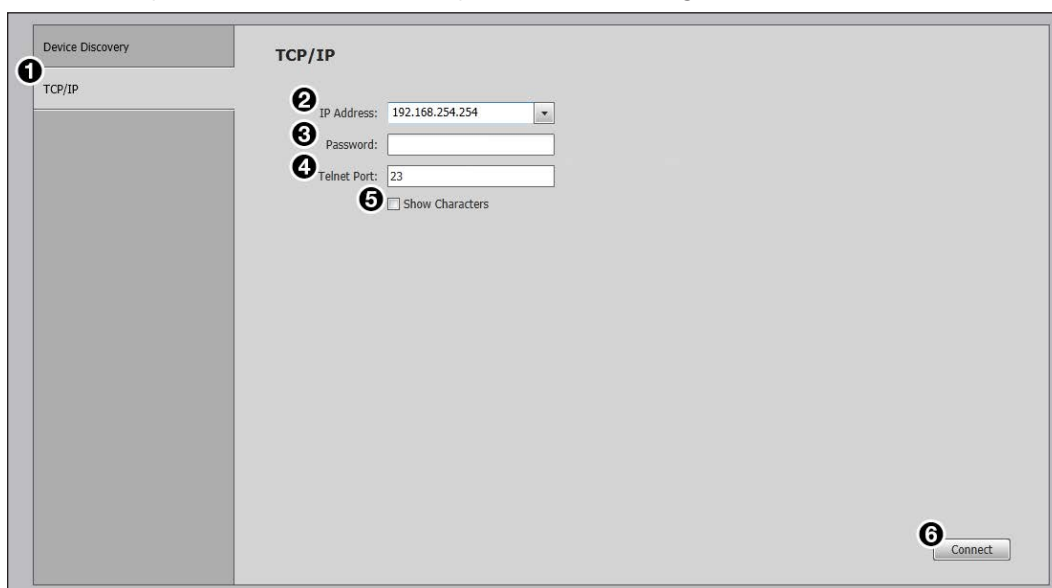

Figure 36. TCP/IP Panel

1. Click the **TCP / IP** tab (see figure 36, **1**).
2. In the **IP Address** field (**2**), enter the IP address of the desired device.
3. If required, enter the device password in the **Password** field (**3**).

NOTES:

- Select the **Show Characters** checkbox (**5**) to display the password characters.
- The factory configured passwords for all accounts on this device have been set to the device serial number. Passwords are case sensitive. In the event of a reset to factory defaults, the passwords are set to no password.

4. In the **Telnet Port** field (**4**), enter the Telnet port of the desired device.
5. Click the **Connect** button (**6**). A new device tab opens.

Offline Device Preview

Opening a new device tab for an offline device displays the interface and configuration options for the chosen model without connecting to it. However, settings cannot be changed.

To open a scaler device tab:

1. In the **Start-up** drop-down menu, select **New Configuration File**. The New Configuration File dialog box opens.

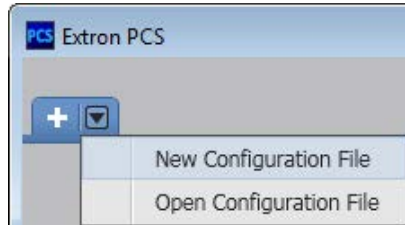

Figure 37. Configuration File Drop-Down Menu

NOTE: The **Open Configuration File** option is not available for the IN1606 or IN1608 Series.

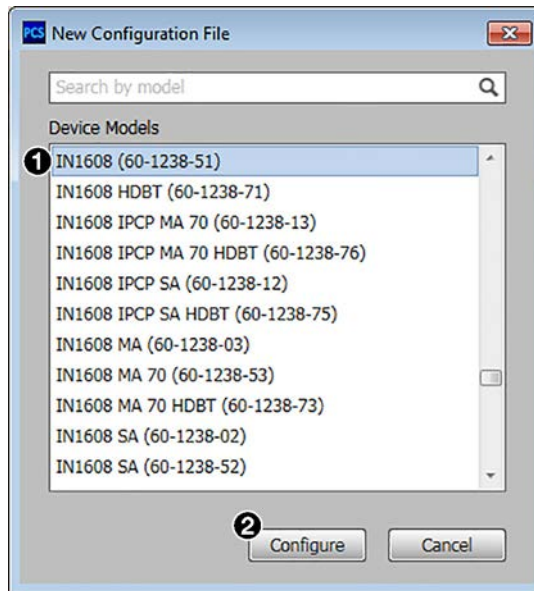

Figure 38. New Configuration File Dialog Box (IN1608 Selected)

2. Select the desired device model from the Device Models list (see figure 38, ①).
3. Click the **Configure** button (②). A new offline device configuration tab opens.

Software Overview

NOTE: For specific software features, see [Internal Web Pages](#) beginning on page 85 or open the *IN1606 and IN1608 Series Product Configuration Software Help* file.

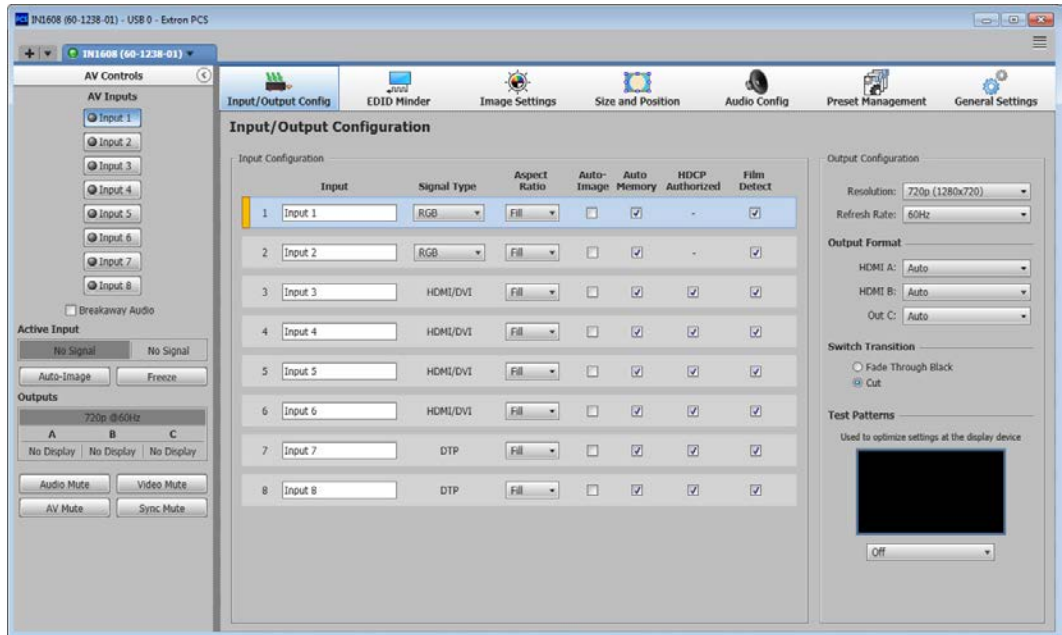

Figure 39. Online Device Tab (IN1608)

Each device tab has a **Device** drop-down menu for configuration options. The **Software** menu contains software configuration and information options.

Software Menu

The **Software** menu (see figure 40) contains options pertaining to PCS settings.

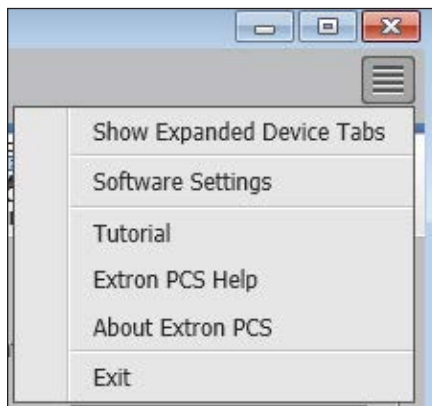

Figure 40. Software Menu

Show Expanded Device Tabs

This option displays the device IP address or connection method in the **Device** tab.

From the **Software** menu, select **Show Expanded Device Tabs**.

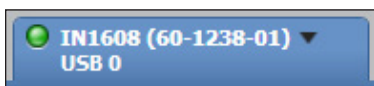

Figure 41. Expanded Device Tab (IN1608 Connected through USB)

Software Settings

This option resets all disabled confirmation dialogs to the default settings.

1. From the **Software Menu**, select **Software Settings**. The Software Settings dialog box opens.

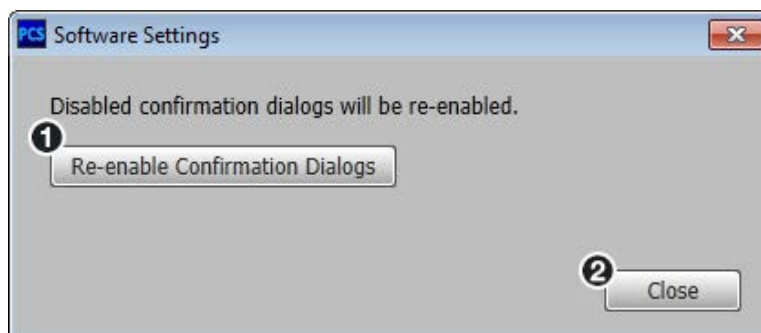

Figure 42. Software Settings Dialog Box

2. Click the **Re-enable Confirmation Dialogs** button (1). The dialog box closes and the reset is complete. Click the **Close** button (2) to close the dialog box without re-enabling the confirmation dialogs.

Tutorial

This option displays a general overview of where to find features in the PCS framework.

1. From the **Software** menu, select **Tutorial**. The Tutorial dialog box opens.
2. Click the **OK** button to close the dialog box.

Extron PCS Help

This options opens the PCS Help file for general PCS operations. For product-specific help files, see [Help](#) on page 84.

From the **Software** menu, select **Extron PCS Help**.

About Extron PCS

This option contains information about the current PCS version.

1. From the **Software** menu, select **About Extron PCS**. The About - Extron PCS dialog box opens.



Figure 43. About - Extron PCS Dialog Box

2. Click the **Details** button for more information.
3. Click the **OK** button to close the dialog box.

Exit

This option disconnects PCS from connected devices and closes the application.

1. From the **Software** menu, select **Exit**. If device tabs are open, the Exit dialog box opens.

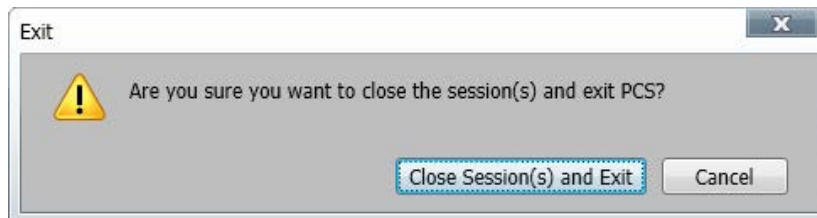

Figure 44. Exit Dialog Box

2. If necessary, click the **Close Session(s) and Exit** button to disconnect the software from connected devices, close all offline device tabs, and close the software. Click the **Cancel** button to leave the software open.

Device Menu

The **Device** drop-down menu contains options pertaining to device connection, configuration, and information.

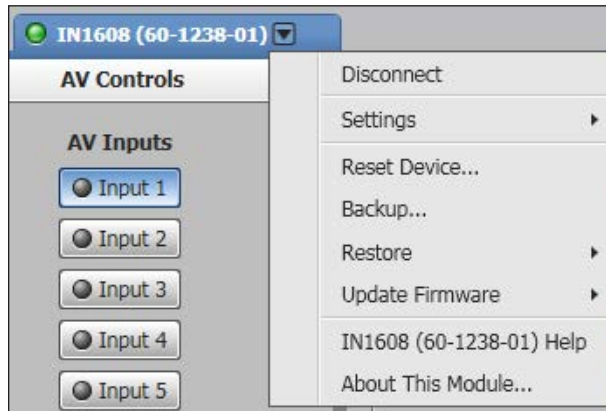

Figure 45. Device Menu (IN1608)

Disconnect

This option disconnects the PCS program from the connected device and closes the device tab.

From the **Device** drop-down menu, select **Disconnect**.

NOTE: If a device is already disconnected, the **Disconnect** option is disabled until the device is connected.

Settings

Hardware Settings

This option displays device information or lets you change the device name, internal clock, and password of the connected device.

NOTE: The factory configured passwords for all accounts on this device have been set to the device serial number. Passwords are case sensitive. In the event of a reset to factory defaults, the passwords are set to no password.

From the **Device** drop-down menu, select **Settings > Hardware Settings...** The Hardware Settings dialog box opens. For configuration details, see [Hardware Pages](#) on page 117.

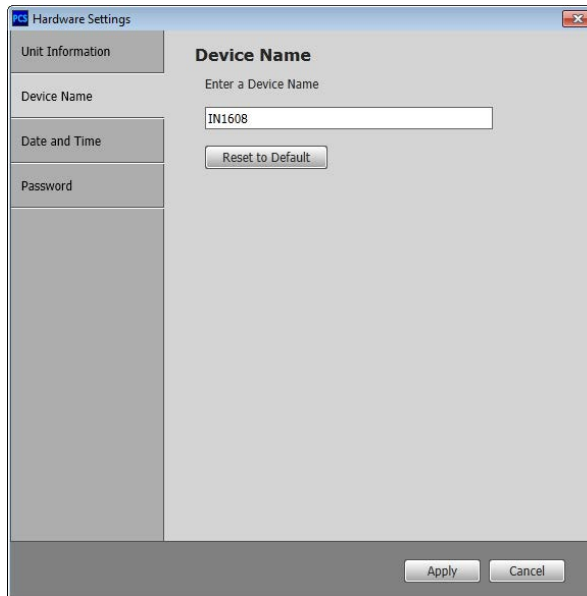

Figure 46. Hardware Settings Dialog Box

Click the **Apply** button to accept pending changes.

Click the **Cancel** button to cancel any pending changes and close the dialog box.

Communication Settings

This option changes communication settings of the connected device.

From the **Device** drop-down menu, select **Settings > Communication Settings...** The Communication Settings dialog box opens. For configuration details, see [Communication Settings Page](#) on page 119.

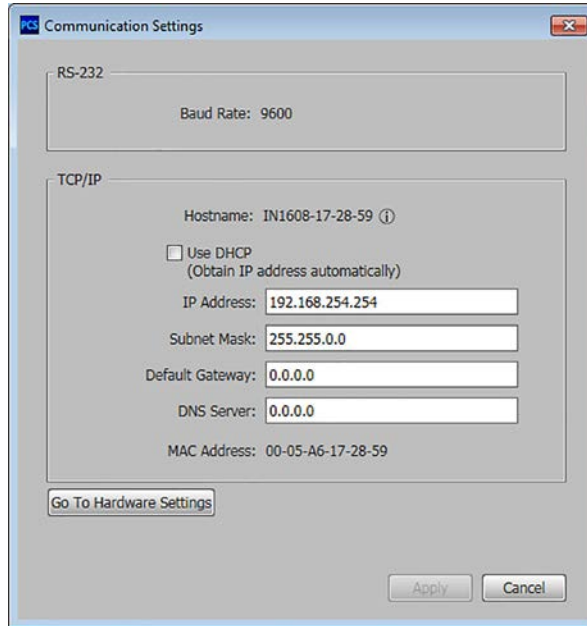

Figure 47. Communication Settings Dialog Box

Click the **Apply** button to accept pending changes.

Click the **Cancel** button to cancel any pending changes and close the dialog box.

Reset Device

This option contains selectable reset modes for resetting the connected device.

From the **Device** drop-down menu, select **Reset Device...** The Reset Device dialog box opens.

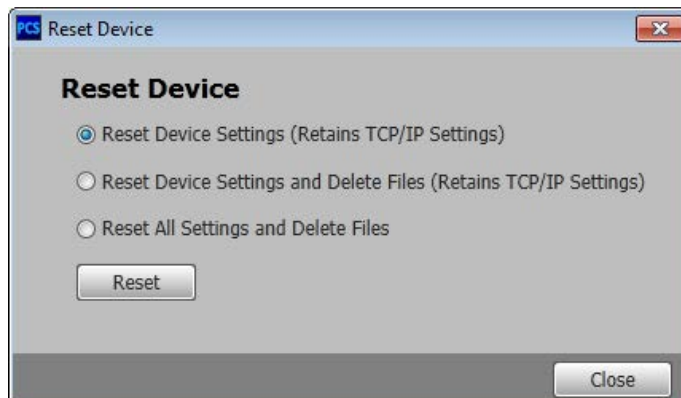

Figure 48. Reset Device Dialog Box

For device reset details, see [Reset Device Page](#) on page 124.

Backup

This option exports all audio, video, and communication settings of the connected device to the PC. This exported configuration can be saved as a backup, or be used to replicate settings from one device to other devices of the same model. When restoring a configuration, specific device settings can be selected.

To save a configuration:

1. From the **Device** drop-down menu, select **Backup**. The Backup window opens.
2. Navigate to the desired save location on the PC.
3. Click the **Save** button. The window closes.

Restore

The **Restore** options load a saved configuration (see “Backup” above) for the same device model to the connected device or multiple devices of the same model on a connected LAN. Saved configurations may include audio, video, and communication settings.

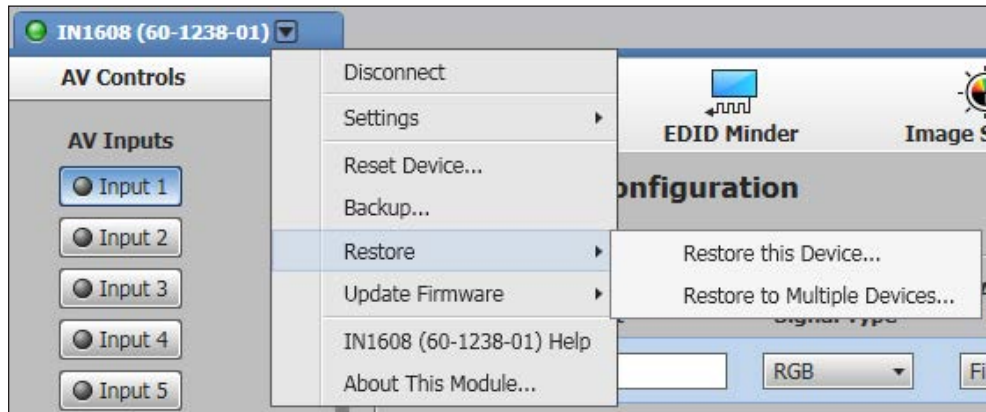

Figure 49. Restore Options

Restore this Device

The **Restore this Device** option loads a saved configuration to the connected device.

To restore a saved configuration to the connected device:

1. From the **Device** drop-down menu, select **Restore... > Restore this Device...**. The Restore This Device dialog box opens.

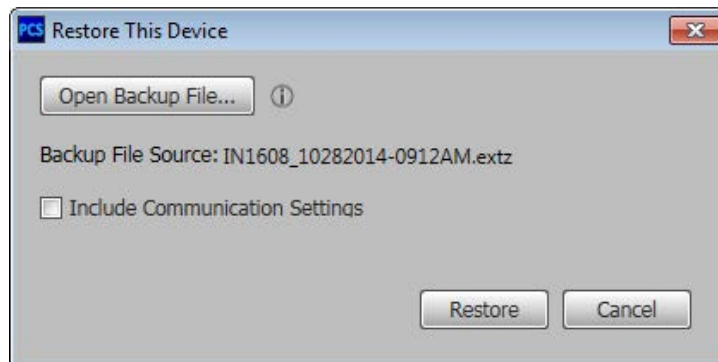

Figure 50. Restore This Device Dialog Box

2. Click the **Open Backup File...** button. The Open Backup File window opens.
3. Navigate to the save location of the saved file

4. Select the file and click the **Open** button. The Open Backup File window closes.

NOTE: Valid configuration files have a .extz file extension.

5. If desired, select the **Include Communication Settings** checkbox to include communication settings to the restored configuration.
6. Click the **Restore** button to apply the saved configuration settings. A confirmation dialog box opens.

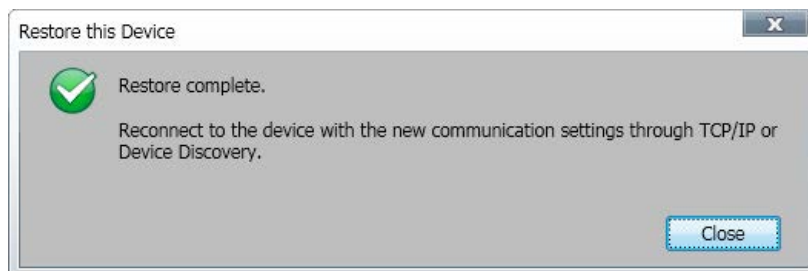

Figure 51. Restore this Device Confirmation Dialog Box

7. Click the **Close** button to close the Restore this Device dialog box.

Restore to Multiple Devices

The Restore to Multiple Devices option loads a saved configuration file to multiple devices on the network (see **Backup** on page 79 to save a configuration to the PC).

NOTE: The connected devices must be connected via LAN.

From the **Device** drop-down menu, select **Restore... > Restore to Multiple Devices...** The Restore to Multiple Devices dialog box opens (see figure 52).

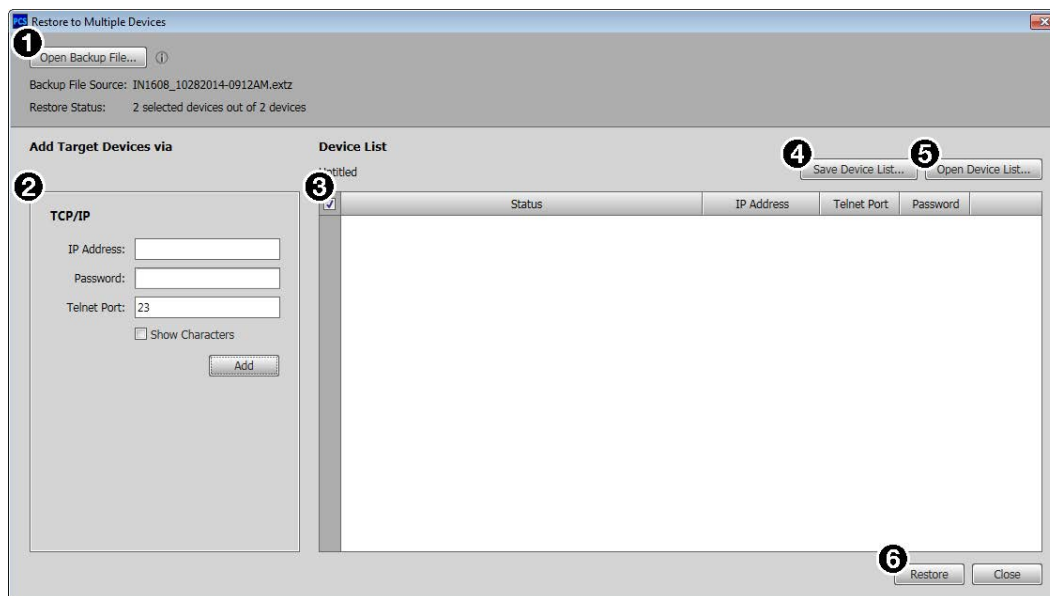

Figure 52. Restore Multiple Devices Dialog Box

To restore a saved configuration file to multiple devices:

1. Click the **Open Backup File** button (1) in the top left corner.
2. Navigate to the location of the saved file.
3. Select the file and click the **Open** button. The Open Backup File window closes.

NOTE: Valid configuration files have a .extz file extension.

4. Add target devices to the Device List in any of the following ways:
 - In the TCP/IP panel (see [figure 52](#), [2](#), on the previous page), enter the necessary information for the target device in the **IP Address**, **Password**, and **Telnet** fields and click the **Add** button.

NOTES:

- A configuration is not loaded to a device if the TCP/IP information is invalid, the target device is not connected, or the target device is not powered.
 - The factory configured passwords for all accounts on this device have been set to the device serial number. Passwords are case sensitive. In the event of a reset to factory defaults, the passwords are set to no password.
- Click the **Open Device List...** button ([5](#)) to open the **Open Device List** window and navigate to the location of a saved device list file. Select the desired file and click the **Open** button to load the list of devices.
5. In the left column of the Device List, select the checkboxes of the desired devices to restore the saved configuration file.
 6. Click the **Restore** button ([6](#)) to load the file to the selected devices.

To save the current list of target devices:

1. Click the **Save Device List...** button ([4](#)). The **Save Device List** window opens.
2. Navigate to the desired save location.
3. Click the **Save** button. The **Save Device List** window closes.

To open a previously saved device list:

1. Click the **Open Device List...** button ([5](#)). The **Open Device List** window opens.
2. Navigate to the location of the saved device list file and select it.
3. Click the **Open** button. The **Open Device List** window closes.

NOTE: Valid files have a .mfst file extension.

To edit the communication settings of target devices in the device list:

NOTE: A configuration is not loaded to a device if the TCP/IP information is invalid, the target device is not connected, or the target device is not powered.

1. In the same row as the desired device, select the  icon. The **Edit** dialog box opens.
2. Enter the new values in the appropriate fields (they are the same as in the TCP/IP panel).

To remove a target device from the device list:

In the same row as the desired device, select the  icon.

Update Firmware

The update firmware options upload firmware from the host device to the connected device or multiple devices.

NOTE: If necessary, download new firmware from the Extron website (see [Downloading Updated Firmware](#) on page 128).

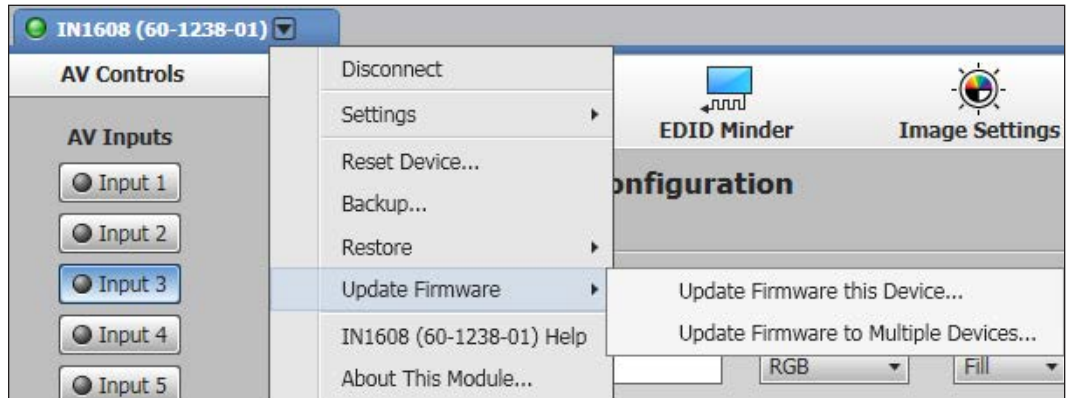

Figure 53. Update Firmware Options

Update Firmware this Device...

The Update Firmware this Device... option uploads firmware from the host device to the connected device only.

1. From the **Device** drop-down menu, select **Update Firmware > Update Firmware this Device...** A dialog box opens to ask permission to disconnect from the device.
2. Click the **Continue** button to disconnect from the device and continue with the firmware update process. The Update Firmware dialog box opens.

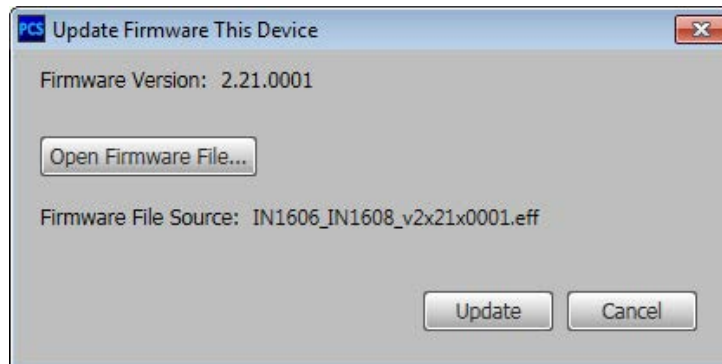

Figure 54. Update Firmware This Device Dialog Box

3. Click the **Open Firmware File...** button. The Open Firmware File window opens.
4. Navigate to the desired firmware file and select the device-specific firmware file.

NOTE: Valid firmware files have an .eff or .esf file extension.

5. Click the **Open** button. The Open Firmware File window closes.
6. In the Update Firmware This Device dialog box, click **Update**. The progress bar shows the progress of the firmware upload to the device.

Update Firmware to Multiple Devices...

The Upload Firmware to Multiple Devices option uploads firmware to multiple devices on the network.

NOTE: The connected devices must be connected via LAN.

From the **Device** drop-down menu, select **Update Firmware > Update Firmware to Multiple Devices...** The Update Firmware to Multiple Devices dialog box opens.

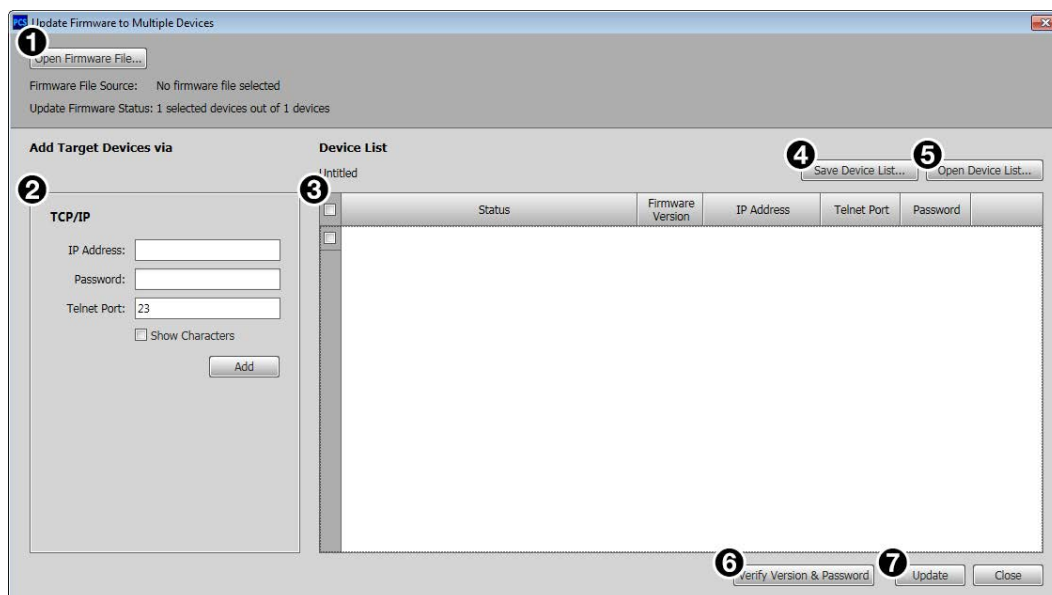

Figure 55. Update Firmware to Multiple Devices Dialog Box

To update firmware to multiple devices:

1. Click the **Open Firmware File** button (1) in the top left corner. The Open Firmware File window opens.
2. Navigate to the location of the saved file.
3. Select the file and click the **Open** button. The Open Firmware File window closes.

NOTE: Valid firmware files have a .eff or .esf file extension.

4. Add target devices to the Device List in one of the following ways:
 - In the TCP/IP panel (2), enter the necessary information for the target device in the **IP Address**, **Password**, and **Telnet Port** fields and click the **Add** button.

NOTE: The factory configured passwords for all accounts on this device have been set to the device serial number. Passwords are case sensitive. In the event of a reset to factory defaults, the passwords are set to no password.

- Open a previously saved device list (see [To open a previously saved device list](#) on the next page).
5. In the left column of the Device List, select the checkboxes of the desired devices to update the firmware.
 6. Click the **Verify Version & Password** button (6) to verify all selected devices and passwords are compatible and valid. Any connection issues are noted in the **Status** field. Correct any issues before proceeding.
 7. Click the **Update** button (7) to load the file to the selected devices.

To save the current list of target devices:

1. Click the **Save Device List...** button (see [figure 55](#), [4](#)). The Save Device List window opens.
2. Navigate to the desired save location.
3. Click the **Save** button. The Save Device List window closes.

To open a previously saved device list:

1. Click the **Open Device List...** button ([5](#)). The Open Device List window opens.
2. Navigate to the location of the saved device list file and select it.
3. Click the **Open** button. The Open Device List window closes.

NOTE: Valid files have a .mfst file extension.

To edit the communication settings of target devices in the device list:

NOTE: A firmware file is not loaded to a device if the TCP/IP information is invalid, the target device is not connected, or the target device is not powered.

1. In the same row as the desired device, select the  icon. The Edit dialog box opens.
2. Enter the new values in the appropriate fields (they are the same as in the TCP/IP panel).

To remove a target device from the device list:

In the same row as the desired device, select the  icon.

Help

This option contains a link to the device help file.

From the **Device** drop-down menu, select device-specific **Help**. The help file opens in a separate window.

About This Module

This option contains the device module part number and firmware version of the connected device.

1. From the **Device** drop-down menu, select **About This Module...** The About This Module dialog box opens.



Figure 56. About This Module Dialog Box

2. Click the **Close** button to close the dialog box.

Internal Web Pages

The scalers feature an on-board web server, displayed as a set of internal web pages. These pages allow for control and operation of the scaler through a LAN or WAN connection. Use a web browser to view the pages on a PC connected to the scaler.

NOTE: The scaler internal web pages do not support compatibility mode in Microsoft® Internet Explorer® (see [Turning Off Compatibility Mode](#) on the next page). Extron recommends using Mozilla® Firefox® or Google Chrome™.

This section gives an overview of the internal web pages, which are always available and cannot be erased or overwritten. Topics in this section include:

- [Using the Internal Web Pages](#)
- [AV Controls Panel](#)
- [Configuration Pages](#)
- [Hardware Pages](#)

Using the Internal Web Pages

Accessing the Internal Web Pages

1. Connect the scaler to a LAN or WAN using the rear panel RJ-45 connector.
2. Open a web browser on a connected PC.
3. Enter the IP address of the device in the browser **Address** field.

NOTE: The default IP address is 192.168.254.254.

4. Press the <**Enter**> key on the keyboard.
5. The scaler checks if the device is password-protected.
 - If the device is not password-protected, the web pages open.
 - If the device is password-protected, enter a user name entry (“user” or “admin”) in the **User Name** field and the password in the **Password** field when prompted.

NOTE: The factory configured passwords for all accounts on this device have been set to the device serial number. Passwords are case sensitive. In the event of a reset to factory defaults, the passwords are set to no password.

6. Click the **OK** button.

Turning Off Compatibility Mode

The internal web pages do not support compatibility mode in Microsoft Internet Explorer.

To check compatibility view settings:

From the Tools menu of the browser, select **Compatibility View Settings**. The Compatibility View Settings dialog box opens.

Be sure that the **Display all websites in Compatibility View** checkbox is clear, and that the IP address of the scaler is not in the list of websites that have been added to Compatibility View.

Navigating the Internal Web Pages

The internal web pages open with two main tabs: **Configuration** (see [figure 58](#), ①, on page 88) and **Hardware** (see [figure 81](#), ①, on page 117). Below the tabs is a global navigation bar with icons that open various pages for configuration settings and information.

Each page is separated into the AV Controls panel and the individual page.

AV Controls Panel

The AV Controls panel controls AV settings such as input selection, performing a one-time Auto-Image to an input, video and audio mute, and image freeze.

At the bottom of the panel is a summary of the current active input and output status, including signal format and HDCP status.

NOTE: This panel can be hidden or revealed on any page by clicking on the arrow button on the top right of the panel.



Figure 57. AV Controls Panel

The unlocked icon indicates that an input or output is not HDCP-encrypted. The lock with a check mark icon indicates that an input or output is HDCP-encrypted.

Auto-Image Button

Click the **Auto-Image** button (see [figure 57](#), **1**, on the previous page) to start a one-time Auto-Image on the currently selected input.

AV Inputs Buttons

Click an input button (**2**) to select an input. As a new input is selected, the summary within the panel changes to reflect the new input and output status.

NOTE: The signal indicators on the AV input buttons display green when a signal is present on the corresponding input or gray when there is no signal present.

Breakaway Audio Checkbox

Select the **Breakaway Audio** checkbox (**3**) to enable audio breakaway. The input buttons separate into two columns: video and audio.

In the **Video** column, click the input button associated with the video to be used.

In the **Audio** column, click the input button associated with the audio to be used.

NOTES:

- Audio breakaway is not available to inputs configured for digital audio formats.
- Video breakaway is not available from inputs configured for digital video formats.

Video and Audio Mute and Freeze Buttons

- Click the **Video Mute** button (**4**) to mute only the video signal. The button turns red.
- Click the **Audio Mute** button (**5**) to globally mute only the audio. The button turns red.
- Click the **AV Mute** button (**6**) to mute both video and audio simultaneously. The button turns red, along with the **Video Mute** and **Audio Mute** buttons.
- Click the **Freeze** button (**7**) to freeze the current video frame. The button turns blue.



NOTE: For the software only, click the **Sync Mute** button to mute video and sync. The button turns red along with the **Video Mute** button.

To unmute or unfreeze any signal, click the appropriate button. The button reverts to the default color, indicating the signal has been unmuted or unfrozen.



NOTE: Changing inputs unfreezes a signal as well.

Input and Output Information

If available, the **Active Input** panel displays the resolution and refresh rate of the active input signal as well as the HDCP status.

Symbol	Definition
 HDCP	The signal is HDCP encrypted.
	The signal is not encrypted.
-	Unable to determine the HDCP status.
No Signal	There is no signal detected.

If available, the **Outputs** panel displays the resolution and refresh rate of the output as well as the HDCP status of all connected outputs.

Symbol	Definition
	The display is HDCP compliant.
	The display is not HDCP compliant.
—	Unable to determine the HDCP status.
No Display	There is no display detected.

Configuration Pages

The configuration pages contain options for input and output configuration, EDID management, image settings, image size and position, audio configuration, preset management, and device settings.

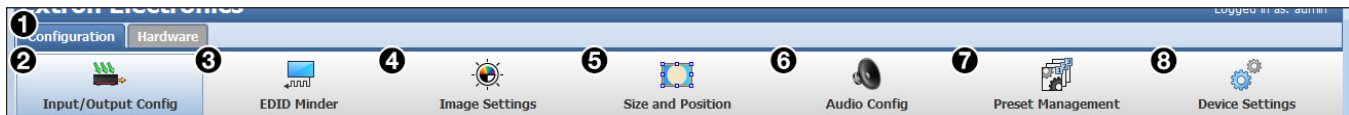

Figure 58. Global Navigation Bar - Configuration

Input and Output Configuration Page

Click the **Input/Output Config** icon on the **Global Navigation Bar** (see figure 58, ②) to open this page. It contains panels for input configuration and output configuration.

Input Configuration panel

The **Input Configuration** panel consists of user configurable fields for each input. These include input naming, signal type, aspect ratio, automatic Auto-Image, Auto Memory, HDCP Authorized status, and Film Detect.



Figure 59. Input Configuration Panel (IN1608)

NOTE: DTP inputs 7 and 8 are not available on the IN1606.

Input (renaming)

By default, the name associated with an input channel is **Input <number>**. To rename an input, click inside the desired input field (see [figure 59, 1](#), on the previous page) and type in the desired name to identify the input. Input names have a 16-character limit.

NOTE: Entering a single space character resets the name of the input to the default.

Signal type

From the **Signal Type** drop-down menu ([2](#)), select the signal type for inputs 1 and 2 from **RGB** (default), **YUV**, **RGBcvs**, **S-Video**, and **Composite**. For all other inputs, HDMI/DVI is the only available signal type.

Aspect ratio

From the **Aspect Ratio** drop-down menu ([3](#)), select **Fill** or **Follow**.

- **Fill** — Scales the input signal to fill the entire video output.
- **Follow** — Follows the signal aspect ratio, with respect to the current output resolution setting. Black letter box or pillar box bars may be applied for aspect ratio compensation.

Auto-Image

Select the **Auto-Image** checkbox ([4](#)) of the desired input to enable an automatic Auto-Image to an input. When enabled, Auto-Image is applied whenever there is a change in the input sync. Auto-Image attempts to size and center the input signal based on the aspect ratio setting.

By default, the Auto-Image threshold is 25% brightness. Analog video signals greater than the threshold are considered active video. To change the threshold value, use SIS commands (see [Auto-Image Threshold Value](#) on page 52).

Auto Memory

Select the **Auto Memory** checkbox ([5](#)) of the desired input to enable the Auto Memory (see the [Auto Memory and Auto-Image Interaction table](#) on page 38 for a summary of the interaction between Auto Memory and Auto-Image). Auto Memory recalls input and image settings for signals that have previously been applied. When Auto Memory is disabled, the scaler treats every newly applied input as a new source.

HDCP Authorized

Select the **HDCP Authorized** checkbox ([6](#)) to enable or disable the HDCP Authorized feature (inputs 3 and higher). This feature determines if a digital input will report as an HDCP authorized sink to a source.

NOTE: This option is not available for analog inputs 1 and 2.

For source devices that require encryption, enable HDCP Authorized. If HDCP Authorized is disabled for sources that require encryption (for example, a Blu-ray player), the output is muted or a warning message is displayed.

Some source devices may encrypt their output even if the source material does not require HDCP encryption, preventing content from being displayed on a non-HDCP compliant display. Disable HDCP Authorized to allow the output of the scaler to remain unencrypted.

Film Detect

Select the **Film Detect** checkbox ([7](#)) of the desired input to enable automatic 3:2 and 2:2 film pulldown detection for NTSC, PAL, SECAM, and 1080i input signals.

Output Configuration panel

The Output Configuration panel contains controls for output resolution and rate, format settings, switch transitions, and available test pattern selection.

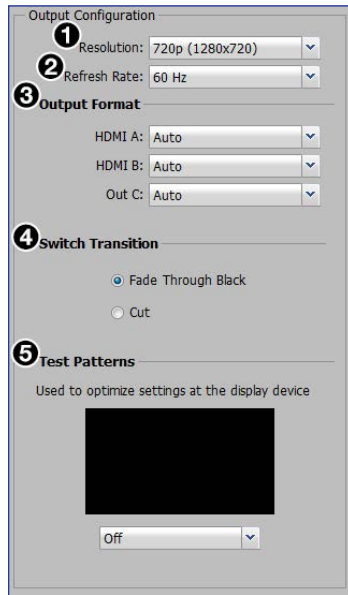

Figure 60. Output Configuration (IN1608)

Resolution

From the Resolution drop-down menu (see figure 60, ①), select the applicable output resolution.

Refresh rate

From the Refresh Rate drop-down menu (②), select the applicable output refresh rate.

Output formats

From the HDMI A, HDMI B, or Out C drop-down menu (③), select the applicable digital signal format.

Switch transitions

From the Switch Transitions panel (④), select one of the following radio buttons:

- **Fade Through Black** — Fades video to a black screen before switching to the newly selected video.
- **Cut** — Switches video directly to the newly selected input.

Test patterns

To aid display device setup and optimization, select a test pattern from the drop-down menu (⑤) under the preview window (see [Test Pattern](#) on page 36 for more details).



Figure 61. Available Test Patterns

NOTE: No input signal is needed when using a test pattern for display device setup.

EDID Minder Page

EDID Minder is a management process that manages the EDID information between the scaler and one or more input sources. Click the **EDID Minder** icon (see [figure 58](#), ③, on page 88) on the Global Navigation Bar to open the EDID Minder page.

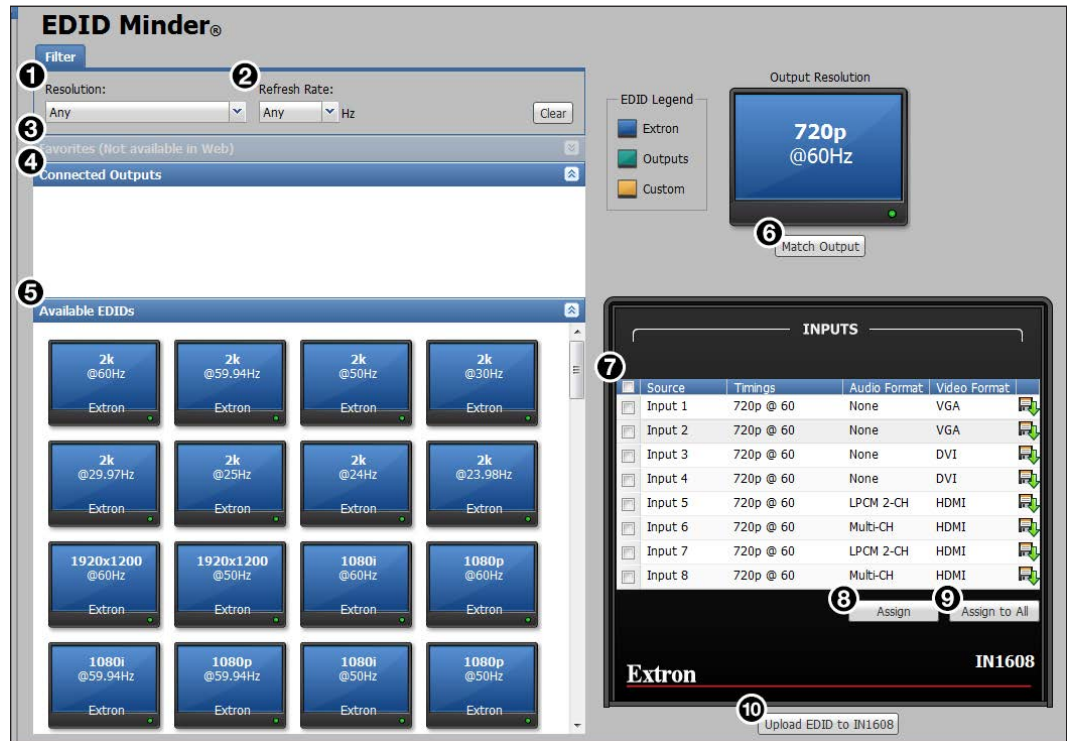

Figure 62. EDID Minder Page (IN1608)

The EDID properties currently assigned to each input are displayed in the list of inputs. The audio input format listed in an EDID is determined by the audio input format selected on the Audio Configuration page (unless a custom EDID is used).

Audio Input Format	Audio Capabilities Listed in EDID
None	No audio
Analog	No audio
LPCM-2Ch	2-channel audio
Multi-Ch	Multi-channel audio
LPCM-2Ch Auto	2-channel audio
Multi-Ch Auto	Multi-channel audio

If desired, the scaler can store up to six or eight custom EDID files. Audio settings from custom EDID files take priority over current settings on the input.

NOTE: If an analog custom EDID file is assigned to a digital input or a digital custom EDID file is assigned to an analog input, the display may not appear correctly.

EDID filters

Use the **Filter** tab to limit the number of available EDID displayed in the **Available EDIDs** and **Connected Outputs** panes.

1. From the **Resolution** drop-down menu (see **figure 62, ①**, on the previous page), select a specific resolution or **Any**.
2. From the **Refresh Rate** drop-down menu (**②**), select a specific refresh rate or **Any**.

EDID assignment

To assign EDID to selected inputs:

1. From the inputs group box (table of inputs) on the right, select the checkboxes for the desired inputs (**⑦**).
2. From the **Favorites** (PCS only), **Available EDIDs**, or **Connected Outputs** pane (**③-⑤**) on the left, select the desired EDID.
3. From the inputs group box, click the **Assign** button (**⑧**) to assign EDID to the selected input or inputs.

To assign EDID to all inputs:

1. From the **Favorites** (PCS only), **Connected Outputs**, or **Available EDIDs** pane (**③-⑤**), select an EDID.
2. From the inputs group box, click the **Assign to All** button (**⑨**).

NOTE: Checked or unchecked inputs are ignored and the EDID is assigned to all inputs.

To match the selected inputs to the current output resolution:

Matching the output resolution is the default value for all inputs.

1. From the inputs group box (table of inputs) on the right, select the checkboxes for the desired inputs (**⑦**).
2. In the **Output Resolution** panel, click the **Match Output** button (**⑥**).

EDID Library and EDID files

The EDID Library contains the list of available EDID files.

To add EDID files to the EDID Library:

1. Click the **Upload EDID to [Scaler]** button (**⑩**). The **Browse Add EDID to Library** window opens.
2. Navigate to the desired EDID file location and select the EDID file.

NOTE: Valid EDID files have a .bin file extension.

3. Click the **Open** button. The EDID is added to the **Available EDIDs** pane (**⑤**).

To save configurations as EDID files to a PC:

1. From the **Connected Outputs** (**④**, web only), **Available EDIDs** pane (**⑤**, web only), or the **Inputs** list (**⑦**), right-click on an EDID or input.
2. Select **Save EDID to PC**.
3. Click the **OK** button to save the file.

NOTE: Saving a factory scaler EDID exports an HDMI, LPCM-2Ch EDID to the PC. The file is saved as a .bin file.

Image Settings Page

The **Image Settings** page adjusts signal sampling and picture control settings, saves and recalls user and input presets, and applies overscan settings. Click the **Image Settings** icon (see [figure 58](#), ④, on page 88) on the **Global Navigation Bar** to open the **Image settings** page.

The screenshot shows the **Image Settings** interface. It is divided into several sections:

- Signal Sampling:** Contains adjustable fields for Active Lines (1200), Active Pixels (1600), Horizontal Start (128), Vertical Start (128), Total Pixels (2160), and Pixel Phase (31). Each field has up/down arrows and a range of Min and Max values. Asterisks indicate default values. Buttons at the bottom include **Auto-Image**, **Auto-Image & Fill**, and **Auto-Image & Follow**.
- Picture Controls:** Features sliders for Brightness (63), Contrast (63), Color (NA), Tint (NA), and Detail (63).
- Overscan:** Explains that overscan can be applied to SMPTE inputs. It includes dropdowns for DVI/HDMI (0.0%), RGBcvS (2.5%), RGB (0.0%), S-Video (2.5%), YUV (2.5%), and Composite (2.5%).
- Input Presets:** A list of 11 input presets (INPUT PRESET 001 to 011) with **Save Preset**, **Recall Preset**, and **Clear** buttons.
- User Presets:** A list of 10 user presets (USER PRESET 01 to 10) with **Save Preset**, **Recall Preset**, and **Clear** buttons.

Figure 63. Image Settings Page

Signal Sampling panel

Signal sampling optimizes the input signal to the scaler for the currently selected input.

This close-up view of the **Signal Sampling** panel highlights specific features:

- 1:** Points to the **Active Lines** field, which is set to 1200. An asterisk indicates it is a default value.
- 2:** Points to the **Auto-Image** button.
- 3:** Points to the **Auto-Image & Fill** button.
- 4:** Points to the **Auto-Image & Follow** button.

Figure 64. Signal Sampling Panel

To manually adjust signal sampling settings, enter a value within the Min and Max values displayed to the right of each adjustable setting (see [figure 64](#), ①) or click the **Up** or **Down** arrows. An asterisk beside a chosen value for a signal sampling setting indicates that it is a default value for the applied video signal (for example, see **Active Lines** in [figure 64](#)).

To automatically adjust these settings, perform one of the following:

- Click the **Auto-Image** button (②) to perform a one-time Auto-Image.
- Click the **Auto-Image & Fill** button (③) to perform a one-time Auto-Image and fill the entire video output (ignores aspect ratio setting).
- Click the **Auto-Image & Follow** button (④) to perform a one-time Auto-Image and to maintain the aspect ratio of the input signal (ignores aspect ratio setting).

Picture Controls panel

The Picture Controls panel shows adjustable image settings for the selected input.

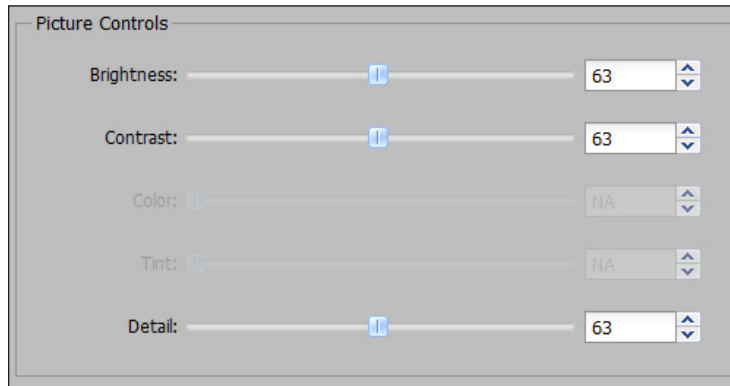

Figure 65. Picture Controls Panel

To adjust the picture settings, click and drag the associated slider for any image setting (brightness, contrast, color, tint, or detail) to the desired value.

Alternatively, enter a value within the field associated with the image setting, or click the **Up** and **Down** arrows to change the value in the field.

Overscan panel

Overscan mode zooms and crops SMPTE input resolutions to mask edge effects and ancillary data common in broadcast signals. Issuing an Auto-Image with overscan enabled runs an Auto Phase routine (YUV and RGB only) and centers and sizes the input.

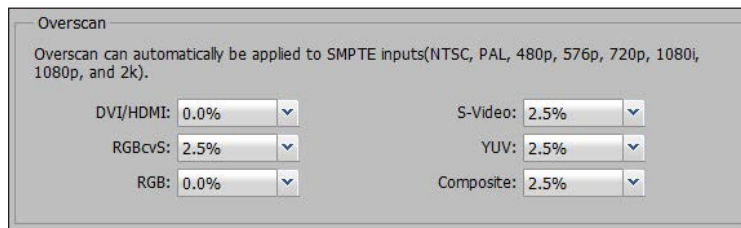

Figure 66. Overscan Panel

For each input signal type, select a value from the corresponding drop-down menu.

NOTE: Setting a value of 0% disables overscan for the corresponding input format.

Presets panel

Presets save output settings to be recalled through RS-232, USB, or Ethernet (see the following table for a comparison of saved settings for input and user presets).

Settings Included Within Presets		
Setting	User Preset	Input Preset
Horizontal and vertical start		Saved
Active lines		Saved
Pixel phase		Saved
Active pixels		Saved
Total pixels		Saved
Input type		Saved
Audio gain and attenuation		Saved
Film detect		Saved
Brightness and contrast	Saved	Saved
Color and tint	Saved	Saved
Detail	Saved	Saved
Image size and position	Saved	Saved
Preset name	Saved	Saved

NOTE: User presets can be saved on one input resolution and recalled on a different one. Input presets can only be recalled on the same input resolution that was present when the preset was saved.

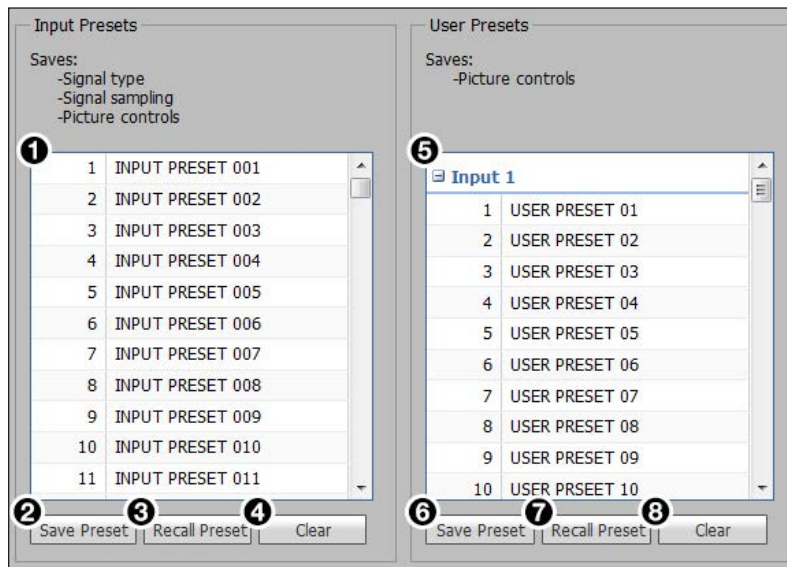

Figure 67. Input and User Presets Panels

There are 128 presets that are global to all inputs. The presets contain all of the settings for an input when used with an upstream matrix switcher. Input presets save signal type, signal sampling, and picture control settings.

There are 16 user presets per input to save picture control settings only.

To save a preset:

1. From the Input Presets list (see [figure 67](#), **1**, on the previous page) or the User Presets list (**5**), select the desired preset.
2. Click the **Save Preset** button (**2** or **6**) in the same panel as the selected preset. If the selected preset already has stored information on it, the **Presets** dialog box opens. Click the **Overwrite** button to erase the previous data and save the new settings. Click the **Cancel** button to return to the **Image Settings** page.

To rename a preset:

1. In the **Preset Name** column of the Input Presets list (**1**) or User Presets list (**5**), double-click a **Preset Name**.
2. Change the name as desired.
3. Press the <**Enter**> key to save the new name.

To recall a preset:

1. From the Input Presets list (**1**) or the User Presets list (**5**), select the desired preset.
2. Click the **Recall Preset** button (**3** or **7**) in the same panel as the selected preset. The **Presets** dialog box opens.
3. Click the **Recall** button to recall the preset. Click the **Cancel** button to return to the **Image Settings** page.

To clear a preset:

1. From the Input Presets list (**1**) or the User Presets list (**5**), select the desired preset.
2. Click the **Clear** button (**4** or **8**). The **Presets** dialog box opens.
3. Click the **Clear** button to erase saved data. Click the **Cancel** button to return to the **Image Settings** page.

Size and Position Page

The **Size and Position** page provides three methods of adjusting image output size and position: graphically, numerically, or automatically with Auto-Image. Click the **Size and Position** icon (see [figure 58](#), ⑤, on page 88) on the **Global Navigation Bar** to open the **Size and Position** page.

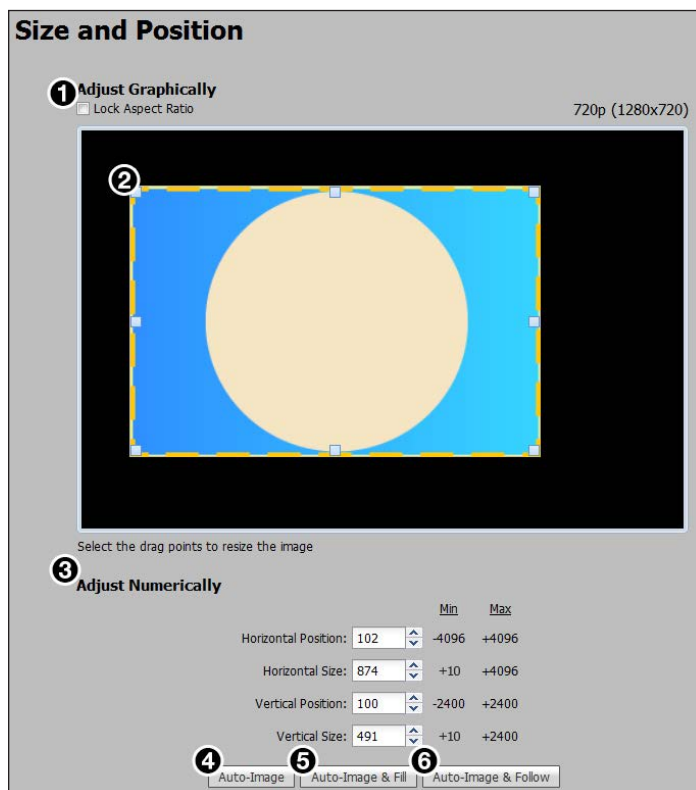

Figure 68. Size and Position Page

To adjust the size and position graphically:

If desired, click the **Lock Aspect Ratio** checkbox (see [figure 68](#), ①) to constrain proportions.

1. Click and drag the drag points of the sample image (②) to resize the image within the designated space (defined by the black area in [figure 68](#)).
2. Click anywhere inside the sample image (see the blue rectangle with a circle inside in [figure 68](#)) and drag it anywhere within the designated space to reposition the image.

To adjust the size and position numerically:

1. Enter a value or click the **Up** or **Down** arrow in the **Horizontal Size** and **Vertical Size** fields (③).
2. Enter a value or click the **Up** or **Down** arrow in the **Horizontal Position** and **Vertical Position** fields (③).

To adjust the size and position automatically:

To automatically adjust these settings, perform one of the following (see [Auto-Image](#) on page 30 for more details on Auto-Image settings):

- Click the **Auto-Image** button (④) to perform a one-time Auto-Image.
- Click the **Auto-Image & Fill** button (⑤) to perform a one-time Auto-Image and fill the entire video output (ignores aspect ratio settings).
- Click the **Auto-Image & Follow** button (⑥) to perform a one-time Auto-Image and to maintain the aspect ratio of the input signal (ignores aspect ratio settings).

Audio Configuration Page

From the **Audio Configuration** page, audio inputs and outputs are configured and mixed. Click the **Audio Config** icon (see [figure 58](#), **6**, on page 88) on the **Global Navigation Bar** to open this page. There are four tabs for adjusting program and microphone inputs, mixing inputs, and configuring outputs.

Configuring the audio in order of the tabs from left to right helps ensure proper setup of input and output levels as well as mix and listening levels.

Configuration overview

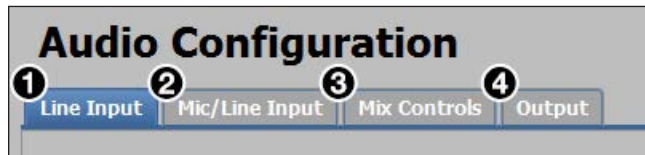

Figure 69. Audio Configuration Tabs

1. From the **Line Input** tab (see [figure 69](#), **1**), set audio input formats and set the input gain at optimal settings.
 - a. Set the audio format of each input (see [Audio format](#) on the next page).
 - b. Set the input gain for analog inputs (see [Input gain](#) on page 100).
2. From the **Mic/Line Input** tab (**2**), set the mic gain at optimal settings.
 - a. If necessary, apply phantom power to the applicable microphone inputs (see [Phantom power](#) on page 102).
 - b. Set the microphone input gain (see [Mic/line gain](#) on page 102).
 - c. If desired, apply a high pass filter to the microphone inputs (see [High pass filter](#) on page 102).
 - d. If desired, enable ducking for the microphone inputs (see [Ducking parameters](#) on page 103).
3. After the line input gain and mic gain are properly set, mix the audio levels and set tone levels from the **Mix Controls** tab (**3**). If the results from this step are satisfactory, skip steps 4 as no other settings need to be adjusted.
 - a. Set the mic mix levels (see [Mic mix levels](#) on page 105).
 - b. Set the listening volume of the microphone inputs (see [Mic volume](#) on page 105).
 - c. Set the listening volume of the program audio (see [Program volume](#) on page 106).
 - d. Set the bass and treble levels for the program material (see [Bass and treble](#) on page 107).
4. If necessary, set output limiters, mix options, or volume from the **Output** tab (**4**).
 - a. If desired, apply an output limiter to the desired outputs (see [Limiters](#) on page 109).
 - b. Set mix options of the output (see [Mix options](#) on page 109).
 - c. Set the output volume (see [Output gain](#) on page 111).

Line input configuration

The Line Input tab contains options to set the audio input format for each input and adjust the input gain for analog inputs.



Figure 70. Line Input Tab (IN1608)

Audio format

The audio input format specifies whether the audio input is analog, digital, or not to be sent to the output.

NOTE: Multi-channel audio does not include microphone inputs or audio processing when it is sent to the output. It is also unaffected by volume control and does not show meter activity.

For inputs 1 and 2, available formats include:

- **None** — Audio is not sent to the output. This option sets “No Audio” EDID.
- **Analog** — Analog audio is sent to the output. This options sets “No Audio” EDID.

For all other inputs, available formats include:

- **None** — Audio is not sent to the output. This option sets “No Audio” EDID.
- **Analog** — Analog audio from the corresponding analog input is sent to the output. This options sets “No Audio” EDID.
- **LPCM-2Ch** — The digital input is configured to receive 2-channel LPCM audio. This option sets 2Ch audio EDID.
- **Multi-Ch** — The digital input is configured to receive multi-channel audio. If multi-channel audio is not available, 2-channel LPCM audio is passed to the digital outputs. This option sets Multi-Ch audio EDID.
- **LPCM-2Ch Auto** — The digital input is configured to receive 2-channel LPCM audio. If 2-channel LPCM audio is not detected, the input switches to the corresponding analog input to send to the output. This option sets 2Ch audio EDID.
- **Multi-Ch Auto** — The digital input is configured to receive multi-channel audio, but will pass 2-channel LPCM if multi-channel audio is not available. If neither multi-channel audio nor 2-channel LPCM audio is detected, the input switches to the corresponding analog input to send to the output. This option sets Multi-Ch audio EDID.

To select an audio format:

1. Click the **Line Input** tab (see [figure 70](#), **1**, on the previous page).
2. From the **Audio Format** drop-down menu (**2**) of the each input, select the desired format.

Input gain

The **Input Gain** fader can apply to analog or digital gain depending on the input. It has a gain range of -18 dB to +24 dB. Adjustments are applied in 0.1 dB increments. The default setting is 0.0 dB. The current level for each input is displayed to the right of the corresponding **Audio Format** drop-down menu.

To adjust the fader level:

1. Click the **Line Input** tab (**1**).
2. In the **AV Controls** panel (see [figure 57](#), **2**, on page 86), select the desired input.

NOTES:

- Analog input gain adjustment applies only to analog signals. The **Input Gain** fader is available for analog gain only when the audio format is set to **Analog**, **LPCM-2Ch Auto**, or **Multi-Ch Auto**.
- LPCM-2Ch input gain adjustment applies only to digital signals. The **Input Gain** fader is available for digital gain only when the audio format is set to **LPCM-2Ch**, **LPCM-2Ch Auto**, or **Multi-Ch Auto**.

3. If the audio input format is set to **LPCM-2Ch Auto** or **Multi-Ch Auto**, click the **Analog** radio button to adjust analog input gain or click the **LPCM-2Ch** radio button to adjust digital input gain (see [figure 70](#), **3**).
4. Adjust the level using any of the following methods (**4**):
 - Click and drag the fader handle to the desired level.
 - Press the **<Up Arrow>** or **<Down Arrow>** key to respectively increase or decrease the level in 1 dB increments (PCS only).
 - Press the **<Page Up>** or **<Page Down>** key to respectively increase or decrease the level in 10 dB increments (PCS only).
 - Click in the level text field below the fader and enter a new value. Then, press the **<Enter>** or **<Tab>** key to apply the change.
 - Click the **Up** or **Down** arrow button to the right of the level text field to respectively increase or decrease the level in 0.1 dB increments.

When possible, set the analog input gain using the intended input source device and typical source material (program material). Use pink noise when the source material is not available.

To optimize input gain with program material:

1. Click the **Line Input** tab (**1**).
2. For the web pages, select the **Enable Meters** checkbox (**5**).

NOTE: Meters are automatically enabled on the PCS.

3. Set the level so that the meters reach approximately -15 dBFS to -12 dBFS, with peaks at approximately -6 dBFS. This setting provides enough headroom to accommodate transients or unanticipated loud events in the program material to avoid possible clipping.

To optimize input gain with pink noise:

1. Click the **Line Input** tab (see [figure 70](#), **1** on page 99).
 2. For the web pages only, select the **Enable Meters** checkbox (see [figure 71](#), **5**).
- NOTE:** Meters are automatically enabled on the PCS.
3. Set the input gain so the meters read approximately -20 dBFS.
 4. If the audio source has an output level setting control, set the output of the player to the maximum or 0 dB of attenuation.
 5. If the maximum output setting provides gain, adjust the gain slightly lower than the maximum setting.
 6. If the pink noise is being generated by a signal generator, set the output to -10 dBu.

Microphone audio input configuration

There are two mic/line inputs for the IN1606 and IN1608 series. The **Mic/Line Input** tab contains options to apply phantom power or a high pass filter to the microphone inputs, set ducking parameters, or adjust input gain on the microphone inputs.

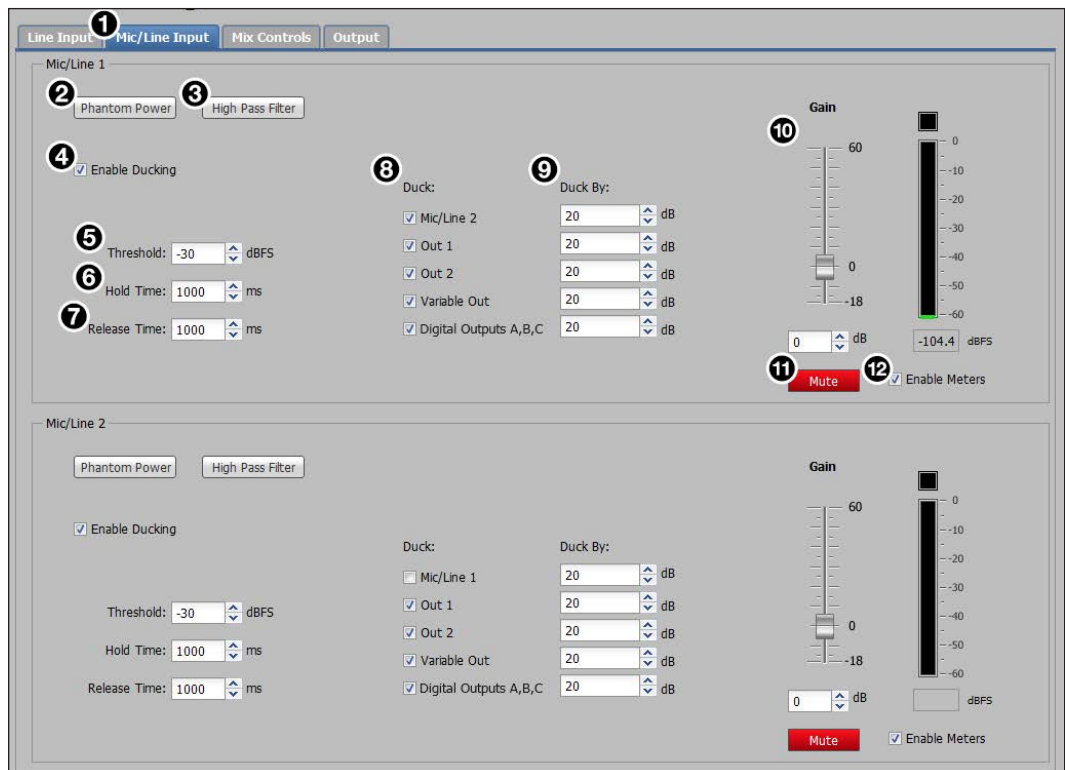

Figure 71. Mic/Line Input Tab

NOTE: Features for mic/line 1 and 2 are the same.

Phantom power

Phantom power adds +48 VDC to the mic/line input. The default level for the microphone input is 0 dB, muted. Having the input muted before plugging in a microphone and especially before turning on phantom power is recommended.

ATTENTION:

- Condenser microphones require +48 V phantom power. Dynamic microphones do not require power. Never enable phantom power with an unbalanced dynamic microphone connected. Doing so may damage the microphone.
- Les microphones électrostatiques nécessitent une +48 V alimentation fantôme. Les microphones dynamiques n'ont pas besoin d'alimentation. Ne réglez jamais l'alimentation fantôme avec un microphone dynamique asymétrique. Cela pourrait endommager le micro.
- For condenser microphones, verify it will safely operate at +48 VDC.
- Pour les microphones électrostatiques, vérifiez qu'ils fonctionnent bien à +48 Vcc.
- When a line level source is connected, be certain the +48 V phantom power is off.
- Lorsqu'une source de niveau ligne est connectée, soyez certain que l'alimentation fantôme +48 V est débranchée.

To enable or disable phantom power:

1. Click the **Mic/Line Input** tab (see [figure 71](#), ❶, on the previous page).
2. In the **Mic/Line** input panel for the desired microphone input, click the **Phantom Power** button (❷). The button turns blue when enabled.

High pass filter

The high pass filter allows all frequencies at or above 100 Hz to pass unattenuated. All frequencies below 100 Hz are attenuated at 6 dB/octave to reduce background noise.

To apply or remove a high pass filter:

1. Click the **Mic/Line** tab (❶).
2. In the **Mic/Line** input panel for the desired microphone input, click the **High Pass Filter** button (❸). The button turns blue when enabled.

Mic/line gain

The mic/line **Gain** fader has a gain range of -18 dB to +60 dB. Adjustments increase or decrease in 0.1 dB increments. The default setting is 0.0 dB.

The gain range accommodates a line level signal, typically from line level source devices or a wireless microphone receiver with a line level output, or a mic level signal from dynamic or condenser microphones.

To adjust the mic/line Gain fader:

1. Click the **Mic/Line Input** tab (❶).
2. Adjust the level using any of the following methods (❷):
 - Click and drag the fader handle to the desired level.
 - Press the **<Up Arrow>** or **<Down Arrow>** key to respectively increase or decrease the level in 1 dB increments (PCS only).
 - Press the **<Page Up>** or **<Page Down>** key to respectively increase or decrease the level in 10 dB increments (PCS only).
 - Click in the level text field below the fader and enter a new value. Then, press the **<Enter>** or **<Tab>** key to apply the change.

- Click the **Up** or **Down** arrow button to the right of the level text field to respectively increase or decrease the level in 0.1 dB increments.
3. To mute the mic/line gain, click the **Mute** button below the mic/line **Gain** fader (see **figure 71**, **11**, on page 101).

To optimize the mic/line gain on each microphone input:

1. Connect the desired microphone and route the mic/line input to the desired output.
2. If needed, click the **Phantom Power** button (see **Phantom power** on the previous page).
3. Set the mic/line **Gain** fader to 0 dB.
4. If the mic/line input is muted (the **Mute** button is red when the audio is muted), click the **Mute** button (**11**) to unmute the mic/line input.
5. For web pages, select the **Enable Meters** checkbox (**12**).

NOTE: Meters are automatically enabled in the PCS.

6. While speaking into a connected microphone, adjust the mic/line **Gain** fader until the mic/line audio input is clearly audible. Voice levels at microphone inputs can vary significantly, so gain and meter level readings may vary. Aim to have the meter averaging -20 dBFS to -15 dBFS to accommodate normal variances in voice intensity.

Ducking parameters

Ducking lowers the level of microphone or program material (based on a source signal from another microphone) for the duration of the signal that is present at the source microphone. It restores the original level after the source signal ceases and after the hold and release times are met. This is useful when:

- Program material must be attenuated in order to accentuate the voice of a narrator.
- One microphone is used by a chairman or master of ceremonies and must have priority over other microphones and program material.
- A paging microphone must attenuate all other signals.

To apply ducking for microphone inputs:

1. Click the **Mic/Line Input** tab (**1**).
2. From the desired **Mic/Line** input panel, select the **Enable Ducking** checkbox (**4**). The following ducking options become available:
 - **Threshold** — Sets the input signal level in dB that the ducking source must exceed before ducking begins. The default is -30 dBFS.
 - **Hold time** — Determines the time in milliseconds after a ducking source signal drops below the threshold before ducking ceases. The default value is 1000 ms.
 - **Release time** — Determines how long in milliseconds the ducking targets take to restore signal levels after the ducking source level is below the threshold and the hold time is met.
 - **Duck (targets)** — Shows all potential targets to be attenuated when ducking is enabled.
 - **Duck by (attenuation)** — Attenuates the corresponding duck target in dB.
3. In the **Threshold** field (**5**), adjust the value by one of the following methods:
 - Enter a value in the **Threshold** field and press the **<Enter>** or **<Tab>** key.
 - Click the **Up** or **Down** arrow buttons.

If ducking does not occur quickly enough to avoid loss of speech or program material from the ducking source, decrease this setting. If ducking occurs too soon, allowing background noise to trigger ducking, increase the setting.

4. In the **Hold Time** field (see [figure 71](#), **6**, on page 101) adjust the value by one of the following methods:
 - Enter a value in the **Hold Time** field and press the <Enter> or <Tab> key.
 - Click the **Up** or **Down** arrow buttons. The default value is 1000 ms.
 5. In the **Release Time** field (**7**), adjust the value by one of the following methods:
 - Enter a value in the **Release Time** field and press the <Enter> or <Tab> key.
 - Click the **Up** or **Down** arrow buttons.
 6. In the list of **Duck (target)** checkboxes (**8**), select the targets to attenuate when the threshold is met. Only selected inputs are ducked.
- NOTE:** Only one mic input can be selected as a duck target at a time.
7. For those targets checked in step 6, adjust the adjacent **Duck By** field (**9**) in one of the following methods:
 - Enter a value in the **Duck By** field and press the <Enter> or <Tab> key.
 - Click the **Up** or **Down** arrow buttons. The default is 20 dB. If additional attenuation of a target is required, increase this value.

Audio mix configuration

After the audio inputs have been properly configured, select the **Mix Controls** tab (see [figure 72](#), **1**) to mix microphone levels, create a mix of the microphone and program volume, and set bass and treble settings.

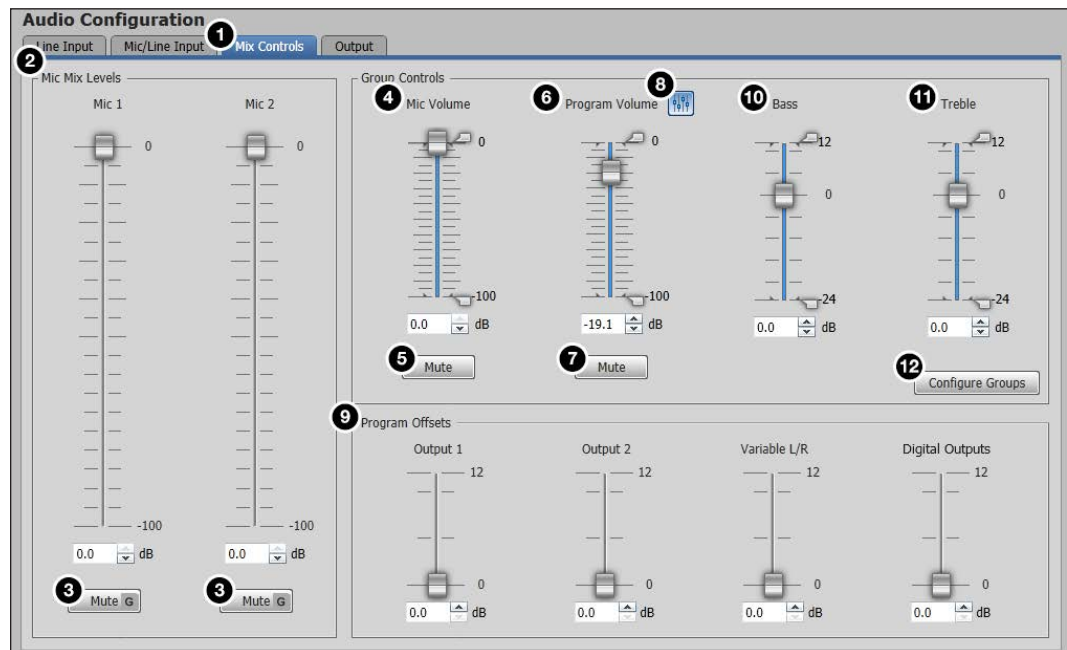

Figure 72. Mix Controls Tab

Mic mix levels

Mic mix levels adjust the individual mic levels to create a proper blend (mix) of the two microphones. Adjust the **Mic 1** or **Mic 2** fader to adjust the desired mic/line level.

To adjust the mic mix levels:

1. Click the **Mix Controls** tab (see **figure 72, ①**, on page 104).
2. Adjust the level using any of the following methods (**②**):
 - Click and drag the fader handle to the desired level.
 - Click the fader handle and press the **<Up Arrow>** or **<Down Arrow>** key to respectively increase or decrease the level in 1 dB increments (PCS only).
 - Click the fader handle and press the **<Page Up>** or **<Page Down>** key to respectively increase or decrease the level in 10 dB increments (PCS only).
 - Click in the level text field below the fader and enter a new value. Then, press the **<Enter>** or **<Tab>** key to apply the change.
 - Click the **Up** or **Down** arrow button to the right of the level text field to respectively increase or decrease the level in 0.1 dB increments.
3. To mute the mic/line gain, click the **Mute** button (**③**), below the corresponding **Mic** fader.

Mic volume

Mic volume adjusts the listening level of the mic mix (the blend of the individual microphones) while maintaining the relative individual levels (see **Mic mix levels** on the previous page). The **Mic Volume** fader has a range of -100 dB to 0 dB. It also includes soft limit handles to adjust the minimum and maximum allowable range (highlighted in blue).

To adjust the mic volume:

1. Click the **Mix Controls** tab (see **figure 72, ①**, on the previous page).
2. Adjust the level using any of the following methods (**④**):
 - Click and drag the fader handle to the desired level.
 - Click the fader handle and press the **<Up Arrow>** or **<Down Arrow>** key to respectively increase or decrease the level in 1 dB increments (PCS only).
 - Click the fader handle and press the **<Page Up>** or **<Page Down>** key to respectively increase or decrease the level in 10 dB increments (PCS only).
 - Click in the level text field below the fader and enter a new value. Then, press the **<Enter>** or **<Tab>** key to apply the change.
 - Click the **Up** or **Down** arrow button to the right of the level text field to respectively increase or decrease the level in 0.1 dB increments.
3. If desired for the **Mic Volume** fader, click and drag the minimum and maximum soft limits to define new minimum and maximum values within the original range.
4. To mute the microphone inputs, click the **Mute** button (**⑤**) below the **Mic Volume** fader.

Program volume

Program volume adjusts the listening level of the program source, independent of the mic volume. The **Program Volume** fader has a range of -100 dB to 0 dB. It also includes soft limit handles to adjust the minimum and maximum allowable range (highlighted in blue).

NOTE: Listening to the audio throughout the process of setting the program volume may be required for setting a nominal output level.

To adjust the program volume:

1. Click the **Mix Controls** tab (see **figure 72**, **1**, on page 104).
2. Adjust the level using any of the following methods (**6**):
 - Click and drag the fader handle to the desired level.
 - Click the fader handle and press the **<Up Arrow>** or **<Down Arrow>** key to respectively increase or decrease the level in 1 dB increments (PCS only).
 - Click the fader handle and press the **<Page Up>** or **<Page Down>** key to respectively increase or decrease the level in 10 dB increments (PCS only).
 - Click in the level text field below the fader and enter a new value. Then, press the **<Enter>** or **<Tab>** key to apply the change.
 - Click the **Up** or **Down** arrow button to the right of the level text field to respectively increase or decrease the level in 0.1 dB increments.
3. If desired for the **Program Volume** fader, click and drag the minimum and maximum soft limits to define new minimum and maximum values within the original range.
4. To mute the program volume, click the **Mute** button (**7**) below the **Program Volume** fader.

To adjust individual output gain:

1. Click the **Program Volume Offsets** button (**8**). The **Program Offsets** panel appears below the **Group Controls** panel.
2. Adjust the level of each desired output in any of the following methods (**9**):
 - Click and drag the fader handle to the desired level.
 - Click the fader handle and press the **<Up Arrow>** or **<Down Arrow>** key to respectively increase or decrease the level in 1 dB increments (PCS only).
 - Click the fader handle and press the **<Page Up>** or **<Page Down>** key to respectively increase or decrease the level in 10 dB increments (PCS only).
 - Click in the level text field below the fader and enter a new value. Then, press the **<Enter>** or **<Tab>** key to apply the change.
 - Click the **Up** or **Down** arrow button to the right of the level text field to respectively increase or decrease the level in 0.1 dB increments.

To optimize the program volume:

1. With the amplifier turned off, connect the Variable output of the scaler to an amplifier of appropriate size for the room and the speakers.
2. Set the amplifier input level to a moderate level (for example, the twelve o'clock position on the amplifier dial). For IN1608 amplifier and IN1608 IPCP models, the amplifier input level setting is already set.

NOTE: The twelve o'clock position on an amplifier input level is generally a moderate level. This allows for the maximum signal to noise ratio and is easily repeatable. The actual value of the amplifier input level will vary on each amplifier. While most amplifiers have a maximum input of +4 dBu, attenuating the amplifier input sensitivity by 12-17 dB will generally allow for maximum output from the scaler.

3. Connect the speakers to the amplifier, assuring that polarity is not reversed.
4. Set the program volume to full attenuation.
5. Set the output volume to 100% (default).
6. Turn on the amplifier.
7. Play program material and adjust program volume to a reasonably loud yet tolerable level. Verify that the amplifier is not clipping.
8. If desired, set the upper soft limit on the program volume to set the maximum allowable level. This may be 6 or 12 dB above the current level (reasonably loud), or a value that is determined to be the loudest level allowable for the room. Verify that the amplifier is not clipping.
9. If desired, set a minimum allowable level by setting the lower soft limit.
10. Set the mic volume to an appropriate level relative to program volume.

Bass and treble

Also known as shelving or tone controls, the bass and treble faders provide the ability to cut or boost levels. Both faders have a range of -24 dB to +12 dB. They also includes soft limit handles to adjust the minimum and maximum allowable range (highlighted in blue). The bass tone control corner frequency is 100 Hz. The treble tone control corner frequency is 8 kHz.

To adjust the bass or treble:

1. Click the **Mix Controls** tab (see [figure 72](#), **1**, on page 104).
2. Adjust the level using any of the following methods (see [figures 73-77](#), **3**), on the next two pages):
 - Click and drag the fader handle to the desired level.
 - Click the fader handle and press the **<Up Arrow>** or **<Down Arrow>** key to respectively increase or decrease the level in 1 dB increments (PCS only).
 - Click the fader handle and press the **<Page Up>** or **<Page Down>** key to respectively increase or decrease the level in 10 dB increments (PCS only).
 - Click in the level text field below the fader and enter a new value. Then, press the **<Enter>** or **<Tab>** key to apply the change.
 - Click the **Up** or **Down** arrow button to the right of the level text field to respectively increase or decrease the level in 0.1 dB increments.
3. If desired for the **Bass** or **Treble** fader, click and drag the minimum and maximum soft limits to define new minimum and maximum values within the original range.

Output configuration

The Output tab contains options to apply a limiter, set mix options, or adjust output gain. Each output has a section containing these options, but each section may appear slightly different depending on the scaler model.

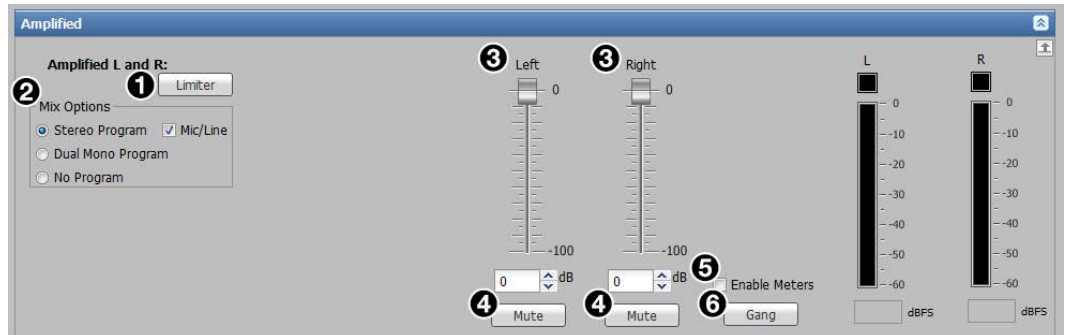

Figure 73. Amplified Audio Output Section (SA Models)

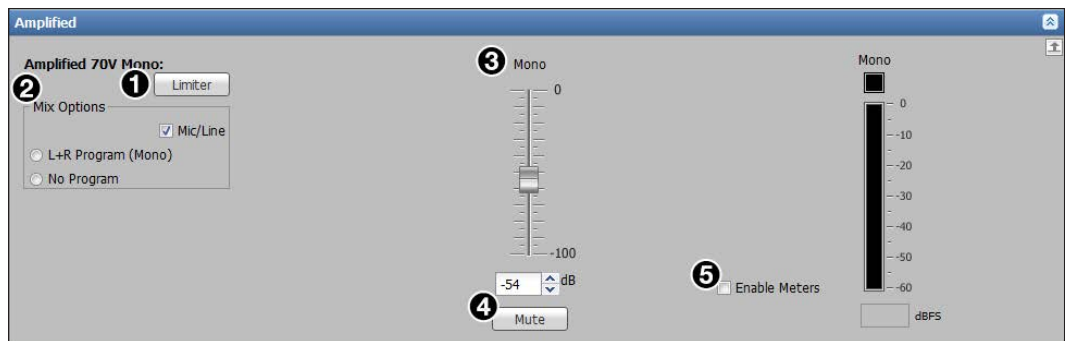

Figure 74. Amplified Audio Output Section (MA Models)

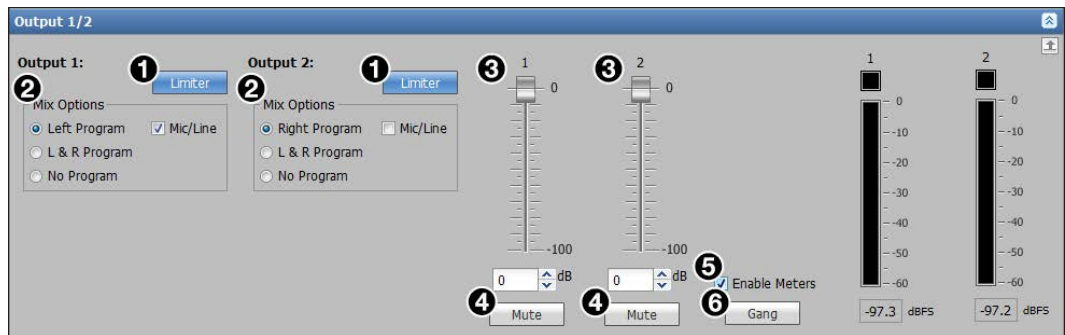

Figure 75. Analog Audio Output 1/2 Section

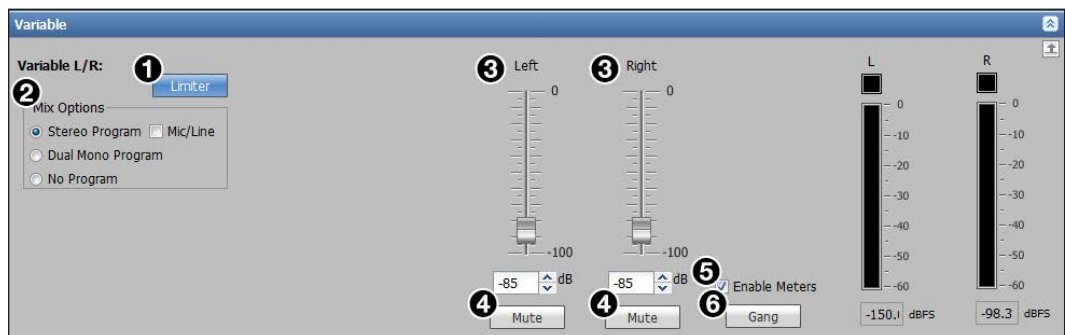

Figure 76. Variable Analog Audio Output Section

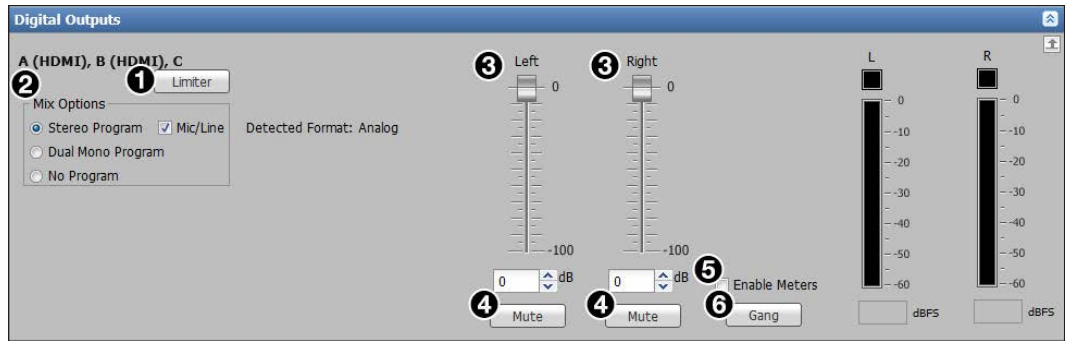

Figure 77. Digital Audio Output Section (IN1608 Series)

The digital output section displays the detected audio format sent to the HDMI or twisted pair output (see [Audio format](#) on page 99).

NOTE: If the detected format is Multi-Ch audio, the **Left** and **Right** faders and meters are not applicable.

Limiters

The output limiters restrict the input signal level by compressing its dynamic range when exceeding a specified threshold. They are most commonly used to prevent clipping, protecting a system against component or speaker damage. They are enabled by default, which is the recommended setting for most configurations.

When a limiter is enabled, the following are set:

- **Threshold** — Activates or deactivates the limiter (subject to attack or release time) after the signal level exceeds or drops below -0.1 dBFS.
- **Attack time** — Activates the limiter after the signal level reaches or exceeds the threshold level for 2.0 ms.
- **Release time** — Restores the output signal level to normal (unprocessed) levels when the signal level remains below the threshold level for 100 ms.
- **Ratio** — Reduces the signal level at a 100:1 ratio when the limiter is activated.
- **Soft knee** — Smooths and softens the transition from unprocessed to processed output levels.

To enable or disable a limiter on an output:

1. Click the **Output** tab (see [figure 69](#), [4](#), on page 98).
2. For the desired output, click the **Limiter** button (see [figures 73-77](#), [1](#), on pages 108 and 109) in the appropriate output section.

Mix options

Output mix options determine what audio is output. Options vary depending on device model and output connector.

For amplified outputs (IN1608 amplifier and IN1608 IPCP models only):

1. Click the **Output** tab (see [figure 69](#), [4](#)).
2. If desired, deselect the **Mic/Line** checkbox (see [figures 73-74](#), [2](#), on the previous page) to not include the mic/line inputs in the amplified output (this is selected by default).

3. In the **Mix Options** panel (see **figures 73-74, 2**, on page 108), click the desired radio button. The IN1608 amplifier models have different options based on the type of amplified audio output connector.

For stereo models, the mix options include the following:

- **Stereo Program** — Outputs program audio as left and right stereo.
- **Dual Mono Program** — Sums Left and Right program audio and outputs it on each channel.
- **No Program** — Mutes program audio.

For mono models, the mix options include the following:

- **L + R Program (Mono)** — Sums left and right program audio on the output.
- **No Program** — Mutes program audio.

For analog outputs 1 and 2:

1. Click the **Output** tab (see **figure 69, 4**, on page 98).
2. If desired, deselect the **Mic/Line** checkbox (see **figure 77, 2** on the previous page) to not include the mic/line inputs in the amplified output (this is selected by default).
3. In each **Mix Options** panel (see **figure 76, 2**, on page 108) click the desired radio button. The two outputs can be mixed together (see the table below).

Output 1	Output 2	Result
Left Program	Right Program	Output 1 and 2 act as a stereo pair (default).
L+R Program	L+R Program	L and R program audio are summed on each output. They act as unique, independent outputs with or without mic.
No Program	No Program	No program audio. Output 1 and 2 are treated as unique, independent outputs with or without mic.

For the variable analog output:

1. Click the **Output** tab (see **figure 69, 4**, on page 98).
2. If desired, deselect the **Mic/Line** checkbox in the **Mix Options** panel (see **figure 77, 2** on the previous page) to not include the mic/line inputs in the amplified output (this is selected by default).
3. In the **Mix Options** panel, click the desired radio button:
 - **Stereo Program** — Outputs program audio as left and right stereo.
 - **Dual Mono Program** — Sums left and right program audio and outputs it on each channel.
 - **No Program** — Mutes program audio.

For digital outputs (HDMI A, HDMI B, and Out C for IN1608 Series):

1. Click the **Output** tab (see **figure 69, 4**, on page 98).
2. If desired, click the **Mic/Line** checkbox in the **Mix Options** panel (see **figure 77, 2**, on the previous page) to include the mic/line inputs in the output.
3. In the **Mix Options** panel, click the desired radio button:
 - **Stereo Program** — Outputs program audio as left and right stereo.
 - **Dual Mono Program** — Sums left and right program audio and outputs it on each channel.
 - **No Program** — Mutes program audio.

Output gain

Each output has a gain fader for output gain adjustment.

NOTE: The detected program audio format can be None, AnaLog, LPCM-2Ch, or Multi-Ch.

To adjust the gain fader:

1. Click the **Output** tab (see [figure 69](#), [4](#), on page 98).
2. If the section has multiple faders, click the **Gang** button (see [figure 73](#) and [75-77](#), [6](#), on pages 108-109) to constrain the proportions between fader levels.
3. Adjust the level using any of the following methods (see [figures 73-77](#), [3](#)):
 - Click and drag the fader handle to the desired level.
 - Click the fader handle and press the **<Up Arrow>** or **<Down Arrow>** key to respectively increase or decrease the level in 1 dB increments (PCS only).
 - Click the fader handle and press the **<Page Up>** or **<Page Down>** key to respectively increase or decrease the level in 10 dB increments (PCS only).
 - Click in the level text field below the fader and enter a new value. Then, press the **<Enter>** or **<Tab>** key to apply the change.
 - Click the **Up** or **Down** arrow button to the right of the level text field to respectively increase or decrease the level in 0.1 dB increments.
4. To mute an output, click the **Mute** button ([4](#)) below the desired fader.

To optimize the output gain:

1. In the desired output section of the web page, click the **Enable Meters** checkbox ([5](#)).

NOTE: Meters are automatically enabled on the PCS.

2. Set the output gain to 0 dB.
3. With program material (or pink noise) present on the input, adjust the output volume until the meters maintain a level just below clipping.

Group masters

The IN1606 and IN1608 Series include eight pre-configured group masters that allow multiple group members to be adjusted using a single group master control (see the table below for a description of each group master and the associated group members).

Group masters provide a convenient way to adjust multiple controls simultaneously.

They can also be adjusted through a control system using SIS commands (see [Audio Configuration Commands](#) on page 57).

Group Master	Group Description	Group Controls Panel Association	Control Type	Possible Members
1	Program Volume	Program Volume fader on the Mix Controls screen	Post-switcher gain	Amplified output Analog output 1 Analog output 2 Variable analog output Digital outputs A, B, and C
2	Program Mute	Program Volume Mute button on the Mix Controls screen	Post-switcher mute	Amplified output Analog output 1 Analog output 2 Variable analog output Digital outputs A, B, and C
3	Mic Volume	Mic Volume fader on the Mix Controls screen	Pre-mixer gain	Mic/Line 1 Mic/Line 2
4	Mic Mute	Mic Volume Mute button on the Mix Controls screen	Pre-mixer mute	Mic/Line 1 Mic/Line 2
5	Bass Control	Bass fader on the Mix Controls screen	Bass gain	Amplified output Analog output 1 Analog output 2 Variable analog output Digital outputs A, B, and C
6	Treble Control	Treble fader on the Mix Controls screen	Treble gain	Amplified output Analog output 1 Analog output 2 Variable analog output Digital outputs A, B, and C
7	Output Mute	Audio Mute button on the AV Controls panel	Output mute	Amplified output Analog output 1 Analog output 2 Variable analog output Digital outputs A, B, and C
8	Output Volume	Front panel volume knob when set from the Configure Groups dialog box	Output volume	Amplified output Analog output 1 Analog output 2 Variable analog output Digital outputs A, B, and C

KEY:

- Amplified output is for IN1608 amplifier and IN1608 IPCP models only.
- Digital output C is for IN1608 Series models only.
- By default, all possible group members are selected for groups 1-7.
- The default selected group members for group 8 are amplified output (IN1608 amplifier and IN1608 IPCP models only) and variable analog output.

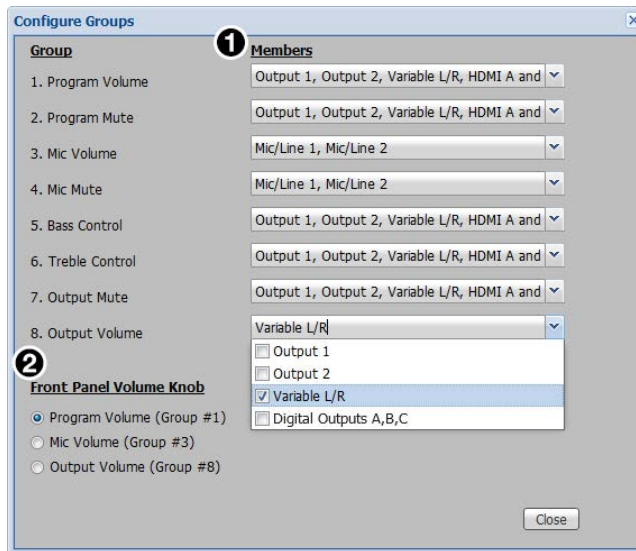

Figure 78. Configure Groups Dialog Box

To configure the groups:

1. Click the **Mix Controls** tab (see [figure 72](#), **1**, on page 104).
2. In the Group Controls panel of the Mix Controls screen, click the **Configure Groups** button (**12**). The Configure Groups dialog box opens.
3. For the desired group master, click the corresponding drop-down menu (see [figure 78](#), **1**) to display a list of available group members.

When changes are made to the associated control in the software, only the selected group members are affected (see the [table](#) on the previous page).

To assign a volume control to the front panel volume knob:

1. Click the **Mix Controls** tab (see [figure 73](#), **1**).
2. In the Group Controls panel, click the **Configure Groups** button (**12**). The Configure Groups dialog box opens.
3. From the Front Panel Volume Knob list (see [figure 78](#), **2**), select the desired volume control the front panel volume knob adjusts. The available options are:
 - **Program Volume (Group #1)** — Adjusts the program audio (default).
 - **Mic Volume (Group #3)** — Adjusts microphone volume.
 - **Output Volume (Group #8)** — Adjusts the output volume.

Group members

Group members are individual controls that comprise the group master. They can be controlled individually, allowing for relative levels between members to be adjusted.

NOTE: Individual members of a mute group master that are muted outside of the group master remain muted regardless of the current group master state.

Group controls

When grouped, gain control members move together at relative levels. If one member reaches its limit, it retains that position while the other members continue to travel. When the grouped members travel in the reverse direction, the member that was at its limit reverts to its position relative to the other members.

When grouped, mute control members update to indicate they are part of a group. Group members can be individually muted as well. When grouped members are individually muted, they are exempt from the setting of the group master.

Preset Management Page

The Preset Management page gives access to input and user presets. Click the **Preset Management** icon (see [figure 58](#), ⑦, on page 88) on the Global Navigation Bar to open the Preset Management page.

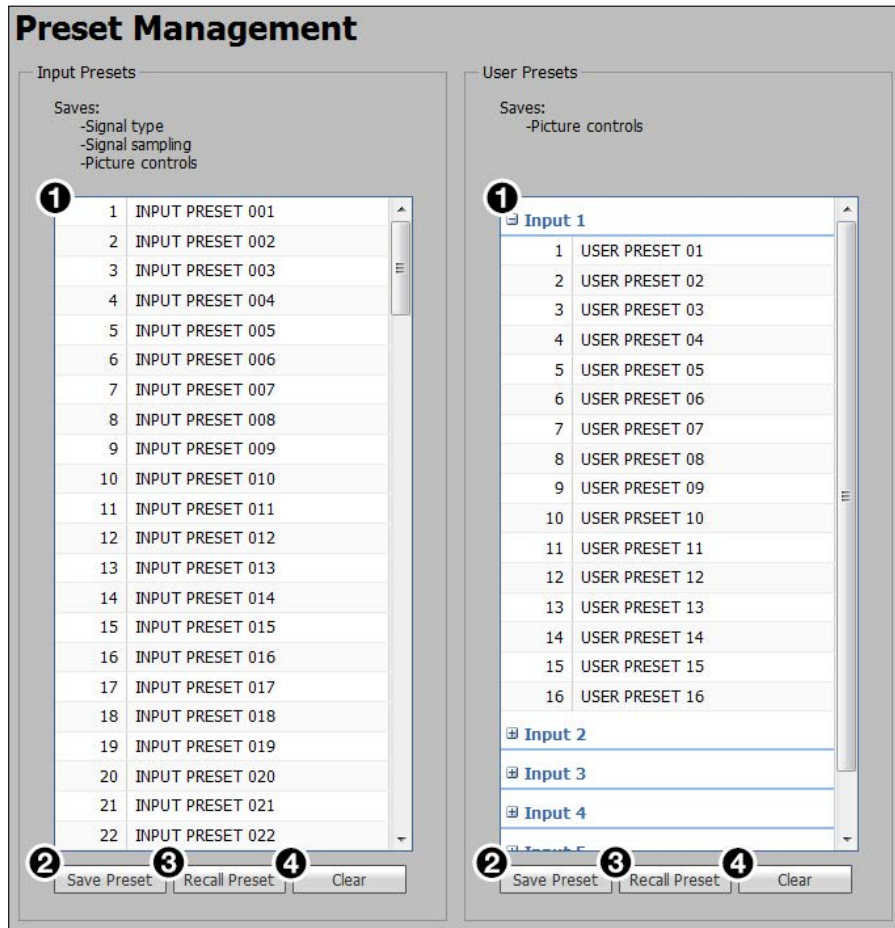

Figure 79. Preset Management Page

To save a preset:

1. Select the input preset or user preset (see [figure 79](#), ①) to store the current configuration.
2. Click the **Save Preset** button (②) located in the same **Input Presets** or **User Presets** panel. If the selected preset already has stored information on it, a confirmation dialog box opens.
3. Click the **Overwrite** button to erase the previous data and save the new settings or click the **Cancel** button to return to the Preset Management page.

To recall a preset:

1. Select the input preset or user preset (see [figure 79](#), ①, on the previous page) to be recalled.
2. Click the **Recall Preset** button (③) located in the same **Input Presets** or **User Presets** panel. A confirmation dialog box opens.
3. Click the **Recall** button to recall the preset or click the **Cancel** button to return to the Preset Management page.

To clear a preset:

1. Select the input preset or user preset (see [figure 79](#), **1**) on the previous page) to be cleared.
2. Click the **Clear** button (**4**) located in the same section of the screen. A confirmation dialog box opens.
3. Click the **Clear** button to erase saved data or click the **Cancel** button to return to the Preset Management page.

To rename a preset:

1. Double-click a **Preset Name** or right-click a **Preset Name** (**1**) and select **Rename**.
2. Enter a new preset name and press the <Enter> key.

Device Settings Page

The Device Settings page allows configuration of screen saver settings, auto switch modes, HDCP notifications, video and sync muting, on-screen display timeout, and HDCP modes. Click the **Device Settings** icon (see [figure 58](#), **8**, on page 88) on the Global Navigation Bar to open the Device Settings page.

The screenshot displays the 'Device Settings' page with six numbered callouts pointing to specific settings:

- 1 Screen Saver**: Shows options for 'Displays when no input signal is detected: Black, Blue with On Screen Display (OSD) Bug, Custom'. A color palette is visible with 'RGB Color Value: 99CC00' and an 'Apply' button. A checkbox for 'Disable Sync After: 60 seconds (0-500)' is checked.
- 2 HDCP Notification**: 'Select display color when sending HDCP content on a non-compliant display: Black, Green'. 'Green' is selected.
- 3 OSD Input Information**: 'OSD input information displays after every input switch'. 'Enable On Screen Display (OSD)' is checked, and 'Duration On Screen: 3 seconds (1-500)' is set.
- 4 Auto Switch**: 'Enable Auto Switch' is checked. 'Priority to the highest active input number' is selected.
- 5 Mute Video and Sync**: 'This may allow a connected sink to go into a power saving mode.' A 'Mute Video and Sync' button is present.
- 6 HDCP Mode**: 'Follow Input' is selected.

Figure 80. Device Settings Page

Screen Saver panel

When no active video is detected on the selected input, the screen saver mode is activated. The output sync can be disabled after a user-set duration, which allows display devices to go into a low power, standby state.

1. Click one of the radio buttons (see [figure 80](#), **2**) to select a display when the screen saver is enabled.
 - **Black** — Mutes video output to black for a set duration before disabling output sync (default).

- **Blue with On Screen Display (OSD) Bug** — Displays a blue background with a moving OSD message that indicates “<scaler model>: Input <number> No Signal” for a set duration before disabling the output sync.
- **Custom** — Accesses the color selector field, in which you can click on the color to be used on the screen saver. The value of the selected color is displayed in the **RGB Color Value** field, located to the right of the color selector.

Alternatively, enter a color value in the **RGB Color Value** field. This value is then highlighted in the color selector.

After selecting or entering the color, click **Apply** to apply it to the screen.

2. Select a duration to display the screen saver before the output sync is disabled.
 - Select the **Disable Sync After** checkbox to disable the scaler output sync after a set duration without an active input. When selected, the **Duration On Screen** field becomes available.
 - In the **Duration** field, enter a value in the field or click the **Up** and **Down** arrows to specify a duration to wait before disabling output sync during inactivity. The default is to never disable the output sync.

HDCP Notification panel

HDCP notification indicates when HDCP content restrictions prevent a video signal from passing. Select one of the following radio buttons (see [figure 80, ②](#) on the previous page):

- **Black** — Displays a black or muted screen when an encrypted source is sent to a display that is not HDCP-compliant.
- **Green** — Displays a green screen when an encrypted source is displayed on a sink that is not HDCP-compliant (default).

OSD Input Information panel

1. To display input information on the OSD after input selection, select the **Enable On Screen Display (OSD)** checkbox ([③](#)).
2. In the **Duration On Screen** field, enter a value or click the **Up** or **Down** arrow button to set a duration the information is displayed on the OSD menu. The default value is 3.

Auto Switch panel

Auto switch mode automatically switches inputs based on detected input signals.

1. Select the **Enable Auto Switch** checkbox ([④](#)) to enable auto switch mode.
2. Click the radio button of the desired type of auto switch mode from the following:
 - **Priority to the highest active input number** — Automatically switches the input to the highest numbered active input.
 - **Priority to the lowest active input number** — Automatically switches the input to the lowest numbered active input.

Mute Video and Sync panel

Click the **Mute Video and Sync** button ([⑤](#)) to mute the active video and disable sync on the HDMI outputs.

HDCP Mode panel

HDCP mode either follows the encryption status of the selected input or always encrypts the output. However, some sink devices require continuous DVI authentication trials to pass HDCP encrypted content after a power cycle or resuming from sleep mode. Select one of the following radio buttons (see [figure 80](#), [6](#), on page 115):

- **Follow Input** — Encrypts the output only when required by the selected input source.
- **Always Encrypt Output** — Always encrypts the output, regardless of the HDCP status of the selected input source.
- **Follow Input (with continuous DVI trials)** — Encrypts the output only when required by the selected input source. Use this setting when DVI sink devices initially pass HDCP encrypted content, but intermittently display a green HDCP notification screen after a power cycle or resuming from sleep mode.
- **Always Encrypt Output (with continuous DVI trials)** — Always encrypts the output regardless of the HDCP status of the selected input source. Use this setting when DVI sink devices initially pass HDCP encrypted content, but intermittently display a green HDCP notification screen after a power cycle or resuming from sleep mode.
- **Disable Authentication** — Prevents HDCP authentication and encryption.

Hardware Pages

The **Hardware** pages contain unit information and options for device naming, communication settings, updating firmware, executive and power modes, date and time settings, passwords, and reset modes. Click the **Hardware** tab (see [figure 81](#), [1](#)) to open these pages.



Figure 81. Hardware Global Navigation Bar

Unit Information Page

The **Unit Information** page gives a non-configurable view of information about the connected device. Click the **Unit Information** icon (see [figure 81](#), [2](#)) on the **Global Navigation Bar** to open the page.

The following information is displayed:

- Part number
- Model name
- Model description
- Firmware version
- Temperature
- Default web version
- Device name
- DHCP status
- IP address
- Default gateway
- MAC address
- DNS server
- Subnet mask

Click the **License Information** button to view details about third-party packages and associated licensing.

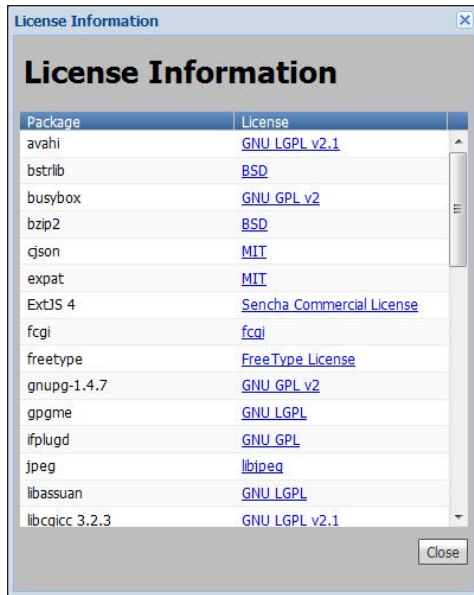

Figure 82. License Information Dialog Box

To view a copy of a listed package license, click the link in the **License** column for the relevant package (see [Licensed Third-Party Software Used in the Scalers](#) on page 6).

Device Name Page

The Device Name page allows users to assign or change the name or hostname of the connected device. Click the **Device Name** icon on the Hardware Global Navigation Bar (see [figure 81](#), [3](#), on the previous page) to open this page.

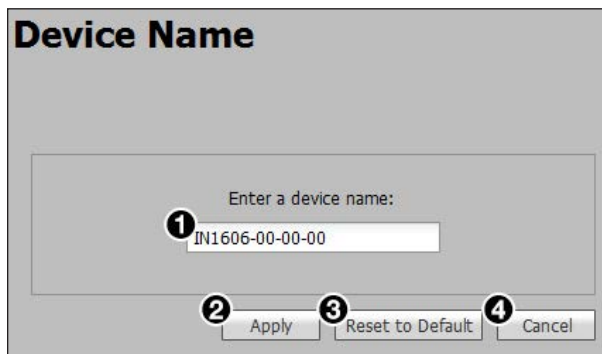

Figure 83. Device Name Page

NOTE: The device name is used as the hostname of the scaler.

To assign or change the hostname:

1. Enter a name for the device in the name field (see [figure 83](#), [1](#)). This can be up to 63 alphanumeric characters in length with no spaces between characters. If an invalid name is entered, a red symbol appears to the right of the name field.
2. Click the **Apply** button ([2](#)) to change the name or click the **Cancel** button ([4](#)) to keep the previous name.

To reset the name:

Click the **Reset to Default** button ([3](#)).

Communication Settings Page

The **Communication Settings** page contains options to adjust device settings for RS-232 and Ethernet connections. Click the **Communication Settings** icon on the Hardware Global Navigation Bar (see [figure 81](#), [4](#), on page 117) to open the page.

The screenshot shows the 'Communication Settings' page with two main sections: 'RS-232' and 'TCP/IP'. The 'RS-232' section includes fields for Baud Rate (9600), Parity Bit (None), Data Bit (8), and Stop Bit (1). The 'TCP/IP' section includes a Hostname field (IN1608-IPCP-MA-70-15-65-90), a 'Use DHCP' checkbox (checked), and four input fields for IP Address (192.168.254.254), Subnet Mask (255.255.0.0), Default Gateway (0.0.0.0), and DNS Server (0.0.0.0). A MAC Address field (00-05-A6-15-65-90) is also present. At the bottom, there are three buttons: 'Apply', 'Reset to Default', and 'Cancel'. Numbered callouts (1-8) are placed over the interface to indicate specific steps: 1 points to the 'Use DHCP' checkbox, 2 to the IP Address field, 3 to the Subnet Mask field, 4 to the Default Gateway field, 5 to the DNS Server field, 6 to the 'Apply' button, 7 to the 'Reset to Default' button, and 8 to the 'Cancel' button.

Figure 84. Communication Settings Page

Ethernet settings

To configure the Ethernet settings for use with DHCP:

1. Select the **Use DHCP** checkbox (see [figure 84](#), [1](#)).
2. Click the **Apply** button ([6](#)).

To configure the Ethernet settings with a static IP address:

1. Ensure the **Use DHCP** checkbox ([1](#)) is not selected.
2. In the **IP Address** field ([2](#)), enter an IP address.
3. In the **Subnet Mask** field ([3](#)), enter the subnet mask if required.
4. In the **Default Gateway** field ([4](#)), enter the default gateway if required.
5. In the **DNS Server** field ([5](#)), enter a DNS server name if required.
6. Click the **Apply** button ([6](#)).

To reset to default settings:

To reset the device to default connection values, click the **Reset to Default** button ([7](#)).

To cancel changes:

At any time, click the **Cancel** button ([8](#)) to keep the last saved settings.

Update Firmware Page

The Firmware Loader page provides a means of uploading firmware files to the connected scaler. Click the **Update Firmware** icon (see [figure 81](#), ⑤, on page 117) on the Global Navigation Bar to open this page.



Figure 85. Update Firmware Page

1. If necessary, download firmware updates from www.extron.com.
2. Click the **Browse** button (see [figure 85](#), ①). The Choose File to Upload window opens.
3. Navigate to the firmware file location and select the firmware file. Valid firmware files have an .eff extension.
4. Click the **Open** button. The window closes
5. Click the **Upload** button (②).

NOTE: The connection to the scaler may have to be reestablished.

Executive and Power Mode Page

The Executive and Power Mode page contains options for enabling or disabling the front panel lockout and power modes. Click the **Exec / Power Mode** icon (see [figure 81, 6](#), on page 117) on the Global Navigation Bar to open the page.

Executive / Power Mode

1 Executive Mode

- Unlock Front Panel
- Mode 1: Lock Front Panel
- Mode 2: Limit Front Panel To Input Selection and Volume

2 Power Mode

- Full Power
- Low Power - Standby State

3 Apply Cancel

Figure 86. Executive/Power Mode Page

Executive mode

Front panel lockout (executive) mode locks the front panel functions of the scaler.

1. Select one of the following radio buttons (see [figure 86, 1](#)) to set the executive mode (see [Front Panel Lockout \(Executive Modes\)](#) on page 40).
 - **Unlock the Front Panel** (default)
 - **Mode 1: Lock Front Panel** (complete lockout)
 - **Mode 2: Limit Front Panel To Input Selection and Volume**
2. Click the **Apply** button ([3](#)).

Power mode

The low power (standby) state disables all audio and video input processing and all audio and video outputs to save energy when the scaler is not in use.

1. Click the **Full Power** radio button or the **Low Power - Standby State** radio button ([2](#)) to select the desired power mode.

NOTE: It takes approximately 5-10 seconds to return the scaler to full power mode. Entering low power mode occurs immediately.

2. Click the **Apply** button ([3](#)).

Date and Time Page

The **Date and Time** page contains adjustable device date and time settings. Click the **Date and Time** icon (see [figure 81, 7](#), on page 117) on the Global Navigation Bar to open the page.

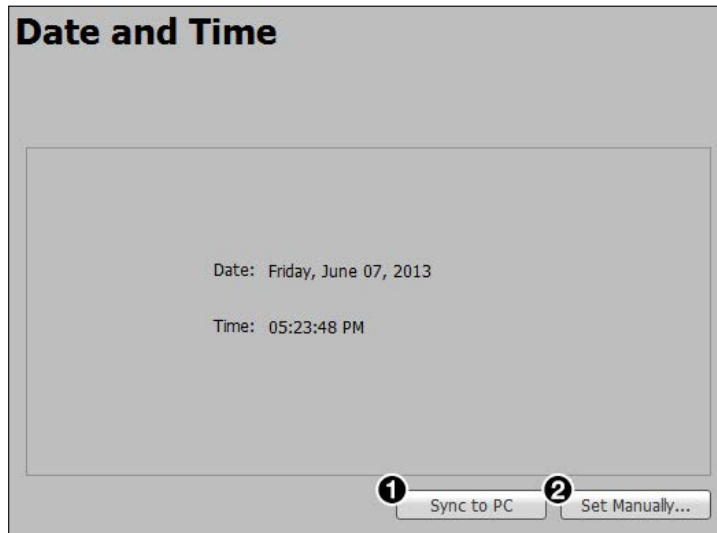

Figure 87. Date and Time Page

To automatically sync the date and time to a connected PC:

Click the **Sync to PC** button (see [figure 87, 1](#)).

To manually set the date and time:

1. Click the **Set Manually...** button ([2](#)). The **Date and Time Settings** dialog box opens.
2. Click the **Calendar** icon to open a calendar dialog box of selectable dates.
 - a. Click the **Date Picker** button to the right of the month and year to open a table of selectable months and years.

NOTE: Use the **Left** arrow or **Right** arrow button to view more years.
 - b. Select the month and year.
 - c. Click the **OK** button to accept the new settings or click the **Cancel** button to exit the dialog box.

NOTE: Alternatively, click the **Previous Month** or **Next Month** button on the far left and right of the month and year to cycle through dates.
 - d. Select the day.

NOTE: Click the **Today** button to select the current day on the host device.
3. Click outside the **Calendar** dialog box to save the selection.
4. For the **Time** fields, enter a valid value in the various time fields or click the **Up** or **Down** arrow button to specify hours, minutes, and seconds.
5. From the drop-down menu to the right of the **Seconds** field, select **AM** or **PM**.
6. Click the **Apply** button.

Password Page

The **Password** page allows you to set an administrator and user password on the device. Click the **Password** icon (see [figure 81](#), **3**, on page 117) on the **Global Navigation Bar** to open the page.

NOTE: The factory configured passwords for all accounts on this device have been set to the device serial number. Passwords are case sensitive. In the event of a reset to factory defaults, the passwords are set to no password.

Password

Login ID: admin

1 Administrator Password:

2 Confirm Password:

3 Show Characters

Login ID: user

4 User Password:

5 Confirm Password:

6 Show Characters

7

Figure 88. Password Page

Administrators and users can view all settings on the device. Administrators have the ability to make adjustments to any setting. Users can make changes only to input selection, volume, freeze, user preset recall, input preset recall, audio mute, video mute, Auto-Image, Auto-Image and Fill, and Auto-Image and Follow.

NOTE: If a password is set, a username is required to access the internal web pages or the device through the PCS program. When prompted, enter `admin` as the username for administrator passwords or `user` as the username for user passwords.

To create or change an administrator password:

1. In the **Administrator Password** field (see [figure 88](#), **1**), enter the desired administrator password.
2. In the **Confirm Password** field (**2**), reenter the administrator password.

NOTE: Select the **Show Characters** checkbox (**3**) to display the password characters.

3. Click the **Apply** button (**7**).

To create a user password:

NOTE: A user password cannot be set unless an administrator password exists.

1. In the **User Password** field (see **figure 88**, **4**, on the previous page) enter the desired user password.
2. In the **Confirm Password** field (**5**), reenter the user password.

NOTE: Select the **Show Characters** checkbox (**6**) to display the password characters.

3. Click the **Apply** button (**7**).

Reset Device Page

The **Reset Device** page allows the user to reset the device. Click on the **Reset Device** icon (see **figure 81**, **9** on page 117) on the **Global Navigation Bar** to open the page.

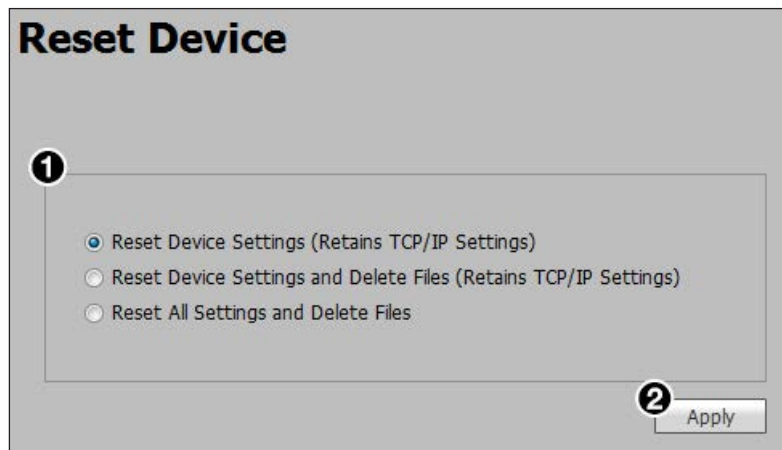

Figure 89. Reset Device Page

There are three reset options:

- **Reset Device Settings (Retains TCP/IP Settings)** — Resets the settings associated with input settings, the output image, EDID, and audio, and also includes presets and auto memories (excludes communication settings).

This is equivalent to the **[Esc] ZXXX←** SIS command.

NOTE: Communication settings include the IP address, subnet mask, gateway IP address, DHCP setting, and port mapping.

- **Reset Device Settings and Delete Files (Retains TCP/IP Settings)** — Resets all settings on the device to factory defaults (deletes user files), except the Ethernet settings.

This is equivalent to the **[Esc] ZY←** SIS command.

- **Reset All Settings and Delete Files** — Resets all settings on the device to factory defaults (deletes user files) including the communication settings.

This is equivalent to the **[Esc] ZQQQ←** SIS command.

NOTES:

- The default IP address is 192.168.254.254.
The default DHCP setting is Off.
- The factory configured passwords for all accounts on this device have been set to the device serial number. Passwords are case sensitive. In the event of a reset to factory defaults, the passwords are set to no password.

To reset the device:

1. Click the radio button of the desired reset option (see [figure 89](#), **1**, on the previous page).
2. Click the **Apply** button (**2**). A confirmation dialog box opens.
3. In the dialog box, click the **Reset** button to continue with the reset, or the **Cancel** button to abort the reset.

Reference Information

This section provides reference or supplemental information. Topics in this section include:

- [Mounting](#)
- [Downloading Updated Firmware](#)

Mounting

Tabletop Mounting

Attach the provided rubber feet to the bottom four corners of the enclosure.

Rack Mounting

UL guidelines for rack mounted devices

The following Underwriters Laboratories (UL) guidelines pertain to the safe installation of the scaler in a rack.

CAUTION:

- **Elevated operating ambient temperature** — If the equipment is installed in a closed or multi-unit rack assembly, the operating ambient temperature of the rack environment may be greater than room ambient temperature. Therefore, install the equipment in an environment compatible with the maximum ambient temperature (TMA = +122 °F, +50 °C) specified by Extron.
- **Reduced air flow** — Install the equipment in a rack so that the amount of air flow required for safe operation of the equipment is not compromised.
- **Mechanical loading** — When mounting the equipment in the rack, ensure that uneven mechanical loading does not cause a hazardous condition.
- **Circuit overloading** — When connecting the equipment to the supply circuit, consider the effect that circuit overloading might have on overcurrent protection and supply wiring. Consider equipment nameplate ratings when addressing this concern.
- **Reliable earthing (grounding)** — Maintain reliable grounding of rack mounted equipment. Pay particular attention to supply connections other than direct connections to the branch circuit (for example, use of power strips).

Consignes UL pour le montage en rack

Les consignes UL (« Underwriters Laboratories ») suivantes concernent l'installation en rack d'un boîtier IN1806 et IN1808 Series :

ATTENTION :

- **Température ambiante élevée** — En cas d'installation de l'équipement dans un rack fermé ou composé de plusieurs unités, la température du rack peut être supérieure à la température ambiante. Par conséquent, il est préférable d'installer l'équipement dans un environnement qui respecte la température ambiante maximale (T_{ma}) spécifiée par Extron.
- **Réduction du flux d'air** — Si l'équipement est installé dans un rack, veillez à ce que le flux d'air nécessaire pour un fonctionnement sécurisé de l'équipement soit respecté.
- **Charge mécanique** — Installez l'équipement en rack de manière à éviter toute situation dangereuse causée par le déséquilibre de la charge mécanique.
- **Surcharge électrique** — Lorsque vous connectez l'équipement au circuit d'alimentation, observez la connexion de l'équipement et étudiez les effets possibles d'une surcharge du circuit sur les protections contre les surintensités et les conducteurs d'alimentation. Consultez à cet égard les indications de la plaque d'identification de l'équipement.
- **Mise à la terre** — Assurez-vous que l'équipement est correctement mis à la terre. Accordez une attention particulière aux connexions électriques autres que les connexions directes au circuit de dérivation (ex. : les multiprises).

Mounting procedure

Mount the scalars into racks with the pre-installed rack ears (see [UL guidelines for rack mounted devices](#) on the previous page). To install the device, line up the screw holes on the rack ears on both side of the device with the screw holes in the rack so they device is level. Use the provided screws to attach the device to the rack.

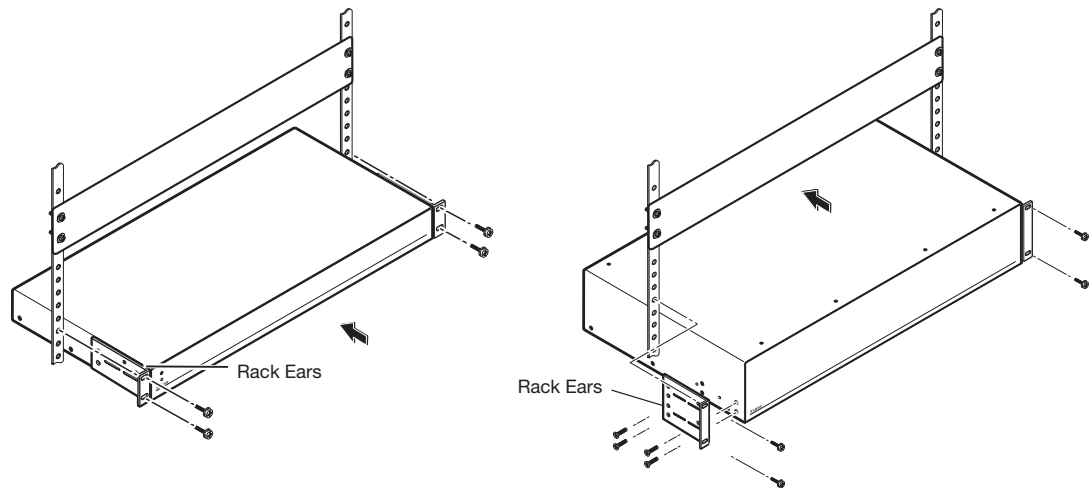

Figure 90. 1U Rack Mounting

2U Rack Mounting

Furniture Mounting

Go to www.extron.com, for a list of available furniture mounting kits. To install the scaler to furniture, follow the mounting kit instructions.

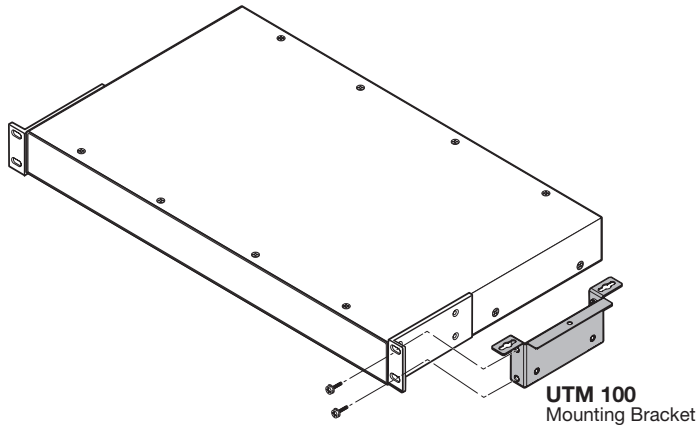

Figure 91. Under-Desk Mounting (UTM 100 Shown)

Downloading Updated Firmware

1. On the www.extron.com, click the **Download** tab (see figure 92, ①).
2. Move the pointer to the **Firmware** link (②) in the **Downloads** column and click it.

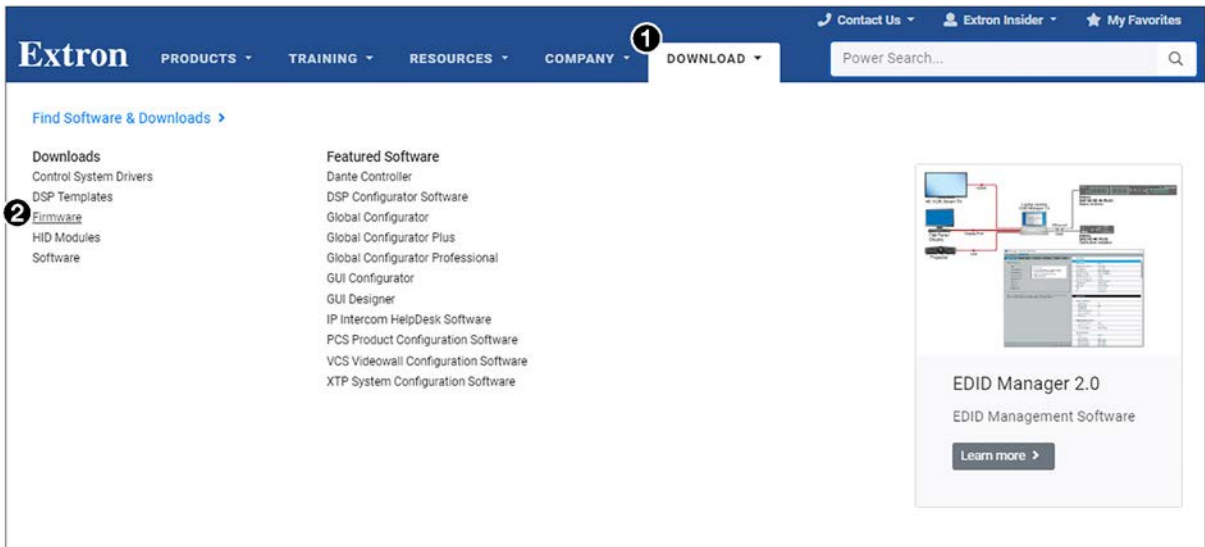

Figure 92. Downloading Firmware from the Extron Website

3. On the Download Center screen, click the **I** link (see figure 93, ①).

Download Center
Firmware (192 files)

ALL # A B C D E F G H **I** J K L M N O P Q R S T U V W X Y Z

Archives

Please consult Release Notes for important compatibility information and history.

Description	Part Number	Version	Date	Size	
IN1508 Firmware for the IN1508. Release Notes	19-1434-50	2.35	Feb. 6, 2014	2.1 MB	Download
IN1604 Firmware for the IN1604 Release Notes	49-268-01	1.16.0002	Nov. 8, 2017	5.9 MB	Download
IN1606/IN1608 Firmware Firmware upgrade for IN1606/IN1608 Release Notes	49-172-50	2.36.0003	May 21, 2018	36.9 MB	Download ②
IN1608 IPCP and IN1608 xi IPCP with Control Processor Updated Firmware for the integrated IP Link Pro Control Processor in IN1608 IPCP and IN1608 xi IPCP models. Release Notes	49-247-50-IPCP	3.00.0000-b022	Sep. 6, 2018	34.7 MB	Download

Figure 93. I Link on Firmware Download Center Page

4. Ensure the available firmware version is a later version than the current one on your device.

NOTE: The firmware release notes provide details about the changes between different firmware versions. The file can be downloaded from the same page as the firmware.

5. Click the **Download** link to the right of the desired device (②).
6. On the login page that appears next, fill in the required information to log in to www.extron.com (if you need an ID number, see your Extron representative).
7. Follow the instructions on the subsequent screens to complete the software program installation. By default, the configuration program files are stored on your computer at: C:\Program Files(x86)\Extron\Firmware\IN1606 and IN1608 Series
If there is not already an Extron folder in your Program Files x86 folder, the installation program creates it as well.

Extron Warranty

Extron warrants this product against defects in materials and workmanship for a period of three years from the date of purchase. In the event of malfunction during the warranty period attributable directly to faulty workmanship and/or materials, Extron will, at its option, repair or replace said products or components, to whatever extent it shall deem necessary to restore said product to proper operating condition, provided that it is returned within the warranty period, with proof of purchase and description of malfunction to:

**USA, Canada, South America,
and Central America:**

Extron
1230 South Lewis Street
Anaheim, CA 92805
U.S.A.

Asia:

Extron Asia Pte Ltd
135 Joo Seng Road, #04-01
PM Industrial Bldg.
Singapore 368363
Singapore

Japan:

Extron Japan
Kyodo Building, 16 Ichibancho
Chiyoda-ku, Tokyo 102-0082
Japan

Europe:

Extron Europe
Hanzeboulevard 10
3825 PH Amersfoort
The Netherlands

China:

Extron China
686 Ronghua Road
Songjiang District
Shanghai 201611
China

Africa and Middle East:

Extron Middle East
Dubai Airport Free Zone
F13, PO Box 293666
United Arab Emirates, Dubai

This Limited Warranty does not apply if the fault has been caused by misuse, improper handling care, electrical or mechanical abuse, abnormal operating conditions, or if modifications were made to the product that were not authorized by Extron.

NOTE: If a product is defective, please call Extron and ask for an Application Engineer to receive an RA (Return Authorization) number. This will begin the repair process.

USA: 714.491.1500 or 800.633.9876

Asia: 65.6383.4400

Europe: 31.33.453.4040 or 800.3987.6673

Japan: 81.3.3511.7655

Africa and Middle East: 971.4.299.1800

Units must be returned insured, with shipping charges prepaid. If not insured, you assume the risk of loss or damage during shipment. Returned units must include the serial number and a description of the problem, as well as the name of the person to contact in case there are any questions.

Extron Electronics makes no further warranties either expressed or implied with respect to the product and its quality, performance, merchantability, or fitness for any particular use. In no event will Extron Electronics be liable for direct, indirect, or consequential damages resulting from any defect in this product even if Extron Electronics has been advised of such damage.

Please note that laws vary from state to state and country to country, and that some provisions of this warranty may not apply to you.