

# WAP 100AC

Wireless Access Point



## Safety Instructions

### Safety Instructions • English

**WARNING:** This symbol, , when used on the product, is intended to alert the user of the presence of uninsulated dangerous voltage within the product's enclosure that may present a risk of electric shock.

**ATTENTION:** This symbol, , when used on the product, is intended to alert the user of important operating and maintenance (servicing) instructions in the literature provided with the equipment.

For information on safety guidelines, regulatory compliances, EMI/EMF compatibility, accessibility, and related topics, see the Extron Safety and Regulatory Compliance Guide, part number 68-290-01, on the Extron website, [www.extron.com](http://www.extron.com).

### تعليمات السلامة • العربية

**تحذير:** هذا الرمز، , عند استخدامه على المنتج، مخصص لتبنيته المستخدم فيما يتعلق بوجود جهد كهربائي غير معزول على الغلاف الخارجي للمنتج، وهو ما قد ينطوي على مخاطر حدوث صدمة كهربائية.

**انتبه:** هذا الرمز، , عند استخدامه على المنتج، مخصص لتبنيته المستخدم بتعليمات التشغيل والصيانة الهامة (الخدمة) في المواد التي يتم توفيرها مع المعدات.

للحصول على المزيد من المعلومات حول إرشادات السلامة، والتوافق التنظيمية، والتوافق الكهرومغناطيسي/المجال الكهرومغناطيسي، وإمكانية الوصول، والموضوعات ذات الصلة، يُرجى مراجعة دليل السلامة والتوافق التنظيمي [www.extron.com](http://www.extron.com) الخاص بإكسترون، الجزء رقم 68-290-01، على موقع إكسترون.

### Sicherheitsanweisungen • Deutsch

**WARUNG:** Dieses Symbol , auf dem Produkt soll den Benutzer darauf aufmerksam machen, dass im Inneren des Gehäuses dieses Produktes gefährliche Spannungen herrschen, die nicht isoliert sind und die einen elektrischen Schlag verursachen können.

**VORSICHT:** Dieses Symbol , auf dem Produkt soll dem Benutzer in der im Lieferumfang enthaltenen Dokumentation besonders wichtige Hinweise zur Bedienung und Wartung (Instandhaltung) geben.

Weitere Informationen über die Sicherheitsrichtlinien, Produkthandhabung, EMI/EMF-Kompatibilität, Zugänglichkeit und verwandte Themen finden Sie in den Extron-Richtlinien für Sicherheit und Handhabung (Artikelnummer 68-290-01) auf der Extron-Website, [www.extron.com](http://www.extron.com).

### Instrucciones de seguridad • Español

**ADVERTENCIA:** Este símbolo, , cuando se utiliza en el producto, avisa al usuario de la presencia de voltaje peligroso sin aislar dentro del producto, lo que puede representar un riesgo de descarga eléctrica.

**ATENCIÓN:** Este símbolo, , cuando se utiliza en el producto, avisa al usuario de la presencia de importantes instrucciones de uso y mantenimiento estas están incluidas en la documentación proporcionada con el equipo.

Para obtener información sobre directrices de seguridad, cumplimiento de normativas, compatibilidad electromagnética, accesibilidad y temas relacionados, consulte la Guía de cumplimiento de normativas y seguridad de Extron, referencia 68-290-01, en el sitio Web de Extron, [www.extron.com](http://www.extron.com).

### Instructions de sécurité • Français

**AVERTISSEMENT :** Ce pictogramme, , lorsqu'il est utilisé sur le produit, signale à l'utilisateur la présence à l'intérieur du boîtier du produit d'une tension électrique dangereuse susceptible de provoquer un choc électrique.

**ATTENTION :** Ce pictogramme, , lorsqu'il est utilisé sur le produit, signale à l'utilisateur des instructions d'utilisation ou de maintenance importantes qui se trouvent dans la documentation fournie avec l'équipement.

Pour en savoir plus sur les règles de sécurité, la conformité à la réglementation, la compatibilité EMI/EMF, l'accessibilité, et autres sujets connexes, lisez les informations de sécurité et de conformité Extron, réf. 68-290-01, sur le site Extron, [www.extron.com](http://www.extron.com).

### Istruzioni di sicurezza • Italiano

**AVVERTENZA:** Il simbolo, , se usato sul prodotto, serve ad avvertire l'utente della presenza di tensione non isolata pericolosa all'interno del contenitore del prodotto che può costituire un rischio di scosse elettriche.

**ATTENZIONE:** Il simbolo, , se usato sul prodotto, serve ad avvertire l'utente della presenza di importanti istruzioni di funzionamento e manutenzione nella documentazione fornita con l'apparecchio.

Per informazioni su parametri di sicurezza, conformità alle normative, compatibilità EMI/EMF, accessibilità e argomenti simili, fare riferimento alla Guida alla conformità normativa e di sicurezza di Extron, cod. articolo 68-290-01, sul sito web di Extron, [www.extron.com](http://www.extron.com).

### Instrukcje bezpieczeństwa • Polska

**OSTRZEŻENIE:** Ten symbol, , gdy używany na produkt, ma na celu poinformować użytkownika o obecności izolowanego i niebezpiecznego napięcia wewnątrz obudowy produktu, który może stanowić zagrożenie porażenia prądem elektrycznym.

**UWAGI:** Ten symbol, , gdy używany na produkt, jest przeznaczony do ostrzeżenia użytkownika ważne operacyjne oraz instrukcje konserwacji (obsługi) w literaturze, wyposażone w sprzęt.

Informacji na temat wytycznych w sprawie bezpieczeństwa, regulacji wzajemnej zgodności, zgodność EMI/EMF, dostępności i Tematy pokrewne, zobacz Extron bezpieczeństwa i regulacyjnego zgodności przewodnik, część numer 68-290-01, na stronie internetowej Extron, [www.extron.com](http://www.extron.com).

### Инструкция по технике безопасности • Русский

**ПРЕДУПРЕЖДЕНИЕ:** Данный символ, , если указан на продукте, предупреждает пользователя о наличии неизолированного опасного напряжения внутри корпуса продукта, которое может привести к поражению электрическим током.

**ВНИМАНИЕ:** Данный символ, , если указан на продукте, предупреждает пользователя о наличии важных инструкций по эксплуатации и обслуживанию в руководстве, прилагаемом к данному оборудованию.

Для получения информации о правилах техники безопасности, соблюдении нормативных требований, электромагнитной совместимости (ЭМП/ЭДС), возможности доступа и других вопросах см. руководство по безопасности и соблюдению нормативных требований Extron на сайте Extron: [www.extron.com](http://www.extron.com), номер по каталогу - 68-290-01.

## 安全说明 • 简体中文

**警告:** ⚠️ 产品上的这个标志意在警告用户, 该产品机壳内有暴露的危险电压, 有触电危险。

**注意:** ⚠️ 产品上的这个标志意在提示用户, 设备随附的用户手册中有重要的操作和维护(维修)说明。

关于我们产品的安全指南、遵循的规范、EMI/EMF 的兼容性、无障碍使用的特性等相关内容, 敬请访问 Extron 网站, [www.extron.com](http://www.extron.com), 参见 Extron 安全规范指南, 产品编号 68-290-01。

## 安全記事 • 繁體中文

**警告:** ⚠️ 若產品上使用此符號, 是為了提醒使用者, 產品機殼內存在未隔離的危險電壓, 可能會導致觸電之風險。

**注意:** ⚠️ 若產品上使用此符號, 是為了提醒使用者, 設備隨附的用戶手冊中有重要的操作和維護(維修)說明。

有關安全性指導方針、法規遵守、EMI/EMF 相容性、存取範圍和相關主題的詳細資訊, 請瀏覽 Extron 網站: [www.extron.com](http://www.extron.com), 然後參閱《Extron 安全性與法規遵守手冊》, 準則編號 68-290-01。

## 安全上のご注意 • 日本語

**警告:** この記号 ⚠️ が製品上に表示されている場合は、筐体内に絶縁されていない高電圧が流れ、感電の危険があることを示しています。

**注意:** この記号 ⚠️ が製品上に表示されている場合は、本機の取扱説明書に記載されている重要な操作と保守(整備)の指示についてユーザーの注意を喚起するものです。

安全上のご注意、法規遵守、EMI/EMF適合性、その他の関連項目については、エクストロンのウェブサイト [www.extron.com](http://www.extron.com) より「Extron Safety and Regulatory Compliance Guide」(P/N 68-290-01) をご覧ください。

## 안전 지침 • 한국어

**경고:** 이 기호 ⚠️ 가 제품에 사용될 경우, 제품의 인클로저 내에 있는 접지되지 않은 위험한 전류로 인해 사용자가 감전될 위험이 있음을 경고합니다.

**주의:** 이 기호 ⚠️ 가 제품에 사용될 경우, 장비와 함께 제공된 책자에 나와 있는 주요 운영 및 유지보수(정비) 지침을 경고합니다.

안전 가이드라인, 규제 준수, EMI/EMF 호환성, 접근성, 그리고 관련 항목에 대한 자세한 내용은 Extron 웹 사이트([www.extron.com](http://www.extron.com))의 Extron 안전 및 규제 준수 안내서, 68-290-01 조항을 참조하십시오.

## Copyright

© 2017 - 2021 Extron. All rights reserved. [www.extron.com](http://www.extron.com)

All trademarks mentioned are the property of their respective owners.

Trademarks

All trademarks mentioned in this guide are the properties of their respective owners.

The following registered trademarks (®), registered service marks (SM), and trademarks (TM) are the property of RGB Systems, Inc. or Extron (see the current list of trademarks on the [Terms of Use](#) page at [www.extron.com](http://www.extron.com)):

### Registered Trademarks (®)

Cable Cubby, ControlScript, CrossPoint, DTP, eBUS, EDID Manager, EDID Minder, Extron, eLink, Flat Field, FlexOS, Glitch Free, Global Configurator, Global Scripter, GlobalViewer, Hideaway, HyperLane, IP Intercom, IP Link, Key Minder, LinkLicense, LockIt, MediaLink, MediaPort, NAV, NetPA, PlenumVault, PoleVault, PowerCage, PURE3, Quantum, ShareLink, Show Me, SoundField, SpeedMount, SpeedSwitch, StudioStation, System *INTEGRATOR*, TeamWork, TouchLink, V-Lock, VideoLounge, VN-Matrix, Voicelift, WallVault, WindowWall, XPA, XTP, XTP Systems, and ZipClip.

**Registered Service Mark (SM):** S3 Service Support Solutions

### Trademarks (TM)

AAP, AFL (Accu-RATE Frame Lock), ADSP (Advanced Digital Sync Processing), AVEdge, CableCover, CDRS (Class D Ripple Suppression), Codec Connect, DDSP (Digital Display Sync Processing), DMI (Dynamic Motion Interpolation), Driver Configurator, DSP Configurator, DSVP (Digital Sync Validation Processing), EQIP, Everlast, FastBite, Flex55, FOX, FOXBOX, IP Intercom HelpDesk, MAAP, MicroDigital, Opti-Torque, PendantConnect, ProDSP, QS-FPC (QuickSwitch Front Panel Controller), Room Agent, Scope-Trigger, SIS, Simple Instruction Set, Skew-Free, SpeedNav, Triple-Action Switching, True4K, True8K, Vector™ 4K, WebShare, XTRA, and ZipCaddy

# FCC Class B Notice

## Federal Communication Commission Interference Statement

This equipment has been tested and found to comply with the limits for a Class B digital device, pursuant to Part 15 of the FCC Rules. These limits are designed to provide reasonable protection against harmful interference in a residential installation. This equipment generates, uses and can radiate radio frequency energy and, if not installed and used in accordance with the instructions, may cause harmful interference to radio communications. However, there is no guarantee that interference will not occur in a particular installation. If this equipment does cause harmful interference to radio or television reception, which can be determined by turning the equipment off and on, the user is encouraged to try to correct the interference by one of the following measures:

- Reorient or relocate the receiving antenna.
- Increase the separation between the equipment and receiver.
- Connect the equipment into an outlet on a circuit different from that to which the receiver is connected.
- Consult the dealer or an experienced radio/TV technician for help.

**FCC CAUTION:** Any changes or modifications not expressly approved by the party responsible for compliance could void the user's authority to operate this equipment.

This device complies with Part 15 of the FCC Rules. Operation is subject to the following two conditions:

1. This device may not cause harmful interference, and
2. This device must accept any interference received, including interference that may cause undesired operation.

This transmitter must not be co-located or operating in conjunction with any other antenna or transmitter.

Operations in the 5.15-5.25GHz band are restricted to indoor usage only.

### **IMPORTANT NOTE:**

#### **FCC Radiation Exposure Statement:**

This equipment complies with FCC radiation exposure limits set forth for an uncontrolled environment. This equipment should be installed and operated with minimum distance 25cm between the radiator & your body.

## Industry Canada Statement:

This device complies with RSS-247 of the Industry Canada Rules. Operation is subject to the following two conditions: (1) This device may not cause harmful interference, and (2) this device must accept any interference received, including interference that may cause undesired operation.

Ce dispositif est conforme à la norme CNR-247 d'Industrie Canada applicable aux appareils radio exempts de licence. Son fonctionnement est sujet aux deux conditions suivantes: (1) le dispositif ne doit pas produire de brouillage préjudiciable, et (2) ce dispositif doit accepter tout brouillage reçu, y compris un brouillage susceptible de provoquer un fonctionnement indésirable.

**CAUTION:** The device for operation in the band 5150-5250 MHz is only for indoor use to reduce the potential for harmful interference to co-channel mobile satellite systems;

**ATTENTION :** Les dispositifs fonctionnant dans la bande 5150-5250 MHz sont réservés uniquement pour une utilisation à l'intérieur afin de réduire les risques de brouillage préjudiciable aux systèmes de satellites mobiles utilisant les mêmes canaux;

**CAUTION:** High-power radars are allocated as primary users (i.e. priority users) of the bands 5250-5350 MHz and 5650-5850 MHz and that these radars could cause interference and/or damage to LE-LAN devices.

**ATTENTION :** De plus, les utilisateurs devraient aussi être avisés que les utilisateurs de radars de haute puissance sont désignés utilisateurs principaux (c.-à-d., qu'ils ont la priorité) pour les bandes 5250-5350 MHz et 5650-5850 MHz et que ces radars pourraient causer du brouillage et/ou des dommages aux dispositifs LAN-EL.

## FOR MOBILE DEVICE USAGE

### Radiation Exposure Statement:

This equipment complies with IC radiation exposure limits set forth for an uncontrolled environment. This equipment should be installed and operated with minimum distance 22 cm between the radiator and your body.

### Déclaration d'exposition aux radiations:

Cet équipement est conforme aux limites d'exposition aux rayonnements IC établies pour un environnement non contrôlé. Cet équipement doit être installé et utilisé avec un minimum de 22 cm de distance entre la source de rayonnement et votre corps.

**NOTE:** For more information on safety guidelines, regulatory compliances, EMI/EMF compatibility, accessibility, and related topics, see the [Extron Safety and Regulatory Compliance Guide](#) on the Extron website.

## Battery Notice

This product contains a battery. **Do not open the unit to replace the battery.** If the battery needs replacing, return the entire unit to Extron (for the correct address, see the [Extron Warranty](#) section on the last page of this guide).

**CAUTION:** Risk of Explosion if Battery is replaced by an Incorrect Type. Dispose of Used Batteries According to the Instructions.

**ATTENTION :** Risque d'explosion. Ne pas remplacer la pile par le mauvais type de pile. Débarrassez-vous des piles utilisées selon le mode d'emploi.

## Conventions Used in this Guide

### Notifications

In this user guide, the following are used:

**CAUTION:** Risk of minor personal injury.

**ATTENTION :** Risque de blessure mineure.

**ATTENTION:**

- Risk of property damage.
- Risque de dommages matériels.

**NOTE:** A note draws attention to important information.

### Software Commands

Directory paths that do not have variables are written in the font shown here:

`C:\Program Files\Extron`

Variables are written in slanted form as shown here:

`ping xxx.xxx.xxx.xxx -t`

`SOH R Data STX Command ETB ETX`

Selectable items, such as menu names, menu options, buttons, tabs, and field names are written in the font shown here:

From the **File** menu, select **New**.

Click the **OK** button.

### Specifications Availability

Product specifications are available on the Extron website, [www.extron.com](http://www.extron.com).

### Extron Glossary of Terms

A glossary of terms is available at [www.extron.com/technology/glossary.aspx](http://www.extron.com/technology/glossary.aspx).

# Contents

---

## **Introduction..... 1**

About the WAP 100AC .....	1
Features.....	1
Application Diagram .....	2

---

## **Installation Overview ..... 3**

---

## **Panel Features ..... 4**

WAP 100AC Top Panel Features .....	4
Connecting Power .....	5
Power over Ethernet .....	5
12 VDC Power Supply .....	5
Power Supply and Power Injector Safety Information.....	6
WAP 100AC Bottom Panel Features .....	7

---

## **Internal Web Pages..... 8**

Accessing the Internal Web Pages .....	8
Web Page Features.....	9
Overview .....	10
Device Status.....	10
Connections .....	11
Network .....	12
Basic .....	12
Wireless .....	14
WPS .....	19
Management.....	20
Advanced .....	20
Time Zone.....	21
WiFi Scheduler.....	22
Tools .....	23
System Manager .....	27
Account .....	27
Firmware.....	28
Log .....	30

---

## **Building a Wireless Network..... 31**

Access Point Mode.....	31
WDS AP Mode.....	32
WDS Bridge Mode .....	33

---

## **Security Settings ..... 34**

WEP .....	35
WPA-PSK .....	36
WPA2-PSK .....	37
WPA-PSK Mixed .....	38
WPA-Enterprise.....	39
WPA2-Enterprise.....	40
WPA Mixed Enterprise.....	41
Fast Roaming.....	42
Wireless MAC Filter .....	42
Wireless Traffic Shaping .....	43

---

## **Mounting..... 44**

Before You Start.....	44
Mounting the WAP 100AC .....	44
Mounting to a Solid Ceiling or Wall .....	45
Mounting to a Dropped Ceiling.....	46
Kensington Security Lock .....	47



# Introduction

This guide describes the function, installation, and operation of the Extron WAP 100AC Wireless Access Point.

Unless otherwise stated, the terms “Wireless Access Point” or “WAP” refer to the WAP 100AC.

This section provides an overview of these products:

- [About the WAP 100AC](#)
- [Features](#)
- [Application Diagram](#)

## About the WAP 100AC

The WAP 100AC is a high-powered, long-range, dual-band concurrent wireless access point. It is compliant with IEEE 802.11ac/a/b/g/n standards up to 300 Mbps at 2.4 GHz and up to 867 Mbps at 5 GHz.

It is designed to operate in numerous environments, including multiple-floor offices and other larger enterprise settings, where the high power and long range make it a cost-effective alternative to ordinary access points.

## Features

- **Supports both IEEE 802.11a/n/ac on 5 GHz and IEEE 802.11b/g/n on 2.4 GHz standards** — Allows for speeds up to 866 Mbps on the 5 GHz band and up to 300 Mbps on the 2.4 GHz band, while providing support for the latest devices.
- **Four Internal 5 dBi Omni-Directional Antennas** — Help minimize interference for enhanced reliability.
- **LED indicators for WPS, WLAN 5G, WLAN 2.4G, Ethernet port, and Power** — Provide at-a-glance status of the device.
- **Enhanced network security** — Supports industry wireless encryption standards such as Wi-Fi Protected Access - WPA/WPA2 Enterprise/PSK, 802.1X with RADIUS and MAC Address Filtering, allowing for a more secure network.
- **Fast Roaming with Enhanced Security** — Helps maintain a secure connection to the network when moving from the range of one access point to another with a stronger signal.
- **Band Steering** — Automatically directs dual band clients to the less congested 5 GHz frequency helping to maximize efficiency.
- **8 SSID per band** — Allows for different types of wireless network access for multiple device types or multiple users.
- **Gigabit Ethernet** — Convenient way to steer packets to specific ports or interfaces.
- **Versatile, Multi-Mode Support: AP, WDS Bridge and WDS AP** — Provides flexible deployment options depending on your need.
- **VLAN tagging**
- **Supports Power over Ethernet Plus (PoE+)** — Reduces the cable drops to the wireless access point.
- **Supports the Extron Control App for iOS and Android.**
- **Low-Profile Ceiling-Mount Option with Included Mounting T-Rail.**
- **Kensington lock support.**

# Application Diagram

Figure 1 shows a typical application for the WAP 100AC.

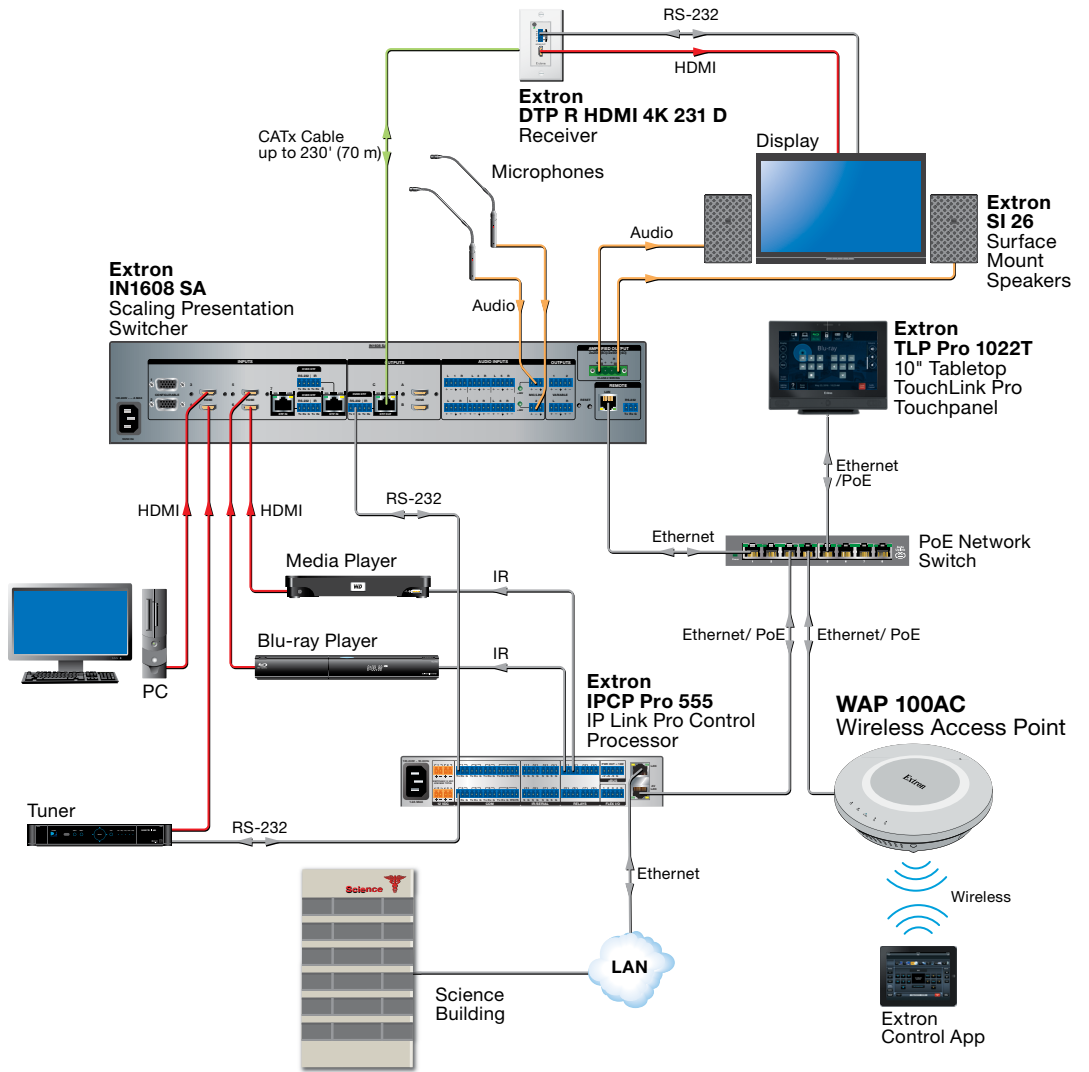

**Figure 1. WAP 100AC Application Diagram**

# Installation Overview

This section contains an overview of the installation process. Follow the links for a more detailed explanation of each step.

1. Before starting, determine where to mount the WAP 100AC for optimal performance, consider factors that can affect signal strength (see [Before You Start](#) on page 44).
2. Obtain the following network information from your network administrator:
  - Dynamic Host Configuration Protocol (DHCP) status (on or off). If DHCP is off, you also require:
    - IP address (default: 192.168.1.1)
    - Subnet mask (default: 255.255.255.0)
    - Gateway
  - User name — By default this is `admin`.
  - Password — The factory configured passwords for all accounts on this device have been set to the device serial number. Passwords are case sensitive.

**NOTE:** If the device is reset to default settings, the passwords are reset to the default password, which is `extron` (for either `admin` or `user`).

- MAC address — Make a note of the WAP 100AC MAC address, which can be found on the WAP 100AC top panel label.
3. Mount and cable the units:
    - Prepare the mounting site (see [Mounting](#) on page 44).

**NOTE:** Prepare the mounting site but do not install the WAP 100AC until power and network connections have been made.

**ATTENTION:**

- Do not power on the WAP 100AC until you have read the [Attention](#) on page 6.
- Ne branchez pas le WAP 100AC avant d'avoir lu les [mises en garde](#) page 6.

- Connect the network cable to the WAP 100AC. If you are using PoE, see [LAN/PoE input](#) on page 4.
  - Extron recommends using PoE. If you are not using Power over Ethernet, see [12 VDC power input](#) on page 4.
  - Mount the WAP 100AC (see [Mounting](#)).
4. Configure the WAP 100AC for Network Communication:
    - Connect the PC that you are using for setup to the same Ethernet subnetwork as the WAP 100AC.
    - Use the WAP 100AC [Internal Web Pages](#) to configure the unit (see page 8).

# Panel Features

This section describes:

- [WAP 100AC Top Panel Features](#)
- [Connecting Power](#)
- [WAP 100AC Bottom Panel Features](#)

## WAP 100AC Top Panel Features

Figure 2 shows the top panel features of the WAP 100AC.

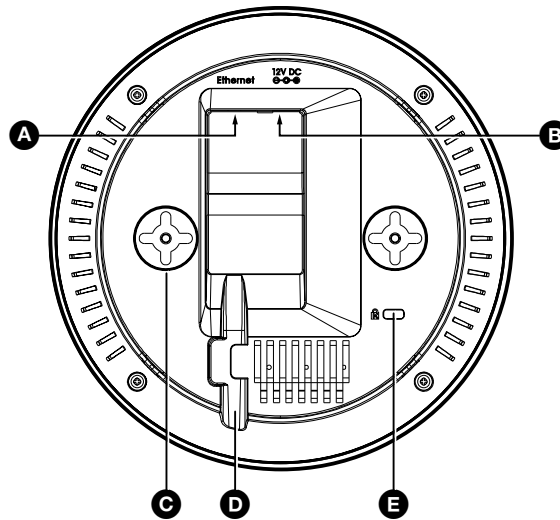

**Figure 2.** WAP 100AC Top Panel

**NOTE:** The WAP 100AC can use a 12 VDC, minimum 1.0 A power supply or a 48 VDC, minimum 0.35 A PoE+ (802.3at compliant) power injector. Extron recommends using a PoE+ (802.3at compliant) power injector.

- A LAN/PoE input** — If a PoE power injector is used, connect this input to a PoE power injector (see [Power over Ethernet](#) on page 5).  
If a 12 VDC power supply (see [12 VDC Power Supply](#) on page 5) is used, connect this input directly to switch or router.
- B 12 VDC power input** — If a 12 VDC power supply (see [12 VDC Power Supply](#)) is used, connect this input to a 12 VDC, minimum 1.0 A power supply with a DC plug.  
If a PoE power injector is used, do not connect a power supply to this input.
- C Mounting holes (2)** — Used to mount the unit to a wall or ceiling (see [Mounting](#) on page 44).
- D Cable guide** — Ensures cables for power and network connections do not get damaged.
- E Kensington security lock** — For added security, attach a Kensington Security Lock (not provided) to the metal-reinforced slot on the top of the unit.  
Follow the instructions that are provided by the manufacturer to install the lock.

## Connecting Power

### ATTENTION:

- Do not power on the WAP 100AC until you have read the **Attention** on page 6.
- Ne branchez pas le WAP 100AC avant d'avoir lu les **mises en garde** page 6.

### NOTES:

- The WAP 100AC ships without a power supply. Either a 12 VDC, minimum 1.0 A power supply or a 48 VDC, minimum 0.35 A PoE+ (802.3at compliant) power injector must be purchased separately.
- Do not use both the 12 VDC power supply and power injector at the same time.

## Power over Ethernet

To use a PoE power injector, follow these instructions. Figure 3 shows the PI 140. Your power injector may look different.

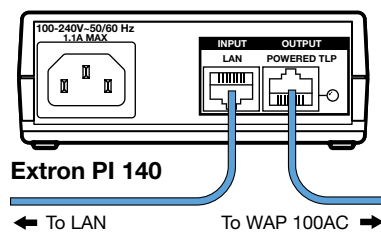

**Figure 3. Connecting a PoE Power Injector to the WAP 100AC**

1. Use an Ethernet cable to connect the PoE injector to a switch or router. This cable carries network information from the switch or router to the power injector.
2. Use a second Ethernet cable to connect the PoE injector to the Ethernet input of the WAP 100AC (see [figure 2](#), **A**, on page 4). This cable carries the network information and power from the power supply to the WAP 100AC.
3. Use an IEC power cord to connect the power injector to a convenient 100 VAC to 240 VAC, 50-60 Hz power source.

Alternatively, use an Ethernet cable to connect the Ethernet port of the WAP 100AC to a PoE+ switch.

Limit the use to no more than two pass-through points, which may include patch points, punch down connectors, couplers and power injectors. If these pass-through points are required, use shielded couplers and punch-down connectors

**NOTES:** When using shielded twisted pair cable in bundles or conduits, consider the following:

- Do not exceed 40% fill capacity in conduits.
- Do not comb the cable for the first 20 meters, where cables are straightened, aligned, and secured in tight bundles.
- Loosely place cables and limit the used of tie wraps or hook-and-loop fasteners.
- Keep twisted pair cables separate from AC power cables.

## 12 VDC Power Supply

If you are using a 12 VDC power supply, the Ethernet input (see [figure 2](#), **A**, on page 4) must be connected directly to a switch or router.

Connect a 12 VDC, minimum 1.0 A power supply with a DC plug to the 12 VDC input (**B**).

## Power Supply and Power Injector Safety Information

### ATTENTION:

- If not provided with a power supply, this product is intended to be supplied by a UL Listed power source marked “Class 2” or “LPS” and rated output 12 VDC, minimum 1.0 A or 48 VDC (PoE), minimum 0.35 A.
  - Si le produit n'est pas fourni avec une source d'alimentation, il doit être alimenté par une source d'alimentation certifiée UL de classe 2 ou LPS, avec une tension nominale 12 Vcc, 1,0 A minimum ou 48 Vcc (PoE), 0,35 A minimum.
- 
- Always use a power supply provided by or specified by Extron. Use of an unauthorized power supply voids all regulatory compliance certification and may cause damage to the supply and the end product.
  - Utilisez toujours une source d'alimentation fournie ou recommandée par Extron. L'utilisation d'une source d'alimentation non autorisée annule toute conformité réglementaire et peut endommager la source d'alimentation ainsi que le produit final.
- 
- The installation must always be in accordance with the applicable provisions of National Electrical Code ANSI/NFPA 70, article 725 and the Canadian Electrical Code part 1, section 16.
  - Cette installation doit toujours être en accord avec les mesures qui s'applique au National Electrical Code ANSI/NFPA 70, article 725, et au Canadian Electrical Code, partie 1, section 16.
- 
- Unless otherwise stated, the AC/DC adapters are not suitable for use in air handling spaces or in wall cavities. The power supply is to be located within the same vicinity as the Extron AV processing equipment in an ordinary location, Pollution Degree 2, secured to the equipment rack within the dedicated closet, podium, or desk.
  - Sauf mention contraire, les adaptateurs AC/DC ne sont pas appropriés pour une utilisation dans les espaces d'aération ou dans les cavités murales. La source d'alimentation doit être située à proximité de l'équipement de traitement audiovisuel dans un endroit ordinaire, avec un degré 2 de pollution, fixé à un équipement de rack à l'intérieur d'un placard, d'une estrade, ou d'un bureau.
- 
- Power over Ethernet (PoE) is intended for indoor use only. It is to be connected only to networks or circuits that are not routed to the outside plant or building.
  - L'alimentation via Ethernet (PoE) est destinée à une utilisation en intérieur uniquement. Elle doit être connectée seulement à des réseaux ou des circuits qui ne sont pas routés au réseau ou au bâtiment extérieur.
- 
- The power supply shall not be permanently fixed to the building structure or similar structure.
  - La source d'alimentation ne devra pas être fixée de façon permanente à une structure de bâtiment ou à une structure similaire.
- 
- This product is intended for connection to a Power over Ethernet circuit for intra-building use only and is considered to be part of a Network Environment 0 per IEC TR62101.
  - Cet produit est conçu pour une connexion à un circuit PoE pour une utilisation intérieure seulement et est considéré comme faisant partie d'un environnement réseau 0 par IEC TR62101.

## WAP 100AC Bottom Panel Features

These features provide diagnostic tools that can be used for troubleshooting. The LEDs can be activated or inactivated within the WAP 100AC web pages.

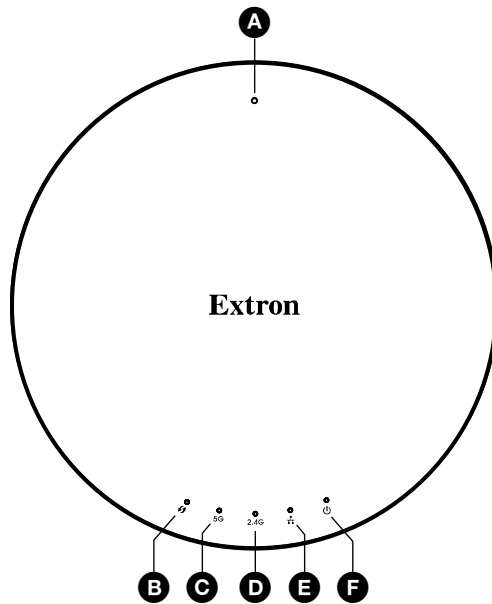

**Figure 4. WAP 100AC Bottom Panel**

- A Reset button** — Resets all user settings and reverts back to the factory default state. To carry out this reset, press the reset button for more than 10 seconds.
- B WPS LED** — Indicates Wi-Fi Protected Setup is enabled.
- C WLAN 5G LED** — Indicates that the 5 GHz frequency is in use (IEEE standard 802.11a, b, g, n,ac).
- D WLAN 2.4G LED** — Indicates that the 2.4 GHz frequency is in use (IEEE standard 802.11a, b, g, n,ac).
- E Ethernet Port LED** — Indicates that the unit is connected to a network.
- F Power LED** — Indicates that the unit is receiving power.

# Internal Web Pages

The WAP 100AC hosts internal web pages that are used to configure the unit. This section describes how to access the internal web pages and a description of each page.

- [Accessing the Internal Web Pages](#)
- [Web Page Features](#)
- [Overview](#)
- [Network](#)
- [Management](#)
- [System Manager](#)

## Accessing the Internal Web Pages

To access the internal web pages:

1. Ensure the WAP 100AC is powered on and connected to a network.
2. Open a web browser on a PC connected to the same subnetwork as the WAP 100AC.
3. Enter the IP address of the WAP 100AC in the address bar. By default this is 192.168.1.1.
4. The Login dialog box opens:

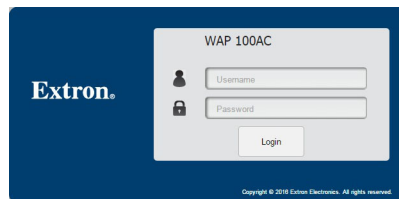

**Figure 5.** Login Dialog Box

5. Click **Login**.  
The Device Status page opens.

### NOTES:

- The factory configured passwords for all accounts on this device have been set to the device serial number. Passwords are case sensitive.
- If the device is reset to default settings, the passwords are reset to the default password, which is **extron** (for either **admin** or **user**).

# Web Page Features

The following features are found on all the WAP 100AC web pages.

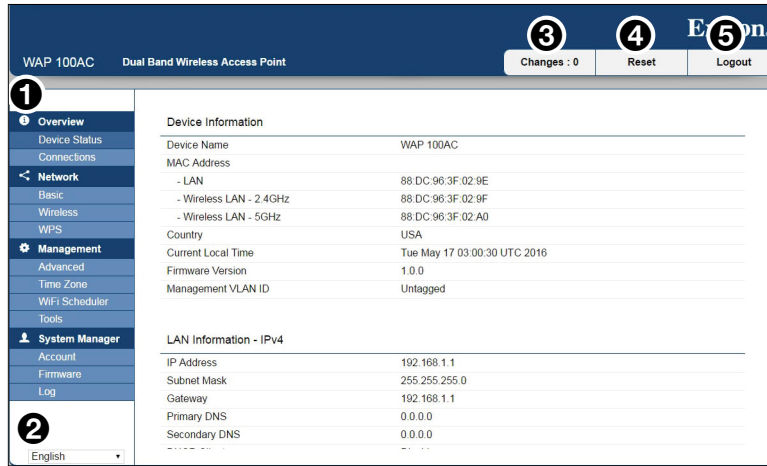

**Figure 6. Web Page Features**

- 1 **Menu** — Allows you to navigate to the appropriate web page.
- 2 **Language** — Allows you to select the language in which the web pages are presented.
- 3 **Changes** — After making changes to any of the web pages, click **Save** on that page to save those changes. However, to apply those changes, click the **Changes** button at the top of the page.

This opens the **Changes** window, which lists all the changes you have made. You can click **Apply** to apply all the changes, or **Revert** to remove the changes and revert to the previous state. The **Changes** button also provides a cumulative total of the changes made.

**NOTE:** On the **Changes** page you can apply all the changes or none of the changes applied. You cannot apply some changes but not others. You must go back to the individual web pages to undo those changes that you do not want to apply.

When you press **Apply** or **Revert**, the list of changes is removed from the **Changes** page and the cumulative total shown on the button returns to 0.

- 4 **Reset** — Allows the user to choose between:
  - Reboot the WAP 100AC
  - Reset to factory default values
  - Reset to user-defined default values

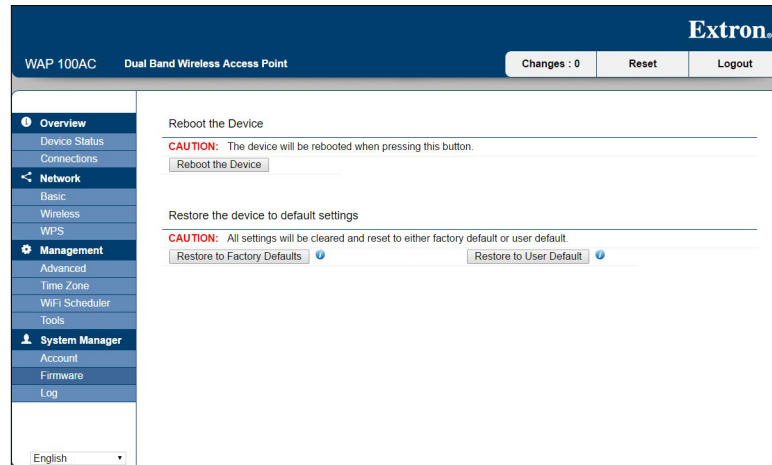

**Figure 7. Reset Page**

- 5 **Logout** — Shuts down the current session and exits from the web pages.

# Overview

## Device Status

The **Device Status** page is read-only and shows general information about the WAP 100AC. To view this information, click **Device Status** (1) in the **Overview** section of the left side bar.

The information on this page is organized under **Device Information** (see figure 8, 2) and **LAN Information** (see figure 9, 1).

### Device information

The screenshot shows the Extron WAP 100AC web interface. The top navigation bar includes the Extron logo, the device name 'WAP 100AC Dual Band Wireless Access Point', and buttons for 'Changes : 0', 'Reset', and 'Logout'. The left sidebar contains a menu with categories: Overview (1), Device Status, Connections, Network, Basic, Wireless, WPS, Management (with a gear icon), Advanced, Time Zone, WiFi Scheduler, Tools, System Manager (with a person icon), Account, Firmware, and Log. The main content area is titled 'Device Information' (2) and contains two sections: 'Device Information' and 'LAN Information - IPv4'. The 'Device Information' section lists: Device Name (WAP 100AC), MAC Address, LAN (88:DC:96:3F:02:9E), Wireless LAN - 2.4GHz (88:DC:96:3F:02:9F), Wireless LAN - 5GHz (88:DC:96:3F:02:A0), Country (USA), Current Local Time (Tue May 17 03:00:30 UTC 2016), Firmware Version (1.0.0), and Management VLAN ID (Untagged). The 'LAN Information - IPv4' section lists: IP Address (192.168.1.1), Subnet Mask (255.255.255.0), Gateway (192.168.1.1), Primary DNS (0.0.0.0), and Secondary DNS (0.0.0.0). A language dropdown menu at the bottom left is set to 'English'.

Device Information	
Device Name	WAP 100AC
MAC Address	
- LAN	88:DC:96:3F:02:9E
- Wireless LAN - 2.4GHz	88:DC:96:3F:02:9F
- Wireless LAN - 5GHz	88:DC:96:3F:02:A0
Country	USA
Current Local Time	Tue May 17 03:00:30 UTC 2016
Firmware Version	1.0.0
Management VLAN ID	Untagged

LAN Information - IPv4	
IP Address	192.168.1.1
Subnet Mask	255.255.255.0
Gateway	192.168.1.1
Primary DNS	0.0.0.0
Secondary DNS	0.0.0.0

**Figure 8. Device Status Page showing Device Information**

- **Device Name**
- **MAC Address** — The WAP 100AC has separate MAC addresses for connecting to a LAN, WLAN (2.4 GHz), and WLAN (5 GHz).
- **Country** — To configure the country or region, see [Wireless settings](#) on page 14.
- **Current Local Time** — To configure date and time, see [Time Zone](#) on page 21.
- **Firmware Version** — To update firmware, see [Firmware](#) on page 28.
- **Management VLAN ID** — If your network includes VLANs, you can assign a Management VLAN ID (see [Management VLAN settings](#) on page 18).

## LAN information

WAP 100AC Dual Band Wireless Access Point Changes: 0 Reset Logout

Overview  
Device Status  
Connections  
Network  
Basic  
Wireless  
WPS  
Management  
Advanced  
Time Zone  
WiFi Scheduler  
Tools  
System Manager  
Account  
Firmware  
Log

English

### LAN Information - IPv4

IP Address	192.168.1.1
Subnet Mask	255.255.255.0
Gateway	192.168.1.1
Primary DNS	0.0.0.0
Secondary DNS	0.0.0.0
DHCP Client	Disable
Spanning Tree Protocol (STP)	Disable

### LAN Information - IPv6

IP Address	N/A
Link-Local Address	fe80::8adc:96ff:fe3f:29e
Gateway	N/A
Primary DNS	N/A
Secondary DNS	N/A

**Figure 9. Device Status Page showing LAN Information**

- Network settings (IP Address, Subnet Mask, Gateway, Primary DNS, Secondary DNS, and DHCP Client) — To configure these settings, see [IP settings](#) on page 12.
- Spanning Tree Protocol (STP) status — See [Spanning Tree Protocol \(STP\) settings](#) on page 13.

## Connections

The WAP 100AC automatically keeps records (logs) of events in internal memory. To view these logs, click **Connections** in the Overview section of the left side bar (1).

WAP 100AC Dual Band Wireless Access Point Changes: 0 Reset Logout

Overview  
Device Status  
Connections  
Network  
Basic  
Wireless  
WPS  
Management  
Advanced  
Time Zone  
WiFi Scheduler  
Tools  
System Manager  
Account  
Firmware  
Log

English

### Connection List - 2.4GHz

SSID	MAC Address	TX	RX	RSSI	Block
------	-------------	----	----	------	-------

### Connection List - 5GHz

SSID	MAC Address	TX	RX	RSSI	Block
------	-------------	----	----	------	-------

Refresh

**Figure 10. Connections Page**

Click **Refresh** (2) to update the connection lists.

### NOTES:

- If there is not enough memory to store all events, more recent events over-write the oldest events.
- The log is cleared whenever the WAP 100AC is powered down or rebooted.

# Network

The Network section has three pages:

- **Basic**
- **Wireless**
- **WPS**

## Basic

Configure the WAP 100AC IP settings from the **Basic** page. To access this page, click **Basic** (1) in the **Network** section of the left side bar. This page allows you to configure:

- IP Settings (see figure 11, 2)
- **Spanning Tree Protocol (STP) settings** on page 13 (see **figure 12**, 1)

### IP settings

WAP 100AC Dual Band Wireless Access Point

Changes : 0    Reset    Logout

Overview    2 IPv4 Settings

Device Status

Connections

1 Network

Basic

Wireless

WPS

Management

Advanced

Time Zone

WiFi Scheduler

Tools

System Manager

Account

Firmware

Log

English

IP Network Setting     DHCP     Static IP

IP Address    192.168.1.1

Subnet Mask    255.255.255.0

Gateway    192.168.1.1

Primary DNS    0.0.0.0

Secondary DNS    0.0.0.0

IPv6 Settings     Link-Local Address

IP Address

Subnet Prefix Length

Gateway

Primary DNS

Secondary DNS

Spanning Tree Protocol (STP) Settings

**Figure 11. Network: Basic (IP Settings)**

Before configuring these settings, obtain the relevant information from your network administrator.

1. Choose **DHCP** or **Static IP**.
2. If you choose **DHCP**, all the addresses are obtained automatically when the WAP 100AC connects to a DHCP server.  
If you choose **Static IP**, you must enter values for **IP Address**, **Subnet Mask**, **Gateway**, **Primary DNS**, and **Secondary DNS**.
3. Click **Save** (see **figure 12**, 2, on page 13), to save the changes.

## Spanning Tree Protocol (STP) settings

Enabling the Spanning Tree protocol, prevents network loops. This panel allows you to configure the Spanning Tree settings (see figure 12, ❶).

The screenshot shows the Extron WAP 100AC web interface. The top header includes the Extron logo and the device name 'WAP 100AC Dual Band Wireless Access Point'. There are buttons for 'Changes : 0', 'Reset', and 'Logout'. The left navigation menu has categories: Overview, Device Status, Connections, Network (selected), Basic, Wireless, WPS, Management (expanded), Advanced, Time Zone, WiFi Scheduler, Tools, and System Manager. Under Management, 'Spanning Tree Protocol (STP) Settings' is selected. The main content area shows the following settings:

IP Address	
Subnet Prefix Length	
Gateway	
Primary DNS	
Secondary DNS	
<b>Spanning Tree Protocol (STP) Settings</b>	
Status	<input type="radio"/> Enable <input checked="" type="radio"/> Disable
Hello Time	2 seconds (1-10)
Max Age	20 seconds (6-40)
Forward Delay	15 seconds (4-30)
Priority	32768 (0-65535)

At the bottom of the settings area, there is a 'Save' button with the text 'Save current setting(s)' next to it, which is highlighted with a circled '2'.

**Figure 12. Network: Basic (Spanning Tree Protocol Settings)**

1. Select a radio button to **Enable** or **Disable** the Spanning Tree function.
2. If you enabled the Spanning Tree function, configure the other settings:
  - **Hello Time** — Select a value between **1** and **10** seconds. This value determines how often the device sends handshake packets to communicate information about the topology throughout the entire bridged LAN.
  - **Max Age** — Select a value between **6** and **40** seconds. If another bridge in the spanning tree does not send a Hello packet in this time, that device is assumed to be inactive.
  - **Forward Delay** — Select a value between **4** and **30** seconds. This value determines the time spent in each of the Listening and Learning states before entering the Forwarding state. The delay ensures that when a new bridge is added to a busy network, it analyzes data traffic before participating.
  - **Priority** — Specify a value between **0** and **65535**. The lower the number, the higher the priority.
3. Click **Save** (see figure 12, ❷) to save changes.

## Wireless

To access the Wireless page, click **Wireless** in the Network section of the left side bar (see figure 13, ❶). There are six panels to the Wireless page:

- Wireless Settings (see below)
- **2.4GHz and 5GHz settings** (see page 15)
- **SSID profile** (see page 16)
- **Guest network** (see page 17)
- **Fast Handover** (see page 18)
- **Management VLAN settings** (see page 18)

### Wireless settings

Extron.

WAP 100AC Dual Band Wireless Access Point Changes: 0 Reset Logout

Overview  
Device Status  
Connections  
Network  
❶ Basic  
Wireless  
WPS  
Management  
Advanced  
Time Zone  
WiFi Scheduler  
Tools  
System Manager  
Account  
Firmware  
Log

English

#### Wireless Settings

Device Name: WAP 100AC  
Country/Region: USA  
Band Steering:  Enable  Disable  
**NOTE:** In order for Band Steering function to work properly, both 2.4GHz and 5GHz SSID and Security Settings must be the same.

	2.4GHz	5GHz
Operation Mode	Access Point <input checked="" type="checkbox"/> Green	Access Point <input checked="" type="checkbox"/> Green
Wireless Mode	802.11 B/G/N	802.11 AC/N
Channel HT Mode	20/40MHz	80MHz(AC Only)
Extension Channel	Upper Channel	Lower Channel
Channel	Auto	Auto
Transmit Power	Auto	Auto
Data Rate	Auto	Auto
RTS / CTS Threshold (1 - 2346)	2346	2346
Client Limit	127 <input checked="" type="radio"/> Enable <input type="radio"/> Disable	127 <input checked="" type="radio"/> Enable <input type="radio"/> Disable
Annunciation	<input checked="" type="radio"/> Enable <input type="radio"/> Disable	32 Frames

**Figure 13. Network: Wireless (Settings)**

- **Device Name** — Enter a name for the device. This is the name used by SNMP Management (see **Advanced** on page 20). It is not the SSID and it is not broadcast to other devices.
- **Country/Region** — Select a country or region to conform to local regulations.
- **Band Steering** — With Band Steering enabled, 802.11n clients use the 5 GHz band (which 802.11b/g clients cannot use). 802.11b/g clients use the 2.4 GHz band.

**NOTE:** For the Band Steering function to work correctly, both the 2.4 GHz and 5 GHz SSID and security settings must be the same.

Click **Save** at the bottom of the web page (see **figure 17**, ❶, on page 18) to save the changes.

## 2.4GHz and 5GHz settings

Configure the 2.4 GHz (Figure 14, ①) and 5 GHz (②) band settings separately.

Extron  
WAP 100AC Dual Band Wireless Access Point Changes : 0 Reset Logout

① 2.4GHz ② 5GHz

Operation Mode	Access Point	<input checked="" type="checkbox"/> Green	Access Point	<input checked="" type="checkbox"/> Green
Wireless Mode	802.11 B/G/N		802.11 AC/N	
Channel HT Mode	20/40MHz		80MHz(AC Only)	
Extension Channel	Upper Channel		Lower Channel	
Channel	Auto		Auto	
Transmit Power	Auto		Auto	
Data Rate	Auto		Auto	
RTS / CTS Threshold (1 - 2346)	2346		2346	
Client Limit	127	<input checked="" type="radio"/> Enable <input type="radio"/> Disable	127	<input checked="" type="radio"/> Enable <input type="radio"/> Disable
Aggregation	32	<input checked="" type="radio"/> Enable <input type="radio"/> Disable		
	50000	Bytes(Max)		
AP Detection	Scan		Scan	

Wireless Settings - 2.4GHz

No.	Enable	SSID	Edit	Security	Hidden SSID	Client Isolation	VLAN Isolation	VLAN ID
-----	--------	------	------	----------	-------------	------------------	----------------	---------

**Figure 14. Network: Wireless (2.4GHz and 5 GHz Settings)**

- **Operation Mode** — Use the drop-down menu to select from the three operating modes:
  - **Access Point** — The WAP 100AC acts as a central connection for wireless clients.
  - **WDS AP** (Wireless Distribution System Access Point) — The WAP 100AC connects to both wireless clients and other wireless access points.
  - **WDS Bridge** — The WAP 100AC connects only with other wireless access points. In this mode, the device does not act as an access point.

For more information, see [Building a Wireless Network](#) on page 31.

- **Green check box** — When this box is checked, **Transmit Power** of the wireless signal is set to auto (see below). When the box is unchecked, the Transmit Power of the wireless signal can be set by the user.
- **Wireless Mode** — Use these drop-down menus to decide which wireless mode each band uses. The 2.4 GHz band supports 802.11b/g/n mixed mode. The 5 GHz band supports 802.11ac/a/n mixed mode.
- **Channel HT Mode** — Specify which modes are supported by each band. By default, this is **20/40/80 MHz**. The larger the channel, the better the transmission quality and speed.
- **Extension Channel** — Select either **Upper** or **Lower**. This selection may affect the Auto Channel function
- **Channel** — Select the channel and frequency that conforms to the regulations for your country.
  - Select **Auto** to enable the Auto-Channel feature.
  - The 5.15 - 5.35 GHz range is restricted to indoor use in Hong Kong.
- **Transmit Power** — If the **Green check box** is not selected, the power output of the wireless signal can be set.
- **Data Rate** — Set the data rate from the drop-down menu. The lower the data rate, the lower the throughput, although transmission distance is also lowered.
- **RTS/CTS Threshold** — Select the threshold package size for RTS/CTS (Request to Send/Clear to Send). The smaller the number, the more frequently RTS/CTS packets are sent, which uses more bandwidth.
- **Client Limit** — Enter the total number of clients for the access point.

- **Aggregation** — Enable **Aggregation** to merge smaller data packets into one larger packet. This reduces the number of packets but increases packet size. Select **Enable** or **Disable**. If **Aggregation** is enabled, enter the number of frames and the maximum packet size (also see **Management VLAN settings** on page 18).
- **AP Detection** — Click **Scan** to detect nearby access points. This enables the device to select the best channel to use.

Click **Save** at the bottom of the page (see **figure 17**, ❶, on page 18) to save the changes.

## SSID profile

These panels allow you to edit the SSID profile. Click **Edit** next to the SSID that you wish to change.

The screenshot shows the configuration interface for an Extron WAP 100AC Dual Band Wireless Access Point. The page is titled "WAP 100AC Dual Band Wireless Access Point" and includes a navigation menu on the left with options like Overview, Network, Management, and System Manager. The main content area is divided into two sections: "Wireless Settings - 2.4GHz" (marked with a circled 1) and "Wireless Settings - 5GHz" (marked with a circled 2). Each section contains a table of SSID profiles with columns for No., Enable, SSID, Edit, Security, Hidden SSID, Client Isolation, VLAN Isolation, and VLAN ID.

Wireless Settings - 2.4GHz								
No.	Enable	SSID	Edit	Security	Hidden SSID	Client Isolation	VLAN Isolation	VLAN ID
1	<input checked="" type="checkbox"/>	WAP-100AC-3F-02-9F_1-2.4G	<a href="#">Edit</a>	None	<input type="checkbox"/>	<input type="checkbox"/>	<input type="checkbox"/>	1
2	<input type="checkbox"/>	WAP-100AC-3F-02-9F_2-2.4G	<a href="#">Edit</a>	None	<input type="checkbox"/>	<input type="checkbox"/>	<input type="checkbox"/>	2
3	<input type="checkbox"/>	WAP-100AC-3F-02-9F_3-2.4G	<a href="#">Edit</a>	None	<input type="checkbox"/>	<input type="checkbox"/>	<input type="checkbox"/>	3
4	<input type="checkbox"/>	WAP-100AC-3F-02-9F_4-2.4G	<a href="#">Edit</a>	None	<input type="checkbox"/>	<input type="checkbox"/>	<input type="checkbox"/>	4
5	<input type="checkbox"/>	WAP-100AC-3F-02-9F_5-2.4G	<a href="#">Edit</a>	None	<input type="checkbox"/>	<input type="checkbox"/>	<input type="checkbox"/>	5
6	<input type="checkbox"/>	WAP-100AC-3F-02-9F_6-2.4G	<a href="#">Edit</a>	None	<input type="checkbox"/>	<input type="checkbox"/>	<input type="checkbox"/>	6
7	<input type="checkbox"/>	WAP-100AC-3F-02-9F_7-2.4G	<a href="#">Edit</a>	None	<input type="checkbox"/>	<input type="checkbox"/>	<input type="checkbox"/>	7
8	<input type="checkbox"/>	WAP-100AC-3F-02-9F_8-2.4G	<a href="#">Edit</a>	None	<input type="checkbox"/>	<input type="checkbox"/>	<input type="checkbox"/>	8

Wireless Settings - 5GHz								
No.	Enable	SSID	Edit	Security	Hidden SSID	Client Isolation	VLAN Isolation	VLAN ID
1	<input checked="" type="checkbox"/>	WAP-100AC-3F-02-A0_1-5GH	<a href="#">Edit</a>	None	<input type="checkbox"/>	<input type="checkbox"/>	<input type="checkbox"/>	51
2	<input type="checkbox"/>	WAP-100AC-3F-02-A0_2-5GH	<a href="#">Edit</a>	None	<input type="checkbox"/>	<input type="checkbox"/>	<input type="checkbox"/>	52
3	<input type="checkbox"/>	WAP-100AC-3F-02-A0_3-5GH	<a href="#">Edit</a>	None	<input type="checkbox"/>	<input type="checkbox"/>	<input type="checkbox"/>	53
4	<input type="checkbox"/>	WAP-100AC-3F-02-A0_4-5GH	<a href="#">Edit</a>	None	<input type="checkbox"/>	<input type="checkbox"/>	<input type="checkbox"/>	54

**Figure 15. 2.4 GHz and 5 GHz SSID Profile**

- **SSID** — This column specifies the Service Set Identifier (SSID) for the current profile. Click **Edit** to change the Wireless Security settings (See **Security Settings** on page 34).
- **Security** — See **Security Settings** on page 34.
- **Hidden SSID** — Check this box to hide the SSID from clients. If it is checked, the SSID does not appear on the site survey.
- **Client Isolation** — Check this box to prevent communication between client devices. Leaving the box unchecked allows communication between client devices.
- **VLAN Isolation** — Check this box to enable the VLAN Isolation feature. Leaving the box unchecked disables the feature.

**NOTE:** For more information about the Isolation modes, click the appropriate information icon.

- **VLAN ID** — See **Management VLAN settings** on page 18.

Click **Save** at the bottom of the page (see **figure 17**, ❶) to save the changes.

## Guest network

A guest network allows visitors to use the internet without compromising your office or company wireless security. You can add a guest network to each wireless network in the 2.4 GHz and 5 GHz frequencies.

The screenshot shows the 'Guest Network Settings' page in the Extron WAP 100AC web interface. The page has a dark blue header with the Extron logo and 'WAP 100AC Dual Band Wireless Access Point'. Below the header are buttons for 'Changes : 2', 'Reset', and 'Logout'. A left-hand navigation menu includes 'Overview', 'Device Status', 'Connections', 'Network', 'Basic', 'Wireless', 'WPS', 'Management', 'Advanced', 'Time Zone', 'WiFi Scheduler', 'Tools', 'System Manager', 'Account', 'Firmware', and 'Log'. The main content area is titled 'Guest Network Settings' and contains a table for configuring guest networks. The table has columns for 'Enable', 'SSID', 'Edit', 'Security', 'Hidden SSID', and 'Client Isolation'. Below the table are sections for 'Manual IP Settings', 'Automatic DHCP Server Settings', and 'Fast Handover'.

Enable	SSID	Edit	Security	Hidden SSID	Client Isolation
<input type="checkbox"/>	Extron-2.4GHz_GuestNetwork	Edit	None	<input type="checkbox"/>	<input checked="" type="checkbox"/>
<input type="checkbox"/>	Extron-5GHz_GuestNetwork	Edit	None	<input type="checkbox"/>	<input checked="" type="checkbox"/>

Manual IP Settings

- IP Address: 192.168.200.1  
- Subnet Mask: 255.255.255.0

Automatic DHCP Server Settings

- Starting IP Address: 192.168.200.100  
- Ending IP Address: 192.168.200.200  
- WINS Server IP: 0.0.0.0

Fast Handover

Status:  Enable  Disable  
RSSI: -85 dBm (Range: -60dBm ~ -100dBm)

**Figure 16. Guest Network Settings**

- **SSID** — This column specifies the Service Set Identifier (SSID) for the current profile.
- **Security** — See [Security Settings](#) on page 34.
- **Hidden SSID** — Check this box to hid the SSID from clients. If it is checked, the SSID does not appear on the site survey.
- **Client Isolation** — Check this box to prevent communication between client devices. Leaving the box unchecked allows communication between client devices.
- **IP Address** — The IP address of the WAP 100AC.
- **Subnet Mask** — The IP subnet mask of the WAP 100AC.
- **Starting IP Address** — The first IP address in the range of IP addresses made available by the DHCP server.
- **Ending IP Address** — The last IP address in the range of IP addresses made available by the DHCP server.
- **WINS Server IP** — The IP address on the Windows Internet Name Server (WINS).

Click **Save** at the bottom of the page (see [figure 17](#), **1**, on the next page) to save the changes.

## Fast Handover

The Fast Handover feature ensures that each client is served by at least one access point at all times. Access points continuously monitor the connectivity quality of any client within their range and share this information efficiently with other access points in the vicinity of the client to ensure the best service for that client.

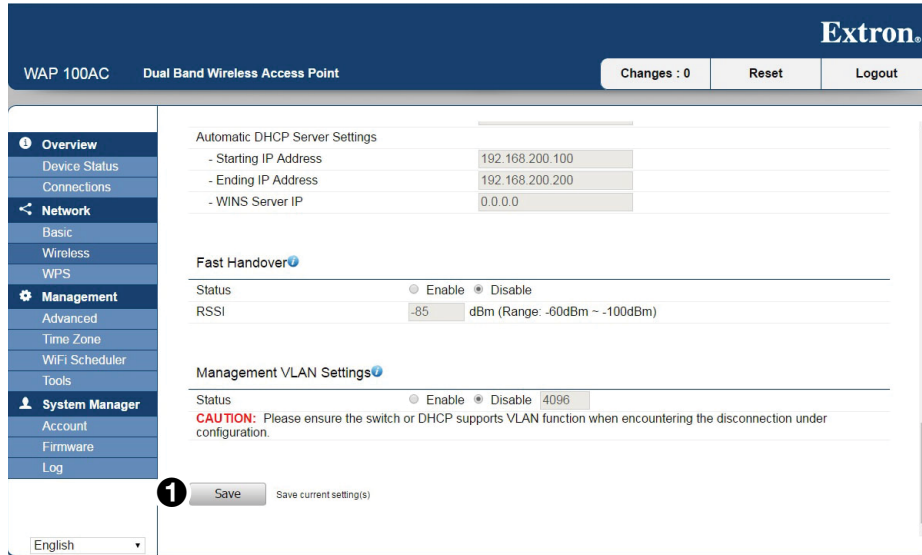

**Figure 17. Fast Handover and Management VLAN Settings**

- **Status** — Select **Enable** or **Disable** to set the status of the Fast Handover feature.
- **RSSI** — Enter the Received Signal Strength Index (RSSI) to determine the handover procedure that the current wireless link terminates. RSSI is an indication of the power level received by the antenna. The higher the RSSI number, the stronger the signal.

Click **Save** (see figure 17, **1**) to save the changes.

## Management VLAN settings

A Virtual LAN (VLAN) is a group of computers on a network that have been configured to behave as if they were on a separate LAN. Computers on a VLAN do not have to be physically located next to one another.

The **Management VLAN Settings** allow you to assign a VLAN tag to the packets.

Before enabling the Management VLAN settings, you must isolate and enter a VLAN ID in the **SSID profile** section (see page 16).

1. Check the Isolation box for the SSID you wish to select (see figure 18, **1**).

The screenshot shows a table titled "Wireless Settings - 2.4GHz" with columns: No., Enable, SSID, Edit, Security, Hidden SSID, Client Isolation, VLAN Isolation, and VLAN ID. A circled "1" is next to the "Client Isolation" column and a circled "2" is next to the "VLAN ID" column. The table contains one row with the following data:

No.	Enable	SSID	Edit	Security	Hidden SSID	Client Isolation	VLAN Isolation	VLAN ID
1	<input checked="" type="checkbox"/>	WAP-100AC-3F-02-9F-1-2.4G	Edit	None	<input type="checkbox"/>	<input checked="" type="checkbox"/>	<input checked="" type="checkbox"/>	1

**Figure 18. Isolating a VLAN and Entering a VLAN ID**

2. Enter a VLAN ID (**2**).
3. Select the Management VLAN Settings Status **Enable** radio button.
4. Specify a VLAN ID for packets passing through the access point with a tag.
5. Click **Save** (see figure 17, **1**) to save the changes.

**NOTE:** If you reconfigure the Management VLAN ID, you may lose your connection to the WAP 100AC. Verify that the DHCP server supports the reconfigured VLAN ID and reconnect to the WAP 100AC using the new IP address.

## WPS

The Wi-Fi Protected Setup (WPS) feature complies with the Wi-Fi Alliance WPS standard and makes it easier and quicker to add client devices to an established, security-enabled Wi-Fi network.

WPS reduces the number of steps required to configure a network and supports two methods that are familiar to most consumers for configuring a network and enabling security.

**NOTE:** The WPS feature can only be applied when the unit is in Access Point and WDS AP modes.

The screenshot shows the Extron WAP 100AC web interface. The top navigation bar includes the Extron logo, the device name 'WAP 100AC Dual Band Wireless Access Point', and buttons for 'Changes : 2', 'Reset', and 'Logout'. A left sidebar menu contains options like Overview, Device Status, Connections, Network, Basic, Wireless, WPS, Management, Advanced, Time Zone, WiFi Scheduler, Tools, System Manager, Account, Firmware, and Log. The main content area is titled 'WPS Settings - 2.4GHz' and 'WPS Settings - 5GHz'. Each section has a 'Status' field with radio buttons for 'Enable' and 'Disable'. The 'Current Configuration' field shows 'Configured' with a 'Release Configuration' button. Other fields include 'Self-Pin Code' (32914610), 'SSID' (WAP-100AC-3F-02-9F\_1-2.4GHz for 2.4GHz and WAP-100AC-3F-02-A0\_1-5GHz for 5GHz), 'Authentication Mode' (None), and 'Encryption Key' (None). There are 'Start' buttons for 'WPS via Push Button' and 'WPS via Pin'. A 'Save' button is located at the bottom of each section.

**Figure 19. Network: WPS Page**

Configure the 2.4 GHz, 5 GHz, or both settings.

- **Status** — Select **Enable** to use the WPS feature.
- **Current Configuration** — This field is read-only shows whether the WPS function is Configured or Unconfigured.  
When it is configured, WPS has been used to authorize a connection between the device and wireless clients.
- **Self-Pin Code** — This is the PIN code for this WAP 100AC unit.
- **SSID** — This is the SSID (wireless network name) used to connect via WPS.
- **Authentication Mode** — This shows the encryption method used by the WPS process.
- **Encryption Key** — This key is randomly generated during the WPS process. It is required if wireless clients that do not support WPS try to connect to the wireless network.
- **WPS via Push Button** — Click this **start** button to initialize the WPS feature by using the Push Button method.
- **WPS via Pin** — Enter the PIN code of the wireless device and press this **start** button to initialize the WPS feature by using the PIN method.

Click **Save** to save the changes.

# Management

## Advanced

To access the **Advanced Management** page, click **Advanced** in the **Management** section of the left side bar (see figure 20, ❶). This page allows you to assign contact details, location, community name, and trap settings for Simple Network Management Protocol (SNMP).

SNMP is a networking management protocol that is used to monitor network-attached devices. SNMP allows messages (protocol data units) to be sent to various parts of the network. Upon receiving the messages, SNMP-compatible devices return data stored in their Management Information Bases.

The screenshot shows the Extron WAP 100AC Advanced Management page. The left sidebar contains a navigation menu with the following items: Overview, Device Status, Connections, Network (Basic, Wireless, WPS), Management (Advanced, Time Zone, WiFi Scheduler, Tools), System Manager (Account, Firmware, Log), and a language dropdown set to English. The main content area is titled 'SNMP Settings' and includes the following fields:

Field	Value
Status	<input checked="" type="radio"/> Enable <input type="radio"/> Disable
Contact	
Location	
Port	161
Community Name (Read Only)	public
Community Name (Read Write)	private
Trap Destination	
- Port	162
- IP Address	
- Community Name	public
SNMPv3 Settings	
- Status	<input checked="" type="radio"/> Enable <input type="radio"/> Disable
- Username	admin (1-31 Characters)
- Authorized Protocol	MD5
- Authorized Key	12345678 (8-32 Characters)
- Private Protocol	DES
- Private Key	12345678 (8-32 Characters)
- Engine ID	

**Figure 20. Management: Advanced Page — SNMP Settings**

- **Status** — Select a radio button to **Enable** or **Disable** the SNMP feature.
- **Contact** — Specify the **Contact** details of the device.
- **Location** — Specify the **Location** of the device.
- **Port** — Displays the **Port** number used for SNMP communications.
- **Community Name (Read Only)** — Specify the password for the SNMP community for read-only access.
- **Community Name (Read Write)** — Specify the password for the SNMP community for read/write access.
- **Trap Destination** — Specify the **Port** and **IP Address** of the computer that receives the SNMP traps and the password for the SNMP trap **Community Name**.
- **SNMP v3 Status** — Enables or Disables the SNMP v3 feature.
- **Username** — Specify the **Username** for the SNMP v3 feature.
- **Authorized Protocol** — Select the **Authentication Protocol** type: either **MD5** or **SHA**.
- **Authorized Key** — Specify the **Authentication Key** for authentication.
- **Private Protocol** — Select the **Private Protocol** type: **DES**.
- **Private Key** — Specify the **Private Key**.
- **Engine ID** — Specify the **Engine ID** for SNMP v3.
- **Apply** — Click **Apply** to save the changes. The **Apply** button is below the **SNMP** settings (it is not shown in figure 20).

## Time Zone

To access the **Date and Time Settings** page, click **Time Zone** in the **Management** section of the left side bar (see figure 21). This page allows you to set the WAP 100AC internal clock.

The screenshot displays the Extron WAP 100AC management interface. The top navigation bar includes the Extron logo, 'WAP 100AC Dual Band Wireless Access Point', and buttons for 'Changes : 2', 'Reset', and 'Logout'. The left sidebar lists various management sections: Overview, Device Status, Connections, Network, Basic, Wireless, WPS, Management (selected), Advanced, Time Zone, WiFi Scheduler, Tools, System Manager, Account, Firmware, and Log. The main content area is titled 'Date and Time Settings' and features two radio buttons: 'Manually Set Date and Time' (selected) and 'Automatically Get Date and Time'. Under 'Manually Set Date and Time', there are input fields for Date (2016 / 05 / 17) and Time (08 : 25 (24-Hour)), along with a 'Synchronize with PC' button. Under 'Automatically Get Date and Time', there is an 'NTP Server' field with the value 'pool.ntp.org'. Below this is the 'Time Zone' section, which includes a drop-down menu set to 'UTC+00:00 Gambia, Liberia, Morocco', a checkbox for 'Enable Daylight Saving', and two rows of time selection fields for 'Start Time' (January 1st Sun 12 am) and 'End Time' (January 1st Mon 12 am). An 'Apply' button is located at the bottom of the settings area.

**Figure 21. Management: Time Zone Page**

1. Select either the **Manually Set Date and Time** or **Automatically Get Date and Time** radio button.
  - If you chose to set the date and time manually, enter the date (YYYY/MM/DD) and time (using a 24-hour clock).
  - Alternatively, click **Synchronize with PC** to synchronize the WAP 100AC date and time with your PC.
  - If you chose to set the date and time automatically, enter the IP address of an NTP server or use the default NTP server.
2. Choose your **Time Zone** from the drop-down menu.
3. Check the checkbox if you wish to **Enable Daylight Saving**.
4. Enter the start and end times for daylight saving time in your location.
5. Click **Apply** to save the changes.

## WiFi Scheduler

To access the WiFi Scheduler page, click **WiFi Scheduler** in the **Management** section of the left side bar (see figure 22, ❶). This page allows you to schedule the frequency of system reboots.

WAP 100AC Dual Band Wireless Access Point Changes : 2 Reset Logout

**Overview**

- Device Status
- Connections
- Network
  - Basic
  - Wireless
  - WPS
- Management
  - Advanced
  - Time Zone
  - ❶ WiFi Scheduler
  - Tools
- System Manager
  - Account
  - Firmware
  - Log

English

### Auto Reboot Settings

Status:  Enable  Disable

Timer:  Sunday  Monday  Tuesday  Wednesday  Thursday  Friday  Saturday

0 : 0

### WiFi Scheduler

Status:  Enable  Disable

**NOTE:** Please assure that the Time Zone Settings is synced with your local time when enabling the Wi-Fi Scheduler.

Wireless Radio: 2.4GHz

SSID Selection: WAP-100AC-3F-02-9F\_1-2.4GHz

Schedule Templates: Choose a template

Day	Availability	Duration
Sunday	available	00 : 00 ~ 24 : 00
Monday	available	00 : 00 ~ 24 : 00
Tuesday	available	00 : 00 ~ 24 : 00
Wednesday	available	00 : 00 ~ 24 : 00
Thursday	available	00 : 00 ~ 24 : 00

Schedule Table

**Figure 22. Management: Wi-Fi Scheduler Page**

### Auto Reboot settings

Use this panel to set up a schedule when the WAP 100AC reboots automatically.

- **Status** — To enable the Auto Reboot function, select the **Enable** radio button.
- **Timer** — If the Auto Reboot function is enabled, check one or more boxes to select the days of the week when the device reboots.

Use the two text boxes to enter the hours (❷) and minutes (❸) of the time when the device reboots. This function uses a 24-hour clock.

Scroll to the bottom of the page and click **Save** (not shown) to apply the schedule.

### Wi-Fi scheduler

Use this panel to set the days and times when the WAP 100AC is available to the network.

- **Wireless Radio** — Select either **2.4 GHz** or **5.0 GHz**.
- **SSID Selection** — Select the SSID of the device to be scheduled.
- **Schedule Templates** — Select **Always Available**, **Available Daily**, **Available Daily except Weekends**, or **Custom**.
- **Schedule Table** — Select the availability status and the start and finish time. This function uses a 24-hour clock.

Scroll to the bottom of the page and click **Save** (not shown) to apply the schedule.

## Tools

To access the Tools page, click **Tools** in the **Management** section of the left side bar (see figure 23, ①). Use this page to analyze the connection quality of the WAP 100AC and trace the routing table to a target in the network, with the following tools: Ping test parameters (see below), **Traceroute test parameters** (see page 24), and **Speed test parameters** (see page 25). This page also allows **LED control** (see page 26) and **Device discovery** (see page 26).

### Ping test parameters

The screenshot shows the Extron WAP 100AC management interface. The top header includes the Extron logo, the device name 'WAP 100AC Dual Band Wireless Access Point', and buttons for 'Changes : 0', 'Reset', and 'Logout'. The left sidebar contains navigation menus for Overview, Network, Management, Tools (marked with a circled '1'), and System Manager. The main content area is titled 'Ping Test Parameters' and contains two sections. The first section, 'Ping Test Parameters', has input fields for 'Target IP / Domain Name', 'Ping Packet Size' (set to 64 Bytes), and 'Number of Pings' (set to 4), with a 'Start' button below. The second section, 'Traceroute Test Parameters', has a 'Target IP / Domain Name' field and 'Start' and 'Stop' buttons. A language dropdown menu is visible at the bottom left of the interface.

**Figure 23. Management: Tools Page — Ping Test Parameters**

The Ping test measures how long it takes for a packet of information to travel from the client computer to a specified server.

- **Target IP/Domain Name** — Enter the IP address or domain name that you are targeting.
- **Ping Packet Size** — Enter the packet size of each ping (see below).
- **Number of Pings** — Enter the number of times you wish to ping.
- **Start** — Click **Start** to ping the target device by IP. The results appear in the text box.

## Traceroute test parameters

The screenshot shows the management interface for an Extron WAP 100AC Dual Band Wireless Access Point. The page title is "Traceroute Test Parameters". The interface includes a navigation menu on the left with categories: Overview, Network, Management, and System Manager. The main content area is divided into two sections: "Traceroute Test Parameters" and "Speed Test Parameters".

**Traceroute Test Parameters**

Target IP / Domain Name	<input type="text"/>
<input type="button" value="Start"/>	<input type="button" value="Stop"/>
<div style="border: 1px solid #ccc; height: 100px;"></div>	

**Speed Test Parameters**

Target IP / Domain Name	<input type="text"/>	
Time Period	<input type="text" value="20"/>	Sec
Check Interval	<input type="text" value="5"/>	Sec
<input type="button" value="Start"/>	<input type="text"/>	

English

**Figure 24. Management: Tools Page — Traceroute Test Parameters**

The Traceroute test shows the path taken by a packet of information from the client computer to another, specified computer. It lists all the routers it passes through until it either reaches the other computer, or is discarded.

- **Target IP/Domain Name** — Enter the IP address or domain name of the target computer.
- **Start** — Click **Start** to begin the Traceroute test. The results appear in the large text box.
- **Stop** — Click **Stop** to end the Traceroute test.

## Speed test parameters

WAP 100AC Dual Band Wireless Access Point

Changes : 0 Reset Logout

Extron

Overview

Device Status

Connections

Network

Basic

Wireless

WPS

Management

Advanced

Time Zone

WiFi Scheduler

Tools

System Manager

Account

Firmware

Log

English

### Speed Test Parameters

Target IP / Domain Name

Time Period 20 Sec

Check Interval 5 Sec

Start

IPv4 Port 5001

IPv6 Port 5002

LED Control

Power  Enable  Disable

LAN  Enable  Disable

**Figure 25. Management: Tools Page — Speed Test Parameters**

The Speed test measures:

- **Ping** — The round-trip time taken for a server to reply to a request from the client PC.
- **Download speed** — The speed taken for an initial data packet to be transferred from the server to the client PC using port **8080**.
- **Upload speed** — The speed taken for data packets to be transferred from the client computer to the server using the ports shown.

To run a speed test, carry out the following:

- **Target IP/Domain Name** — Enter the IP address or domain name of the target computer.
- **Time Period** — Enter the length of time for which the test is carried out.
- **Check Interval** — Enter the length of time for each individual check carried out in the test. For example, figure 25 shows that the test is carried out for 20 seconds, with each individual check taking 5 seconds. Under these conditions, four checks are carried out during the test.
- **Start** — Scroll to the bottom of the page and click **Start** (not shown) to begin the Speed test. The results are shown in the large text box.

## LED control

The screenshot shows the Extron WAP 100AC management interface. The top navigation bar includes the Extron logo, the device name 'WAP 100AC Dual Band Wireless Access Point', and buttons for 'Changes : 0', 'Reset', and 'Logout'. A left sidebar contains a menu with categories: Overview, Network, Management, and System Manager. The main content area is titled 'LED Control' and features five rows of settings, each with 'Enable' and 'Disable' radio buttons. Below these is an 'Apply' button and a note: 'Apply saved settings to take effect'. The 'Device Discovery' section contains a table with columns for 'Device Name', 'Operation Mode', 'IP Address', 'System MAC Address', and 'Firmware Version', and a 'Scan' button below it. A language dropdown menu at the bottom left is set to 'English'.

LED Control	
Power	<input checked="" type="radio"/> Enable <input type="radio"/> Disable
LAN	<input checked="" type="radio"/> Enable <input type="radio"/> Disable
WLAN-2.4GHz	<input checked="" type="radio"/> Enable <input type="radio"/> Disable
WLAN-5GHz	<input checked="" type="radio"/> Enable <input type="radio"/> Disable
WPS	<input checked="" type="radio"/> Enable <input type="radio"/> Disable

Device Discovery				
Device Name	Operation Mode	IP Address	System MAC Address	Firmware Version
<input type="button" value="Scan"/>				

**Figure 26. Management: Tools Page — LED Control and Device Discovery**

The LED Control section allows you to **Enable** or **Disable** the five LEDs of the WAP 100AC bottom panel (see [figure 4](#) on page 7).

Click **Apply** for the new settings to take effect.

### Device discovery

The Device Discovery function scans for local devices that the WAP 100AC can connect to.

Click **Scan** to start device discovery.

# System Manager

## Account

To access the **Account** page, click **Account** in the **System Manager** section of the left side bar (see figure 27, ❶). This page allows you to reset the account password.

**NOTES:**

- The factory configured passwords for all accounts on this device have been set to the device serial number. Passwords are case sensitive.
- If the device is reset to default settings, the passwords are reset to the default password, which is **extron** (for either **admin** or **user**).

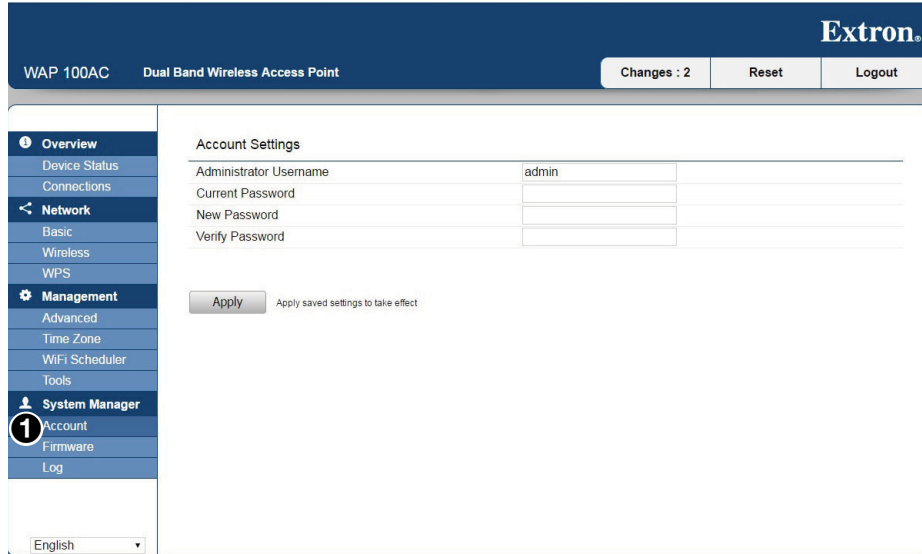

**Figure 27. System Manager: Account Page**

1. If you wish, enter a new Administrator Username.
2. Enter the Current Password (see Notes above).
3. Enter the New Password.
4. Enter the new password a second time to Verify Password.
5. Click **Apply** for the new settings to take effect.

**NOTES:**

- The password can have 0 through 12 alphanumeric characters and is case sensitive.
- Extron strongly recommends that you change the password for greater security.

## Firmware

Before you can upload firmware to the WAP 100AC, read the firmware release notes to determine whether the new version of the firmware corrects an existing bug or provides a new feature that you need.

If you decide to update the firmware, you must first download the appropriate file from the Extron website to a PC on the same subnetwork as the WAP 100AC. You can then upload the firmware to the WAP 100AC using the internal web pages.

### Downloading firmware to a PC

1. On your PC, go to [www.extron.com](http://www.extron.com) and click **Download** in the menu bar along the top of the page (see figure 28, ①).

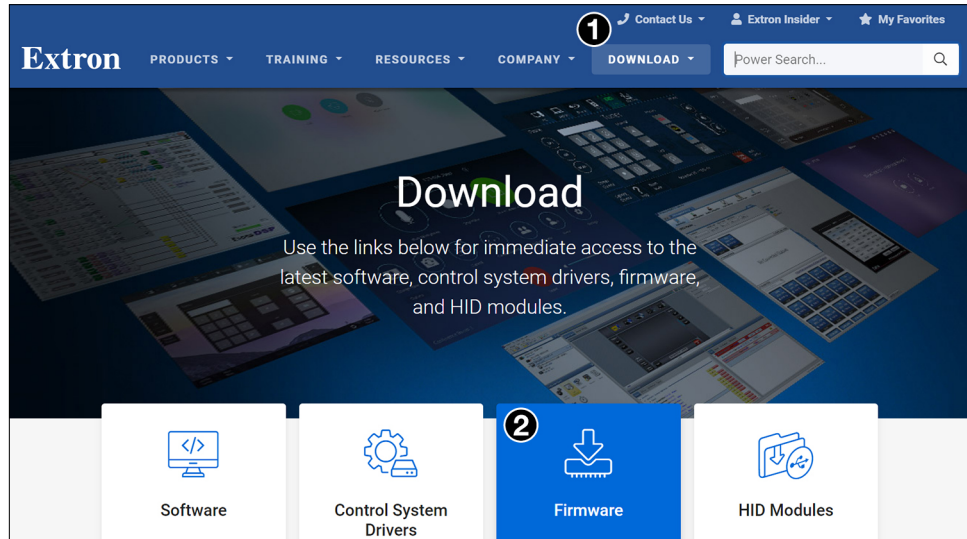

Figure 28. Firmware Download Center

2. Click **Firmware** at the bottom of the page (②). The firmware Download Center opens:

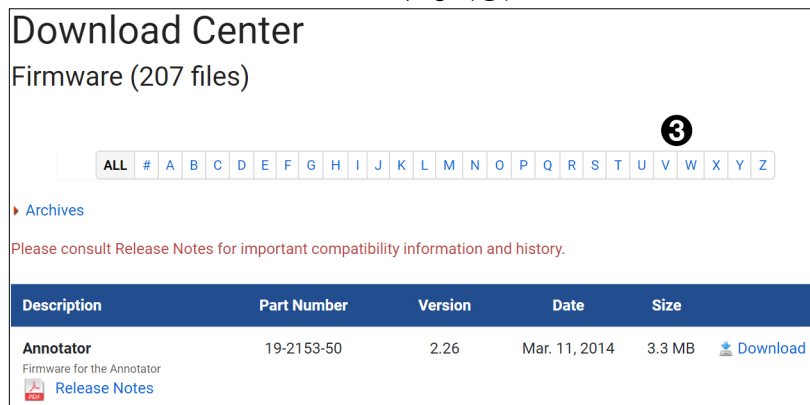

Figure 29. Firmware Download Center

3. Click the letter **W** from the alphabet menu (see figure 29, ③).
4. Scroll down the page until you find the firmware for the WAP 100AC.

**NOTE:** The product is listed on this page only when there has been an update to the original firmware.

5. Click **Release Notes** for more information about the firmware to decide whether the firmware upgrade corrects an existing bug or provides a new feature that you want to use.
6. If you decide to upgrade, click **Download**.

7. Follow the onscreen instructions to download the program. The **Firmware InstallShield Wizard** guides you through the steps of downloading the executable file (.exe), unpackaging and installing the firmware on your PC.
8. Make a note of where the firmware is saved.

## Uploading firmware to the WAP 100AC

Use the WAP 100AC internal web pages to upload the firmware. To access the **Firmware** page, click **Firmware** in the **System Manager** section of the left side bar (figure 30, ❶). This page allows you to upload a more recent version of the firmware to the WAP 100AC.

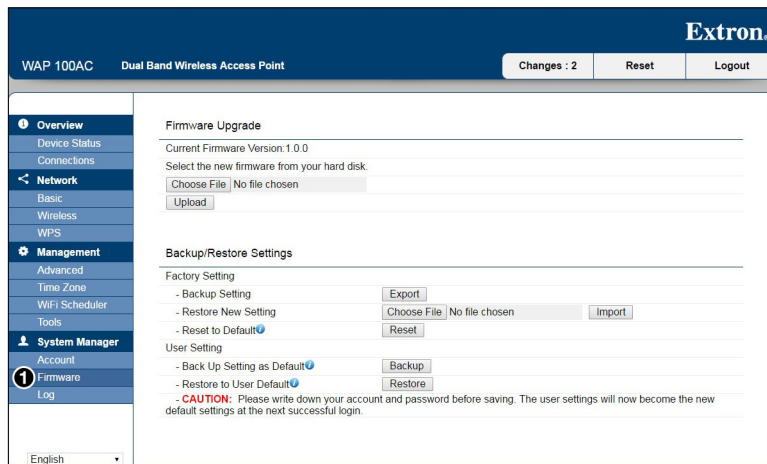

**Figure 30. System Manager: Firmware Page**

1. Click **Choose File** and navigate to the folder where you saved the firmware (see [step 8](#), in the previous section).
2. Select the firmware file. The name of the file appears in the **Firmware Upgrade** field.
3. Click **Upload**.

**NOTE:** The WAP 100AC is unavailable while the firmware is being updated. When the update is complete, the unit must reboot and any connections to or through the device are lost.

## Backup and restore settings

If problems occur, it is useful to have a system configuration that is known to work. From this page you can choose from the following:

- Use a previously saved configuration to replace the existing configuration.
- Save the current configuration for future use as a backup
- Reset the configuration to the factory default values.

### Factory settings

**Backup Settings** — To restore settings that have previously been backed up.

1. Click **Export**.
2. Navigate to the folder with the saved file.
3. Click **Restore**.

**Restore New Setting** — To choose a file

1. Click **Choose File**.
2. Navigate to the file that you wish to import.
3. Click **Import**.

**Reset to Default** — Click **Reset** to restore the unit to the factory default settings.

## User settings

**Back Up Setting as Default** — Click **Backup** to save the user settings that you want as the default settings (see [figure 30](#), on the previous page).

**Restore to User Default** — Click **Restore** to restore user settings to the factory standard settings.

**NOTE:** Remember to save your account name and password as the User Settings become the new default settings when you next log in.

## Log

To access the **Log** page, click **Log** in the **System Manager** section of the left side bar (see [figure 31](#)). This page allows you to set up the system log and to log local functions.

The screenshot shows the Extron System Manager interface for a WAP 100AC Dual Band Wireless Access Point. The left sidebar contains navigation options: Overview, Device Status, Connections, Network, Basic, Wireless, WPS, Management, Advanced, Time Zone, WiFi Scheduler, Tools, System Manager, Account, Firmware, and Log. The main content area is titled 'System Log' and includes the following controls:

- Status:** Radio buttons for 'Enable' (selected) and 'Disable'.
- Log type:** A drop-down menu with 'All' selected. The menu options are: All, Debug, Information, Notice, Warning, Error, Critical, Alert, and Emergency.
- Log Results:** A large empty text box for displaying log entries.
- Buttons:** 'Refresh' and 'Clear' buttons are located to the left of the log results box.
- Remote Log:** Radio buttons for 'Enable' and 'Disable' (selected).
- Log Server IP Address:** A text input field containing '0.0.0.0'.
- Apply:** An 'Apply' button with the text 'Apply saved settings to take effect' below it.

At the bottom left of the page, there is a language dropdown menu set to 'English'.

**Figure 31. System Manager: Log Page**

**Status** — Use the radio buttons to enable or disable the log function.

**Log Type** — Use the drop-down menu to select the type of log.

The results of the log are shown in the text box and can also be saved (see Remote Log, below).

**Refresh** — Updates the information shown in the text box.

**Clear** — Clears the text box.

**Remote Log** — Use the radio buttons to enable or disable the remote log function.

**Log Server IP Address** — Enter the IP address of the server where the log results are stored.

**Apply** — Click **Apply** for the new settings to take effect.

# Building a Wireless Network

The WAP 100AC can operate in one of three modes:

- **Access Point Mode**
- **WDS AP Mode**
- **WDS Bridge Mode**

## Access Point Mode



**Figure 32. Access Point Mode**

In Access Point mode, the WAP 100AC acts as a central connection for stations that support IEEE 802.11ac/a/b/g/n networks. The stations and clients must be configured to use the same SSID (Service Set Identifier) and security password to associate with the WAP 100AC.

**NOTES:**

- The factory configured passwords for all accounts on this device have been set to the device serial number. Passwords are case sensitive.
- If the device is reset to default settings, the passwords are reset to the default password, which is **extron** (for either **admin** or **user**).

The WAP 100AC supports up to eight SSIDs per band (16 total) at the same time for secure access.

## WDS AP Mode

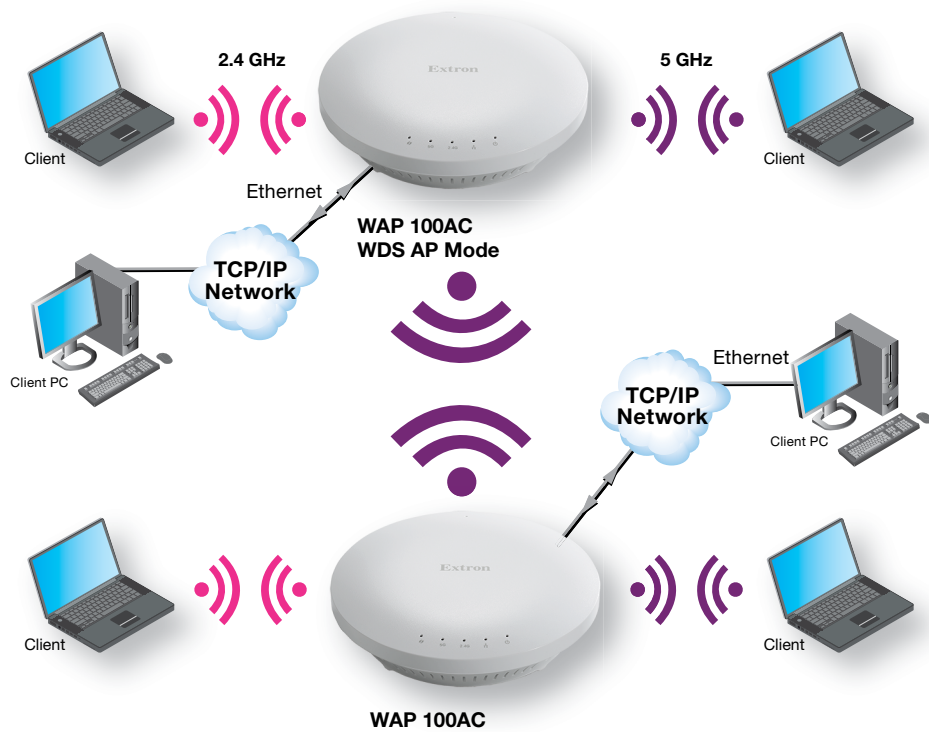
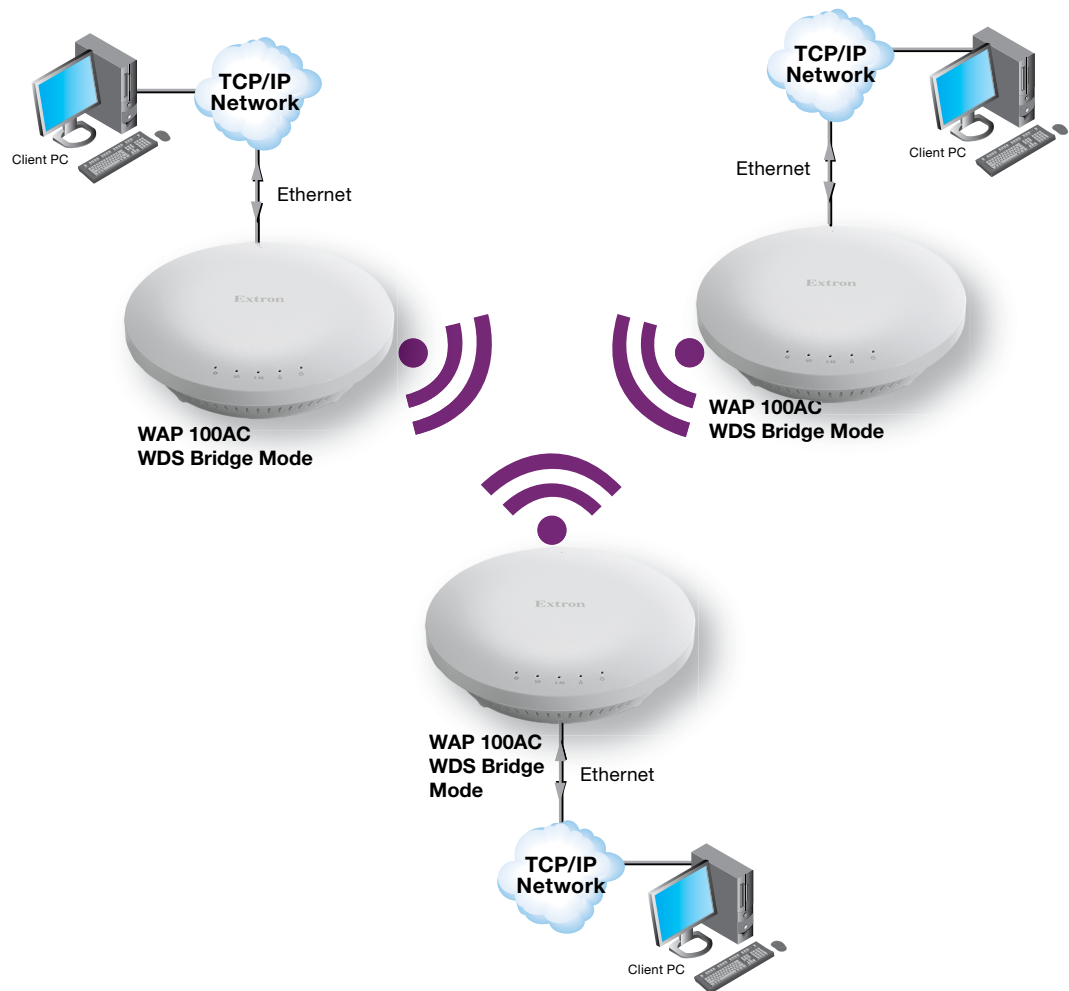

**Figure 33. WDS AP Mode**

In WDS AP (Wireless Distribution System Access Point) mode, allows wireless connections between two WAP 100AC units. This allows the wireless area to be enlarged beyond the area that can be served by a single WAP 100AC unit.

WDS AP supports up to four AP MAC addresses.

## WDS Bridge Mode



**Figure 34. WDS Bridge Mode**

In WDS Bridge mode, the WAP 100AC wirelessly connects different LANs that are a small distance apart and want to communicate with each other. WDS Bridge mode can establish up to four WDS links, creating a star-topology network.

### NOTES:

- All access points in the WDS network must use the same channel and security settings. WDS Bridge mode does not act as an access point because access points linked by WDS use the same frequency channel.
- More access points connected together may lower throughput.
- Multiple WAP 100AC units in this mode can generate endless network loops. Extron recommends that you prevent this by using the **Spanning Tree Protocol (STP) settings** (see page 13).
- Compatibility between different brands and models of access points is not guaranteed. For maximum compatibility, Extron recommends using only WAP 100AC access points to create a WDS network.

# Security Settings

The WAP 100AP has seven security modes:

- [WEP](#)
- [WPA-PSK](#)
- [WPA2-PSK](#)
- [WPA-PSK Mixed](#)
- [WPA-Enterprise](#)
- [WPA2-Enterprise](#)
- [WPA Mixed Enterprise](#)

**NOTE:** Extron strongly recommends using the WPA2-PSK mode.

To configure the security settings:

1. Open the WAP 100AP web pages and log in.
2. Click **wireless** in the Network section of the left side bar (see [Wireless settings](#) on page 14).
3. Scroll down to **SSID profile** (see page 16).
4. Click **Edit** next to the SSID (see [figure 15](#) on page 16).
5. Select the **Security** mode from the drop-down menu.  
The corresponding security configuration page opens.

# WEP

Wired Equivalent Privacy (WEP) is configured as follows:

Wireless Security - 2.4GHz	
Security Mode	WEP
Auth Type	Open System
Input Type	Hex
Key Length	40/64-bit (10 hex digits or 5 ASCII char)
Default Key	1
Key1	
Key2	
Key3	
Key4	
<b>Fast Roaming</b>	
Enable Fast Roaming	<input type="radio"/> Enable <input checked="" type="radio"/> Disable
<b>Wireless MAC Filter</b>	
ACL Mode	Disabled
No.	MAC Address
	<input type="text"/> : <input type="text"/> : <input type="text"/> : <input type="text"/> : <input type="text"/> : <input type="text"/> <input type="button" value="Add"/>
<b>Wireless Traffic Shaping</b>	
Enable Traffic Shaping	<input type="radio"/> Enable <input checked="" type="radio"/> Disable
Download Limit	100 Mbps (1-999)
Upload Limit	100 Mbps (1-999)
<input type="button" value="Save"/> Save current setting(s)	

**Figure 35. WEP Configuration**

- **Auth Type** — Select **Open System** or **Shared Key**.
- **Input Type** — can be **ASCII** or **HEX**
  - **ASCII** — Regular Text (recommended).
  - **HEX** — Hexadecimal numbers (for advanced users).
- **Key Length** — Select **64-bit**, **128-bit**, or **152-bit** password length. Ensure that wireless clients use the same setting.
- **Default Key** — Select the key you wish to be the default. Transmitted data is always encrypted using the default key. The other keys are for decryption only. A key value for the Default Key is required.
- **Keys** — Enter one or more key values that you wish to use. By default, the text box is left empty.

Click **Save** to save the changes.

The following panels are common to all of the security pages. For more information go to:

- **Fast Roaming** (see page 42)
- **Wireless MAC Filter** (see page 42)
- **Wireless Traffic Shaping** (see page 43)

# WPA-PSK

Wi-Fi Protected Access Pre-Shared Key (WPA-PSK) is configured as follows:

The screenshot shows a configuration page for 'Wireless Security - 2.4GHz'. It includes several sections: 'Security Mode' set to 'WPA-PSK', 'Encryption' set to 'Both(TKIP+AES)', an empty 'Passphrase' field, and 'Group Key Update Interval' set to '3600'. The 'Fast Roaming' section has 'Enable Fast Roaming' with 'Disable' selected. The 'Wireless MAC Filter' section has 'ACL Mode' set to 'Disabled' and an empty table for MAC addresses. The 'Wireless Traffic Shaping' section has 'Enable Traffic Shaping' with 'Disable' selected, and both 'Download Limit' and 'Upload Limit' set to '100 Mbps (1-999)'. A 'Save' button is at the bottom left.

**Figure 36. WPA-PSK Configuration**

- **Encryption** — Select the WPA encryption type. Ensure the wireless clients use the same settings.
- **Passphrase** — Wireless clients must use the same key to connect with the device.
  - If using ASCII format, the key must be from 8 to 63 characters in length.
  - If using HEX format, the key must be 64 HEX characters in length.
- **Group Key Update Interval** — Specify how often (in seconds) the Group Key is updated.

Click **Save** to save the changes.

The following panels are common to all of the security pages. For more information go to:

- **Fast Roaming** (see page 42)
- **Wireless MAC Filter** (see page 42)
- **Wireless Traffic Shaping** (see page 43)

## WPA2-PSK

Wi-Fi Protected Access 2 Pre-Shared Key (WPA2-PSK) is configured as follows:

Wireless Security - 2.4GHz	
Security Mode	WPA2-PSK
Encryption	Both(TKIP+AES)
Passphrase	
Group Key Update Interval	3600
<b>Fast Roaming</b>	
Enable Fast Roaming	<input type="radio"/> Enable <input checked="" type="radio"/> Disable
<b>Wireless MAC Filter</b>	
ACL Mode	Disabled
No.	MAC Address
<b>Wireless Traffic Shaping</b>	
Enable Traffic Shaping	<input type="radio"/> Enable <input checked="" type="radio"/> Disable
Download Limit	100 Mbps (1-999)
Upload Limit	100 Mbps (1-999)
<input type="button" value="Save"/> Save current setting(s)	

**Figure 37. WPA2-PSK Configuration**

- **Encryption** — Select the WPA encryption type. Ensure the wireless clients use the same settings.
- **Passphrase** — Wireless clients must use the same key to connect with the device.
  - If using ASCII format, the key must be from 8 to 63 characters in length.
  - If using HEX format, the key must be 64 HEX characters in length.
- **Group Key Update Interval** — Specify how often (in seconds) the Group Key is updated.

Click **Save** to save the changes.

The following panels are common to all of the security pages. For more information go to:

- **Fast Roaming** (see page 42)
- **Wireless MAC Filter** (see page 42)
- **Wireless Traffic Shaping** (see page 43)

## WPA-PSK Mixed

Wi-Fi Protected Access Pre-Shared Key Mixed (WPA-PSK Mixed) is configured as follows:

The screenshot shows the configuration page for 'Wireless Security - 2.4GHz'. The 'Security Mode' is set to 'WPA-PSK Mixed' and 'Encryption' is set to 'Both(TKIP+AES)'. The 'Passphrase' field is empty, and the 'Group Key Update Interval' is set to '3600'. The 'Fast Roaming' section has 'Enable Fast Roaming' with 'Enable' selected. The 'Wireless MAC Filter' section has 'ACL Mode' set to 'Disabled'. The 'Wireless Traffic Shaping' section has 'Enable Traffic Shaping' with 'Disable' selected, and both 'Download Limit' and 'Upload Limit' are set to '100 Mbps (1-999)'. A 'Save' button is at the bottom left.

**Figure 38. WPA-PSK Mixed Configuration**

- **Encryption** — Select the WPA encryption type. Ensure the wireless clients use the same settings.
- **Passphrase** — Wireless clients must use the same key to connect with the device.
  - If using ASCII format, the key must be from 8 to 63 characters in length.
  - If using HEX format, the key must be 64 HEX characters in length.
- **Group Key Update Interval** — Specify how often (in seconds) the Group Key is updated.

Click **Save** to save the changes.

The following panels are common to all of the security pages. For more information go to:

- **Fast Roaming** (see page 42)
- **Wireless MAC Filter** (see page 42)
- **Wireless Traffic Shaping** (see page 43)

# WPA-Enterprise

Wi-Fi Protected Access Enterprise (WPA Enterprise) is configured as follows:

Wireless Security - 2.4GHz	
Security Mode	WPA-Enterprise
Encryption	Both(TKIP+AES)
Group Key Update Interval	3600
Radius Server	
Radius Port	1812
Radius Secret	
Radius Accounting	Disable
Radius Accounting Server	
Radius Accounting Port	1813
Radius Accounting Secret	
Interim Accounting Interval	600
<b>Fast Roaming</b>	
Enable Fast Roaming	<input type="radio"/> Enable <input checked="" type="radio"/> Disable
<b>Wireless MAC Filter</b>	
ACL Mode	Disabled
No.	MAC Address
	<input type="text"/> : <input type="text"/> : <input type="text"/> : <input type="text"/> : <input type="text"/> : <input type="text"/> <input type="button" value="Add"/>
<b>Wireless Traffic Shaping</b>	
Enable Traffic Shaping	<input type="radio"/> Enable <input checked="" type="radio"/> Disable
Download Limit	100 Mbps (1-999)
Upload Limit	100 Mbps (1-999)
<input type="button" value="Save"/> Save current setting(s)	

**Figure 39. WPA Enterprise Configuration**

- **Encryption** — Select the WPA encryption type. Ensure the wireless clients use the same settings.
- **Group Key Update Interval** — Specify how often (in seconds) the Group Key is updated.
- **Radius Server** — Enter the IP address of the Radius server.
- **Radius Port** — Enter the port number used for connections to the Radius server.
- **Radius Secret** — Enter the secret required for connections to the Radius server.
- **Radius Accounting** — Select Enable or Disable for the accounting feature.
- **Radius Accounting Server** — Enter the IP address of the Radius accounting server.
- **Radius Accounting Port** — Enter the port number used for connections to the Radius accounting server.
- **Radius Accounting Secret** — Enter the secret required for connections to the Radius accounting server.
- **Interim Accounting Interval** — Specify how often (in seconds) the accounting data sends.

**NOTE:** 802.11n does not allow WEP/WPA-PSK TKIP/WPA2-PSK TKIP security mode. The connection mode automatically changes from 802.11n to 802.11g.

Click **Save** to save the changes.

The following panels are common to all of the security pages. For more information go to:

- **Fast Roaming** (see page 42)
- **Wireless MAC Filter** (see page 42)
- **Wireless Traffic Shaping** (see page 43)

# WPA2-Enterprise

Wi-Fi Protected Access2 Enterprise (WPA2 Enterprise) is configured as follows:

Wireless Security - 2.4GHz	
Security Mode	WPA2-Enterprise
Encryption	Both(TKIP+AES)
Group Key Update Interval	3600
Radius Server	
Radius Port	1812
Radius Secret	
Radius Accounting	Disable
Radius Accounting Server	
Radius Accounting Port	1813
Radius Accounting Secret	
Interim Accounting Interval	600

**Fast Roaming**

Enable Fast Roaming  Enable  Disable

**Wireless MAC Filter**

ACL Mode: Disabled

No.	MAC Address

**Wireless Traffic Shaping**

Enable Traffic Shaping  Enable  Disable

Download Limit: 100 Mbps (1-999)

Upload Limit: 100 Mbps (1-999)

Save Save current setting(s)

**Figure 40. WPA2 Enterprise Configuration**

- **Encryption** — Select the WPA encryption type. Ensure the wireless clients use the same settings.
- **Group Key Update Interval** — Specify how often (in seconds) the Group Key is updated.
- **Radius Server** — Enter the IP address of the Radius server.
- **Radius Port** — Enter the port number used for connections to the Radius server.
- **Radius Secret** — Enter the secret required for connections to the Radius server.
- **Radius Accounting** — Select Enable or Disable for the accounting feature.
- **Radius Accounting Server** — Enter the IP address of the Radius accounting server.
- **Radius Accounting Port** — Enter the port number used for connections to the Radius accounting server.
- **Radius Accounting Secret** — Enter the secret required for connections to the Radius accounting server.
- **Interim Accounting Interval** — Specify how often (in seconds) the accounting data sends.

**NOTE:** 802.11n does not allow WEP/WPA-PSK TKIP/WPA2-PSK TKIP security mode. The connection mode automatically changes from 802.11n to 802.11g.

Click **Save** to save the changes.

The following panels are common to all of the security pages. For more information go to:

- **Fast Roaming** (see page 42)
- **Wireless MAC Filter** (see page 42)
- **Wireless Traffic Shaping** (see page 43)

## WPA Mixed Enterprise

Wi-Fi Protected Access Mixed Enterprise (WPA Mixed Enterprise) is configured as follows:

Wireless Security - 2.4GHz	
Security Mode	WPA Mixed Enterprise ▾
Encryption	Both(TKIP+AES) ▾
Group Key Update Interval	3600
Radius Server	
Radius Port	1812
Radius Secret	
Radius Accounting	Disable ▾
Radius Accounting Server	
Radius Accounting Port	1813
Radius Accounting Secret	
Interim Accounting Interval	600
<b>Fast Roaming</b> ⓘ	
Enable Fast Roaming	<input type="radio"/> Enable <input checked="" type="radio"/> Disable
<b>Wireless MAC Filter</b>	
ACL Mode	Disabled ▾
No.	MAC Address <input type="text"/> : <input type="text"/> : <input type="text"/> : <input type="text"/> : <input type="text"/> : <input type="text"/> <input type="button" value="Add"/>
<b>Wireless Traffic Shaping</b>	
Enable Traffic Shaping	<input type="radio"/> Enable <input checked="" type="radio"/> Disable
Download Limit	100 Mbps (1-999)
Upload Limit	100 Mbps (1-999)
<input type="button" value="Save"/> Save current setting(s)	

**Figure 41. WPA Mixed Enterprise Configuration**

- **Encryption** — Select the WPA encryption type. Ensure the wireless clients use the same settings.
- **Group Key Update Interval** — Specify how often (in seconds) the Group Key is updated.
- **Radius Server** — Enter the IP address of the Radius server.
- **Radius Port** — Enter the port number used for connections to the Radius server.
- **Radius Secret** — Enter the secret required for connections to the Radius server.
- **Radius Accounting** — Select Enable or Disable for the accounting feature.
- **Radius Accounting Server** — Enter the IP address of the Radius accounting server.
- **Radius Accounting Port** — Enter the port number used for connections to the Radius accounting server.
- **Radius Accounting Secret** — Enter the secret required for connections to the Radius accounting server.
- **Interim Accounting Interval** — Specify how often (in seconds) the accounting data sends.

**NOTE:** 802.11n does not allow WEP/WPA-PSK TKIP/WPA2-PSK TKIP security mode. The connection mode automatically changes from 802.11n to 802.11g.

Click **Save** to save the changes.

The following panels are common to all of the security pages. For more information go to:

- **Fast Roaming** (see page 42)
- **Wireless MAC Filter** (see page 42)
- **Wireless Traffic Shaping** (see page 43)

The following panels are common to all of the security pages:

- **Fast Roaming**
- **Wireless MAC Filter**
- **Wireless Traffic Shaping** (see the next page)

## Fast Roaming

This function ensures that, when mobile client devices roam from access point to access point, they are quickly able to reestablish association with applications.



**Figure 42. Fast Roaming**

To enable **Fast Roaming**, follow these instructions:

1. Enter the SSID settings.
2. Initialize the security mode to WPA-Mixed, WPA2 Enterprise, WPA2-PSK, or WPA-Mixed Enterprise.
3. Configure connections to the Radius Server.
4. Set the same encryption on the other access point.
5. Enable **Fast Roaming**.

Enabling **Fast Roaming** can prevent delays in conversation, when moving between access points while running voice services.

## Wireless MAC Filter

The **Wireless MAC Filter** is used to allow or deny network access to wireless clients based on their MAC addresses. By default, the filter is set to **Disabled**.

When the filter is enabled, you can manually add a MAC address to restrict access to the WAP 100AC.



**Figure 43. Wireless MAC Filter**

- **ACL Mode** — The Access Control List (ACL) Mode determines whether network access is allowed or denied to clients whose MAC addresses are listed in the MAC Address table. The options are:
  - **Disabled** — The ACL mode is not applied and all clients are allowed access to the WAP 100AC
  - **Deny MAC in the list** — Clients in the list are denied access to the WAP 100AC.
  - **Allow MAC in the list** — Only clients listed have access to the WAP 100AC.
- **MAC Address** — Enter the MAC address of the wireless client
- **ACL Mode** — Click **Add** to add that MAC address to the table. Once the address is added, the button next to that address changes to **Delete**.

**Delete** — Click **Delete** to remove the MAC address listed in that row.

**Save** — Click **Save** at the bottom of the page (see [figure 44](#) on the following page) to save the changes.

## Wireless Traffic Shaping

Traffic Shaping regulates the flow of packets leaving an interface to deliver improved quality of service.

Wireless Traffic Shaping	
Enable Traffic Shaping	<input type="radio"/> Enable <input checked="" type="radio"/> Disable
Download Limit	<input type="text" value="100"/> Mbps (1-999)
Upload Limit	<input type="text" value="100"/> Mbps (1-999)
<input type="button" value="Save"/> Save current setting(s)	

**Figure 44. Wireless Traffic Shaping**

- **Enable Traffic Shaping** — Select the appropriate radio button to **Enable** or **Disable** this function.
- **Download Limit** — Specify the wireless transmission speed for downloading.
- **Upload Limit** — Specify the wireless transmission speed for uploading.
- **Save** — Click **Save** to save the changes.

# Mounting

The WAP 100AC can be wall-mounted or ceiling-mounted. This section discusses

- [Before You Start](#)
- [Mounting the WAP 100AC](#)

## Before You Start

Before starting, consider these issues to determine a suitable position to mount the WAP 100AC for optimal performance:

- Mount the WAP 100AC on a wall or ceiling.
- Walls, ceilings, doors, windows, mirrors, and other similar objects weaken the wireless signals. To find the best location, you must take into account the number, thickness, and location of walls and ceilings and keep them to a minimum.
- Brick or metal decrease the strength of wireless signals to a greater extent than dry wall. Objects such as filing cabinets also weaken the signal strength.
- Interference from electrical devices that generate RF noise (for example, microwaves or cordless phones) also weaken the signal.

## Mounting the WAP 100AC

### **ATTENTION:**

- All structural steps and electrical installation must be performed by qualified personnel in accordance with local and national building codes and electrical codes.
- Toute étape structurelle et installation électrique, doit être effectuée par un personnel qualifié, conformément aux codes du bâtiment, aux codes incendie et sécurité, et aux codes électriques, locaux et nationaux.

## Mounting to a Solid Ceiling or Wall

To mount the WAP 100AC to a solid ceiling or wall, Extron provides a mounting bracket (see figure 45, **2**) and a wall mounting hardware kit that includes:

- Two wall plugs (**1**)
- Two P3.5x32 screws (**3**)
- Two P2.6x12 screws (**4**)

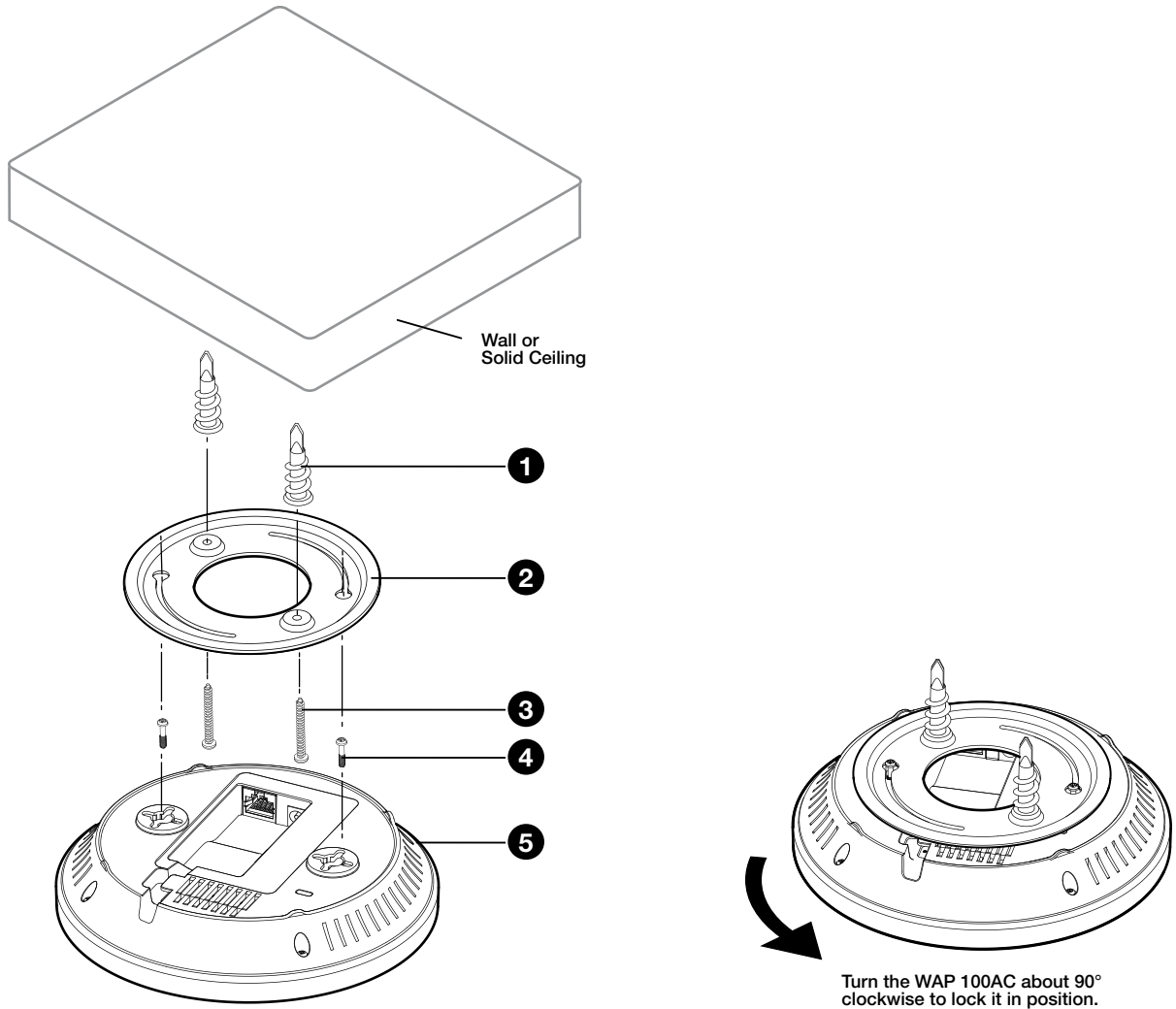

**Figure 45. Mounting the WAP 100AC to a Solid Ceiling or Wall**

To mount the unit, follow these instructions:

- 1.** Drill two pilot holes 2.76 inches (70 mm) apart.
- 2.** Screw in the wall plugs until they are flush with the ceiling or wall.
- 3.** Attach the mounting bracket, using the P3.5x32 screws.
- 4.** Insert the P2.6x12 screws into the mounting holes on the top of the WAP 100AC (**5**). Leave enough of the screws exposed to insert them into the mounting bracket.

If you need extra space between the WAP 100AC and the mounting bracket, use the spacers and long screws from the T-rail mounting kit (see [Mounting to a Dropped Ceiling](#) on the following page).

5. Connect the cables. The WAP 100AC can use a 12 VDC desktop power supply or a PoE injector. Extron recommends using PoE.

**ATTENTION:**

- Do not connect either power supply before reading the **Attention** on page 6.
  - Ne branchez pas de sources d'alimentation externes avant d'avoir lu les **mises en garde** page 6.
  - Disconnect power from either power supply before making any connections.
  - Débranchez de sources d'alimentation externes avant d'effectuer n'importe quelles connexions.
- If you are using PoE, connect the LAN cable only (see **figure 2, A** on page 4).
  - If you are using a 12 VDC desktop power supply, connect the power supply cable (see **figure 2, B**).
6. Insert the heads of the P2.6\*12 screws (see **step 4** on the previous page) into the holes in the mounting bracket.
  7. Turn the WAP 100AC about 90° clockwise to lock it into place.
  8. Power on the PoE injector or 12 VDC power supply.
    - The power LED lights (orange).
    - The WLAN LEDs light (blue for 2.4G and green for 5G)
    - The LAN connection LED lights (blue)

You are now ready to configure the WAP 100AC (see **Internal Web Pages** on page 8).

## Mounting to a Dropped Ceiling

To mount the WAP 100AC to a dropped ceiling, Extron provides a mounting hardware kit that includes:

- Two P2.6\*10 screws (see figure 46, **1**)
- Two P2.6\*25 screws (**2**)
- Two 9/16 inch (1.43 cm) T-rail connectors (**3**)
- Two 15/16 inch (2.38 cm) T-rail connectors (not shown)
- Two spacers (**4**)

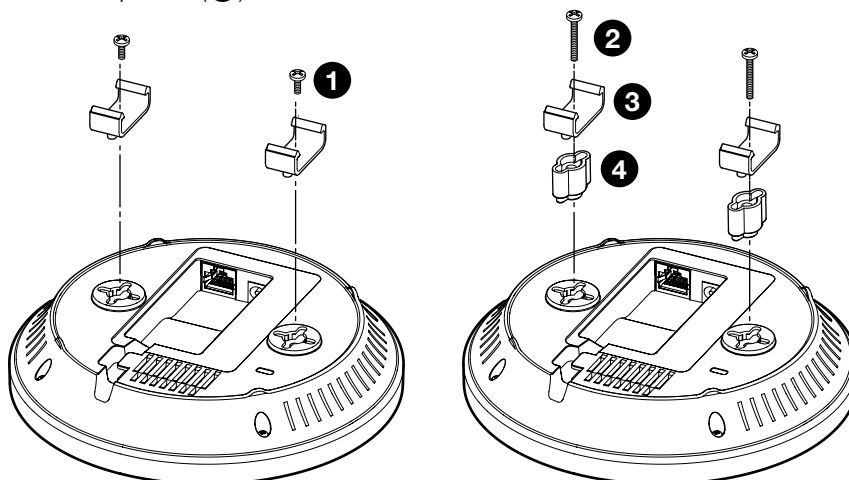

**Figure 46. Preparing the WAP 100AC to Mount in a Dropped Ceiling**

To mount the unit, follow these instructions:

1. Decide whether you need the 9/16 inch or 15/16 inch T-rail connectors and whether you need to use the spacers to accommodate ceiling tiles.  
If you do not need the spacer, use the shorter (P2.6\*10) screws. If you require the spacers, use the longer (P2.6\*25) screws.

2. Connect the cables. The WAP 100AC can use a 12 VDC desktop power supply or a PoE injector. Extron recommends using PoE.

**ATTENTION:**

- Do not connect either power supply before reading the **Attention** on page 6.
- Ne branchez pas de sources d'alimentation externes avant d'avoir lu les **mises en garde** page 6.
- Disconnect power from either power supply before making any connections.
- Débranchez de sources d'alimentation externes avant d'effectuer n'importe quelles connexions.

- If you are using PoE, connect the LAN cable only (see **figure 2, A** on page 4).
- If you are using a 12 VDC desktop power supply, connect the power supply cable (see **figure 2, B**).

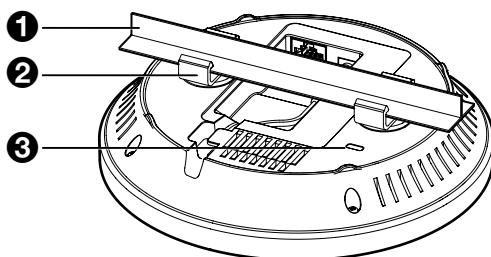

**Figure 47. Attaching the WAP 100AC to T-Rail**

3. Align the T-rail connectors with the T-rail and press the unit until the connectors snap into place.
4. Power on the PoE injector or 12 VDC power supply.
  - The power LED lights (orange).
  - The WLAN LEDs light (blue for 2.4G and green for 5G)
  - The LAN connection LED lights (blue)

You are now ready to configure the WAP 100AC (see **Internal Web Pages** on page 8).

## Kensington Security Lock

For added security, once the installation is complete, attach a Kensington Security Lock (not provided) to the metal-reinforced slot on the top of the unit (see **figure 2, E** on page 4).

Follow the instructions that are provided by the manufacturer to install the lock.

# Extron Warranty

Extron warrants this product against defects in materials and workmanship for a period of three years from the date of purchase. In the event of malfunction during the warranty period attributable directly to faulty workmanship and/or materials, Extron will, at its option, repair or replace said products or components, to whatever extent it shall deem necessary to restore said product to proper operating condition, provided that it is returned within the warranty period, with proof of purchase and description of malfunction to:

**USA, Canada, South America, and Central America:**

Extron  
1230 South Lewis Street  
Anaheim, CA 92805  
U.S.A.

**Asia:**

Extron Asia Pte. Ltd.  
135 Joo Seng Road, #04-01  
PM Industrial Bldg.  
Singapore 368363  
Singapore

**Japan:**

Extron, Japan  
Kyodo Building, 16 Ichibancho  
Chiyoda-ku, Tokyo 102-0082  
Japan

**Europe:**

Extron Europe  
Hanzeboulevard 10  
3825 PH Amersfoort  
The Netherlands

**China:**

Extron China  
686 Ronghua Road  
Songjiang District  
Shanghai 201611  
China

**Middle East:**

Extron Middle East  
Dubai Airport Free Zone  
F13, PO Box 293666  
Dubai, United Arab Emirates

**Africa:**

Extron South Africa  
South Tower  
160 Jan Smuts Avenue  
Rosebank 2196, South Africa

This Limited Warranty does not apply if the fault has been caused by misuse, improper handling care, electrical or mechanical abuse, abnormal operating conditions, or if modifications were made to the product that were not authorized by Extron.

**NOTE:** If a product is defective, please call Extron and ask for an Application Engineer to receive an RA (Return Authorization) number. This will begin the repair process.

**USA:** 714.491.1500 or 800.633.9876

**Asia:** 65.6383.4400

**Europe:** 31.33.453.4040 or 800.3987.6673

**Japan:** 81.3.3511.7655

**Africa:** 27.11.447.6162

**Middle East:** 971.4.299.1800

Units must be returned insured, with shipping charges prepaid. If not insured, you assume the risk of loss or damage during shipment. Returned units must include the serial number and a description of the problem, as well as the name of the person to contact in case there are any questions.

Extron makes no further warranties either expressed or implied with respect to the product and its quality, performance, merchantability, or fitness for any particular use. In no event will Extron be liable for direct, indirect, or consequential damages resulting from any defect in this product even if Extron has been advised of such damage.

Please note that laws vary from state to state and country to country, and that some provisions of this warranty may not apply to you.